

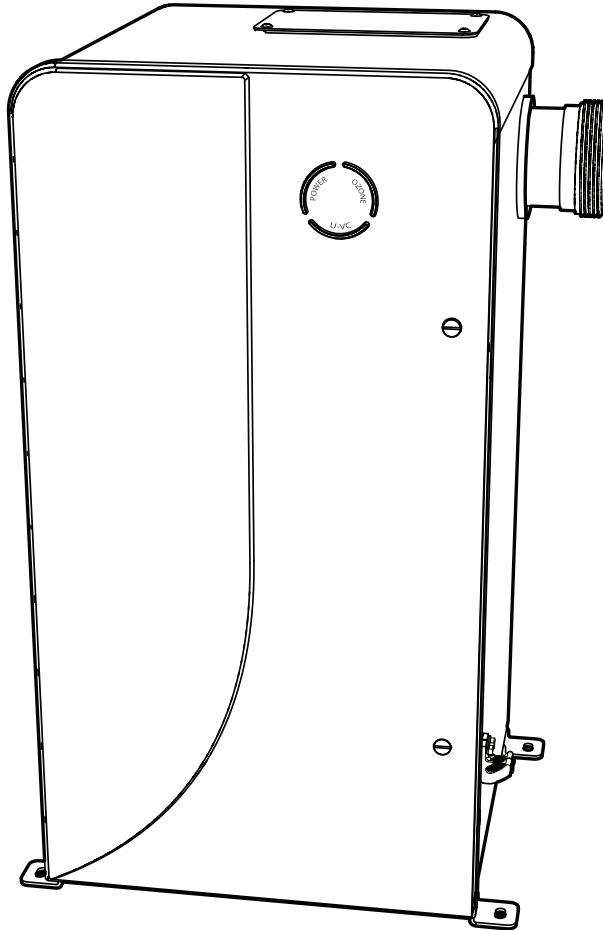

Installation and Operation Manual
Manuel d'installation et d'utilisation
Manual de instalación y operación



Jandy X Series™ AOP System

JAOPX200
JAOPX350

WARNING

FOR YOUR SAFETY – This product must be installed and serviced by a contractor who is licensed and qualified in pool equipment by the jurisdiction in which the product will be installed where such state or local requirements exist. The maintainer must be a professional with sufficient experience in pool equipment installation and maintenance so that all of the instructions in this manual can be followed exactly. Before installing this product, read and follow all warning notices and instructions that accompany this product. Failure to follow warning notices and instructions may result in property damage, personal injury, or death. Improper installation and/or operation may void the warranty.



Improper installation and/or operation can create unwanted electrical hazard which may cause serious injury, property damage, or death.

ATTENTION INSTALLER – This manual contains important information about the installation, operation and safe use of this product. This information should be given to the owner/operator of this equipment.

Table of Contents

Section 1. Important Safety Instructions.....	3	5.7 Flow Switch.....	18
Section 2. System Information	4	5.8 Orifice Plate.....	19
2.1 Jandy X Series AOP System Overview	4	5.9 Circuit Board	20
2.2 Specifications.....	4	5.10 Ballast.....	21
Section 3. Installation	5	Section 6. Troubleshooting & FAQ.....	22
3.1 Tools.....	5	6.1 System Status Indicator Troubleshooting	22
3.2 Location	5	6.2 System Troubleshooting.....	23
3.3 Mounting	6	6.3 Frequently Asked Questions	23
3.4 Plumbing	6	Section 7. Appendices.....	24
3.5 Electrical.....	9	7.1 Appendix A: Jandy AOP X Series Installation - System Plumbing	24
Section 4. Operation.....	10	7.2 Appendix B: Jandy AOP Pressure Drop.....	25
4.1 Pool Preparation.....	10	7.3 Appendix C: Optional In-Place Quartz Tube Cleaning	26
4.2 Initial System Start-Up	10		
4.3 Status LED Indicators	11		
4.4 System Shutdown	11		
4.5 Winterizing.....	11		
Section 5. Maintenance & Service.....	12		
5.1 System Electromechanical Overview.....	12		
5.2 Technical Contact Information	13		
5.3 Ordering Information:	13		
5.4 Standard Replacement Parts List	14		
5.5 Ozone System Maintenance	14		
5.6 UV System Maintenance.....	16		

EQUIPMENT INFORMATION RECORD	
DATE OF INSTALLATION	_____
INSTALLER INFORMATION	_____
NOTES	_____

Section 1. Important Safety Instructions

READ AND FOLLOW ALL INSTRUCTIONS

WARNING

- Read this manual completely before attempting installation. Failure to install in accordance with the installation instructions may void warranty and result in injury or death.
- All permanent electrical connections should be made by a qualified electrician.
- A pressure wire connector, labeled "bonding lugs", is provided on the outside of the unit to permit connection to a minimum No. 6 AWG (13.3 mm²) solid bonding conductor between this point and any metal equipment, metal enclosures of electrical equipment, metal water pipes, or conduit within 5 feet (1.5 meters) of the unit as needed to comply with local requirements. In Canada, at least two lugs marked "BONDING LUGS" are provided on the external surface.
- All field-installed metal components such as rails, ladders, drains, or other similar hardware within 5 feet (1.5 meters), 10 feet (3 meters) in Canada, of the pool, spa, or hot tub shall be bonded to the equipment grounding bus with copper conductors not smaller than No. 8 AWG In the U.S., and No. 6 AWG in Canada.
- Install at least 5 feet (1.5 meters) from wall of pool or spa. In Canada, install at least 10 feet (3 meters) from the wall of pool or spa. Install in accordance with the installation instructions.
- Follow all applicable local, state, and federal electrical and building codes.
- Short-term inhalation of high concentrations of ozone and long term inhalation of low concentrations of ozone can cause serious harmful physiological effects. DO NOT inhale ozone gas produced by this device.
- To reduce the risk of injury, do not permit children to use this product.
- If unit is not operated according to instructions, high dosages of harmful substances may potentially be released.
- Children should not use spas or hot tubs without adult supervision.
- Do not use pool, spa, or hot tubs unless all suction guards are installed to prevent body and hair entrapment.
- People using medications and/or having an adverse medical history should consult a physician before using a spa or hot tub.
- People with infectious diseases should not use a spa or hot tub.
- To avoid injury, exercise care when entering or exiting pool, spa, or hot tub.
- Do not use drugs or alcohol before or during the use of a pool, spa, or hot tub to avoid unconsciousness and possible drowning.
- Pregnant or possibly pregnant women should consult a physician before using a spa or hot tub.
- Water temperature in excess of 38°C can be injurious to your health.
- Before entering the spa or hot tub, measure the water temperature with an accurate thermometer.
- Do not use a spa or hot tub immediately following strenuous exercise.
- Do not permit electric appliances (Such as a light, telephone, radio, or television) within 5 feet (1.5 M) of the pool, spa, or hot tub.
- Maintain water chemistry in accordance with manufacturer's instructions.

HYPERTHERMIA

Hyperthermia occurs when the internal temperature of the body reaches a level several degrees above the normal body temperature of 37 °C. The symptoms of hyperthermia include drowsiness, lethargy, and an increase in the internal temperature of the body. The effects of hyperthermia include

- unawareness of impending hazard;
- failure to perceive heat;
- failure to recognize the need to exit spa;
- physical inability to exit spa;
- fetal damage in pregnant women; and
- unconsciousness and danger of drowning.

THE USE OF ALCOHOL OR DRUGS CAN GREATLY INCREASE THE RISK OF FATAL HYPERTHERMIA IN HOT TUBS AND SPAS.

DANGER

ELECTRIC SHOCK HAZARD: Be sure to turn power OFF and disconnect from power source before any service work is performed. Failure to do so could result in serious injury or death.

The AOP must be installed in an outdoor location, or indoors in a forced air ventilated room, and installed so that the orientation is exactly as shown in following instructions. Install to provide water drainage of generator to protect electrical components.

Mount the AOP so that it is inaccessible to anyone in the pool. Never attempt any servicing while unit is wet.

For your safety, do not store or use gasoline, chemicals or other flammable liquids or vapors near this or any other appliance.

NOTICE

To maintain cosmetic integrity, protect this unit from direct prolonged sunlight exposure.

ENVIRONMENTAL NOTICE: Hg-Lamp CONTAINS MERCURY. Manage in accordance with disposal laws. See: www.lamprecycle.org

WARNING

Some vinyl pool liners with particular through-wall fittings may be incompatible with ozone. These fittings may cause fading of the vinyl liner, cover or other vinyl components where the ozone returns to the pool. Zodiac Pool Systems LLC is not liable for fading of vinyl-lined pools.

SAVE THESE INSTRUCTIONS

Section 2. System Information

2.1 Jandy X Series AOP System Overview

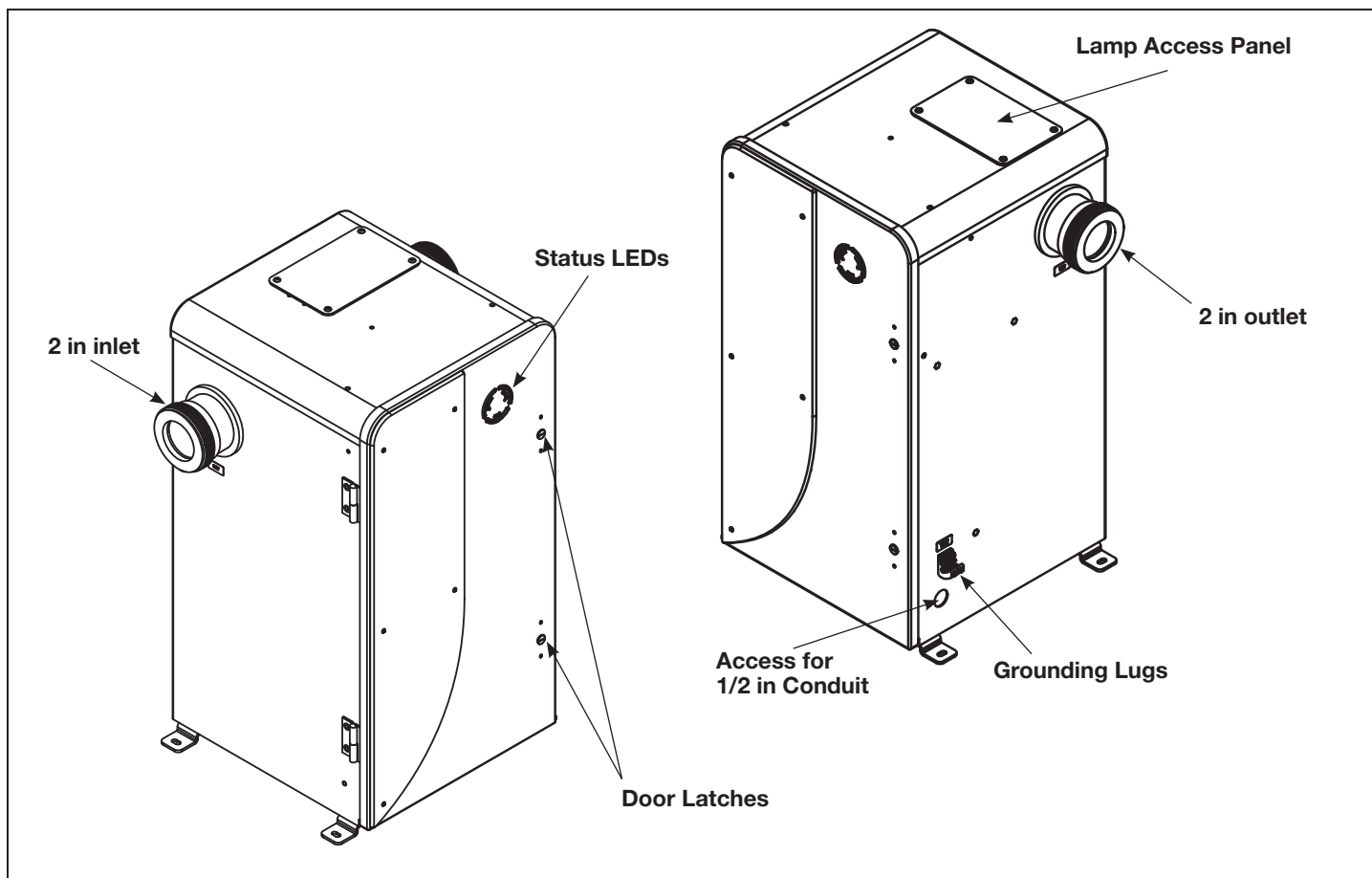

Figure 1. Jandy AOP System Exterior Overview

The Jandy AOP System (Figure 1) is designed to provide the benefits of ozonated and UV treated water in an environmentally safe and effective manner. The system is certified to NSF 50 as a supplemental sanitizer and tested for effectiveness to kill active microbes and bacteria. Operated according to the instructions, the Jandy AOP virtually eliminates the unpleasant effects of traditional chemicals. Jandy AOP products are safe and harmless to your equipment when installed properly.

2.2 Specifications

2.2.1 Power Requirements

- 120V/ 240V
- 60 Hz / 50 Hz
- JAOPX200: 0.9 Amps, JAOPX350: 1.1 Amps

2.2.2 Weights

- Shipping Weight: 55 lbs / 25 kg
- Dry Weight: 50 lbs / 23 kg
- Wet Weight: 64 lbs / 29 kg

2.2.3 Location Requirements

- Mounting: Ground or Wall mounted
- Ambient Recommended Temperature: 30°F - 120°F (0°C - 50°C)

⚠ CAUTION

Water Level: Additional system back pressure created in certain applications or by certain accessories may impact the system's ability to pull vacuum properly. (Example: equipment below water level, in-floor cleaning system, etc.) This can result in water pushing back into the ozone gas line and possibly into the ozone cell(s). Please consult Customer Support if conditions exist that may introduce higher than normal back pressures (>3 psi).

2.2.4 Recommended Flow Rates

System	Minimum Flow	NSF Tested Max Flow	Max Flow Rate
JAOPX200	20 GPM	30 GPM	80 GPM
JAOPX350	20 GPM	40 GPM	80 GPM

- The unit must meet the minimum flow rate to activate the internal flow switch. Below this flow rate the system will not turn on.
- The NSF Tested max flow is the rate at which a 3-log disinfection rate is achieved to meet the supplemental sanitizer requirements.
- Operation above the NSF tested max flow rates decreases the Jandy AOP system effectiveness. At higher flow rates, there will also be higher levels of undissolved ozone in the return lines; the optional MDV can be installed to remove excess ozone from the system.

2.2.5 NSF Testing

This product is designed for supplemental disinfection when operated according to these instructions, and should be used with registered or approved disinfection chemicals to impart residual concentrations. Supplemental Disinfection – NSF/ANSI 50, section 13.19 disinfection efficacy testing for 3-log (99.9%) or greater of *Enterococcus faecium* [ATCC #6569] and *Pseudomonas aeruginosa* [ATCC #27313]. Specific residual levels of EPA registered disinfecting chemicals may be required by the regulatory agency having authority.

Section 3. Installation

3.1 Tools

- Cordless drill
- Masonry drill bit, anchors or other appropriate fasteners
- Wrench

3.2 Location

3.2.1 Environment

Locate the unit in a clean, protected area, either indoors or outdoors (preferably out of direct sunlight). If possible, locate the unit out of reach of sprinklers or drainage spouts.

3.2.2 Clearance

Allow sufficient access for maintenance (2 ft clearance above and 1 ft on either side of the unit) and all plumbing and electrical hookups. Front clearance for door swing is approximately 14 inches.

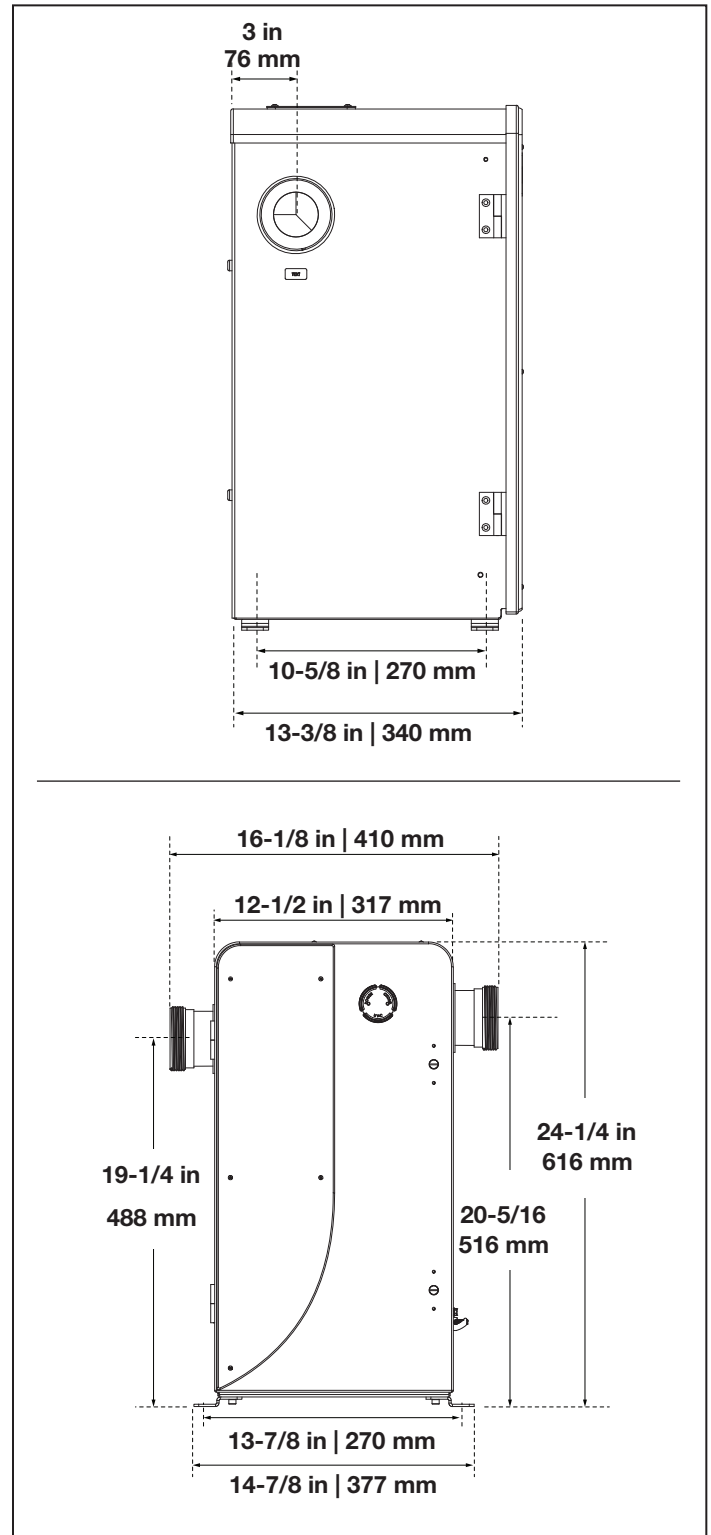

Figure 2. JAOPX200 and JAOPX350 Installation Related Dimensions

3.3 Mounting

3.3.1 Ground Mounting

The Jandy AOP is shipped with the mounting brackets installed in the ground mounting position.

Adjust the position of the bracket if necessary and tighten the screws.

Mount the unit to the equipment pad through the slots provided on bracket using appropriate hardware for the mounting surface.

3.3.2 Wall Mounting

Four ¼"-20 screw holes are located on the back of enclosure for wall mounting as shown in Figure 3.

1. Remove plastic screws from back of the unit.
2. Remove mounting brackets from bottom of enclosure, re-assemble them to back of enclosure.
3. Mount unit to wall through the slots on brackets using appropriate hardware for the mounting surface.

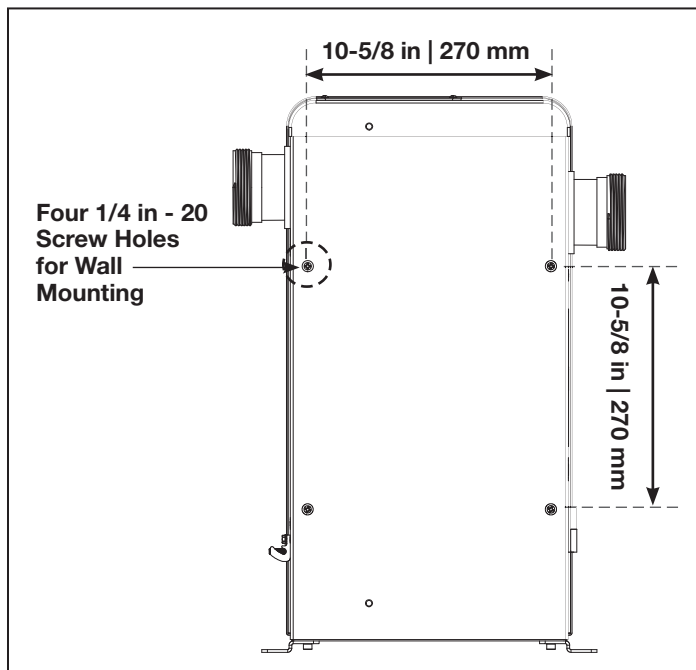

Figure 3. Wall Mounting Hole Pattern

3.4 Plumbing

The Jandy AOP can easily be added into the pool plumbing loop. All system components are inside the enclosure. Only the water inlet and outlet need to be installed into the pool return line.

3.4.1 Plumbing Location

- Install in the pool main return line after all other pool equipment (pump, filter, heater, and cleaner).
- The outlet must be at least 10 feet from the first return to the pool. If installing a mixing de-gas vessel (MDV Inline), allow 10 feet from the outlet of the MDV Inline to the first pool return.
- Use the union fittings provided to connect the Jandy AOP inlet and outlet to pool plumbing as shown in Figure 4.
- For installation with additional sanitizers and pool cleaners, see section 7.1 *Appendix A: Jandy X Series AOP Installation - System Plumbing*. Figure 2 shows related dimensions. Figure 4 shows a typical plumbing diagram.

3.4.2 About the Mixing De-Gas Vessel (optional)

Under normal operation, bubbles will appear in the return flow to the pool. To remove the bubbles from the flow, an accessory Mixing De-Gas Vessel, or MDV, can be installed downstream of the Jandy AOP. The MDV Inline is designed for use with the Jandy AOP and is recommended on indoor, covered, or vinyl-lined pools. For more information, please contact Technical Support.

NOTE: An MDV Inline may be recommended to reduce the chance of minor fading of the vinyl at the pool's ozone return fitting.

Some vinyl pool liners with particular through-wall fittings may be incompatible with ozone. These fittings may cause fading of the vinyl liner, cover or other vinyl components where the ozone returns to the pool. **Zodiac Pool Systems LLC is not liable for fading of vinyl-lined pools.**

3.4.3 Above Water Level Installation: Water Backflow Check Valve

If the pool equipment is mounted above the water line, install a 2 inch hydroseal check valve (25830-400-000) between the pump outlet and the inlet of Jandy AOP to prevent the pump from draining and losing prime when not in use.

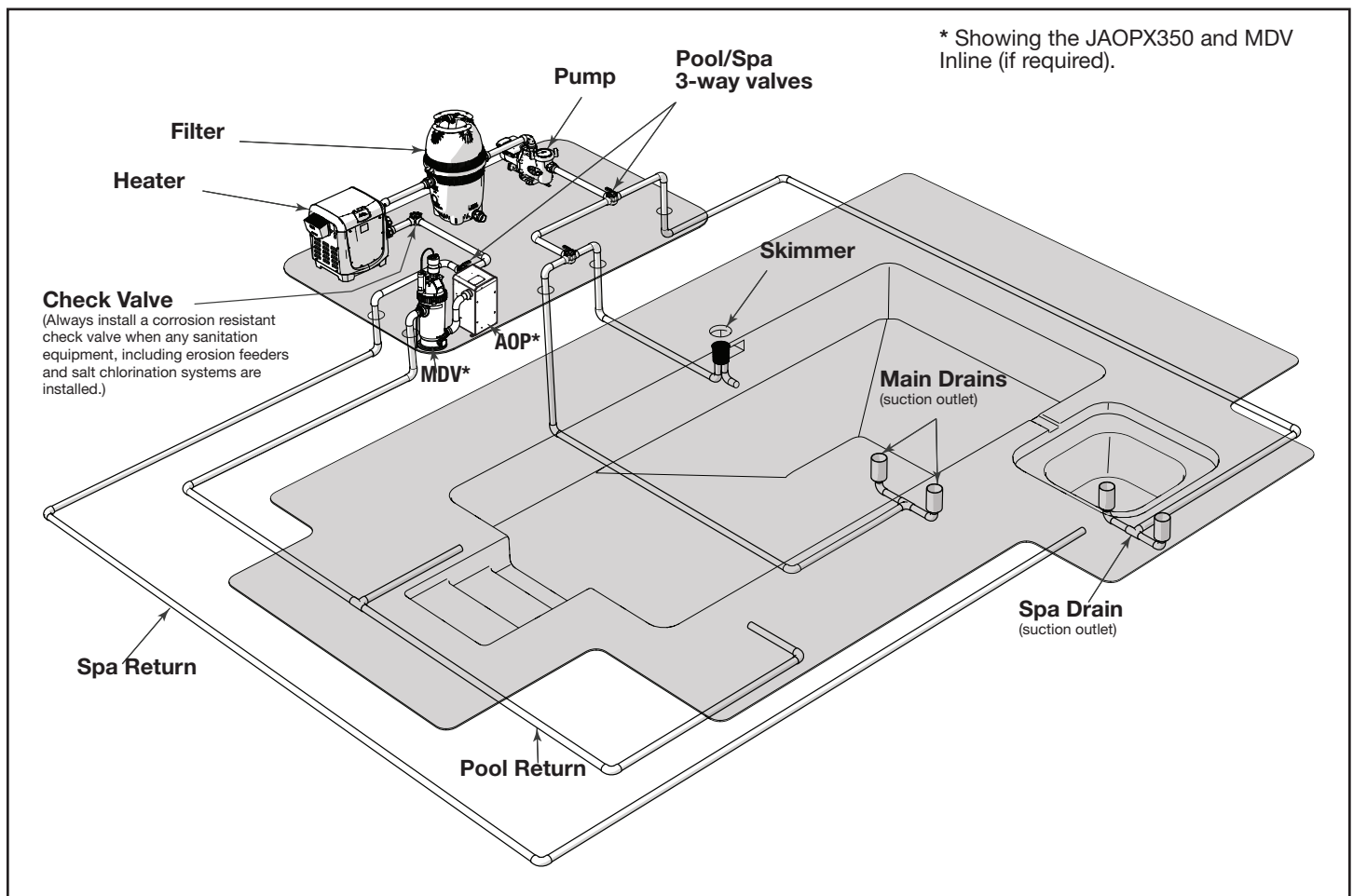

Figure 4. Typical Jandy AOP Location in Pool Plumbing Loop

3.4.4 Pressure Test

If a pressure test is required, it should be performed prior to installing the check valve assembly tubing connections. See Figure 6.

1. Shut off power at the breaker.
2. Shut off water to the unit.
3. Use a flat blade screwdriver to turn the door latches counter clockwise and open the door.
4. Loosen or remove the tubing clamp on the injector tube adapter end of the ozone gas line. Use pliers (if necessary) to twist and unlock the clamp.
5. Pull the tubing from injector tube adapter, then unthread the adapter from the injector manifold.
6. Apply Teflon™ based thread sealant and install the injector cap into the injector manifold.
7. Turn on pool circulation system and run at highest normal operating pressure.
8. Check for leaks outside and inside of the Jandy AOP system. Correct any leaks outside of the system. Contact Customer Service for any internal leaks.
9. Once the pressure test is complete, turn off the pool circulation system.
10. Remove the injector cap and clean off any existing Teflon based thread sealant and add new. Re-thread the injector tube adapter into the injector manifold.
11. Push the free end of the tubing into the injector tube adapter.
12. Secure the tubing clamp on the injector tube adapter end of the ozone gas line. Use pliers (if necessary) to twist and lock the clamp.
13. Use a flat blade screwdriver to turn the door latches counter clockwise and close the door.
14. Turn on water and power at their sources.

3.4.5 Flow Test

NOTE: The JAOPX200 includes the flow meter assembly and orifice plate. They are supplied to assist with the system operating with a slower flow requirement. Use the orifice plate to improve the injector manifold suction if the testing results in inadequate flow which affects the system's proper operation. See Figures 5 and 6.

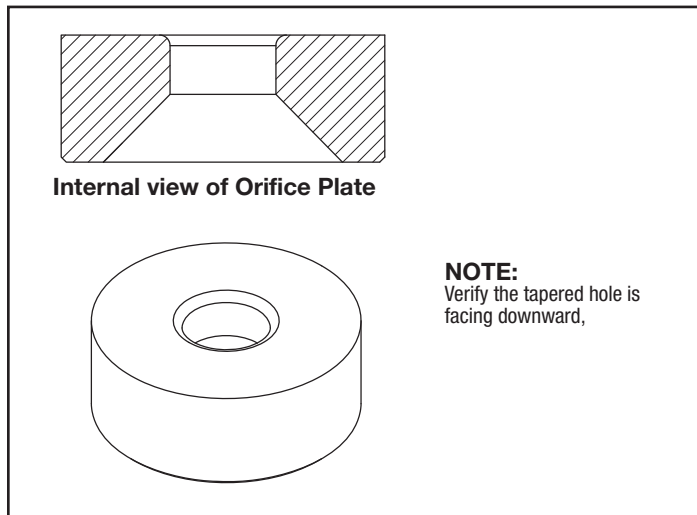

Figure 5. Orifice Plate Proper Orientation

1. Temporarily disconnect tubing from inlet side of the check valve and attach included flow meter assembly. See Figure 6.
2. Hold the flow meter assembly so that the clear plastic chamber is vertical and pointed down.
3. Turn on the pool pump as this allows the injector to pull a vacuum. Under normal operation, the ball in the flow meter assembly will be floating between the min and max lines. At a minimum, the ball should indicate at least a small amount of air flow. If you experience complications, see *Troubleshooting* section.

NOTE: For the JAOPX200 only: If the flow meter ball does not move (indicating too little flow), install the Orifice Plate into the Injector Manifold's check valve with the tapered hole facing downward and retest for flow improvement.

4. After the system flow has been verified, remove the flow meter assembly and reconnect the tubing to the inlet side of the check valve. Secure all tube connections on the check valve assembly with tube clamps.

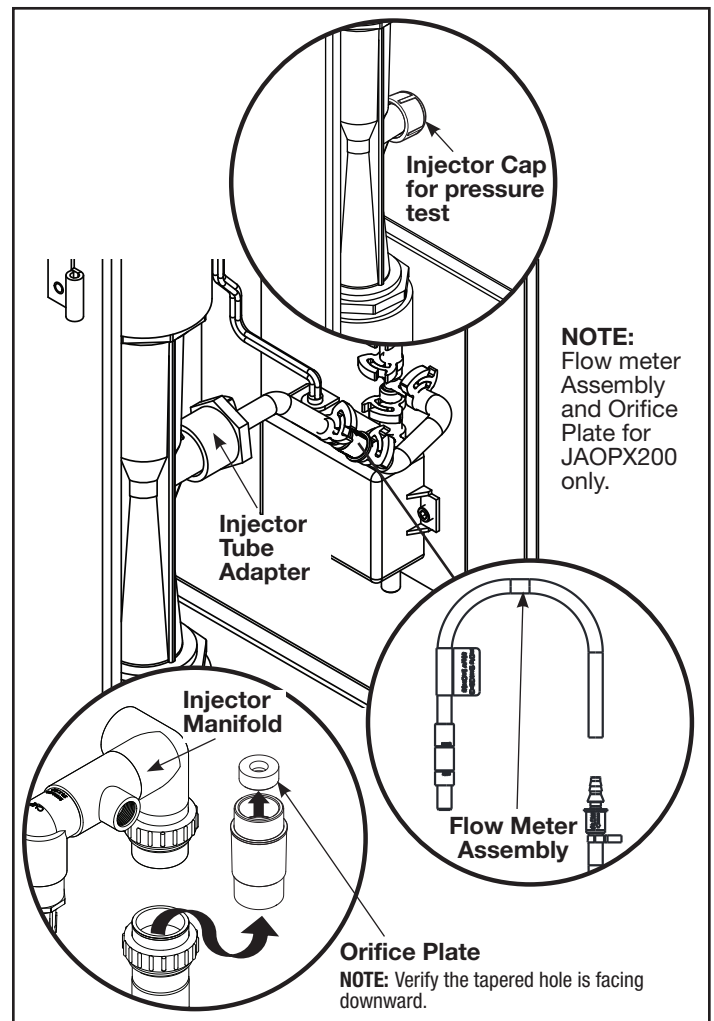

Figure 6. Jandy AOP Flow and Pressure Testing

3.5 Electrical

3.5.1 Main Power

- Connect to the pool timing clock so that the Jandy AOP operates simultaneously with the pool pump.
- An access hole is provided for a 1/2" conduit fitting. Install fitting (not provided) and run wire to terminal block inside unit.
- Connect Line 1, Line 2 or Neutral, and Ground to the terminal block as indicated by the label on the electrical panel located on the inner right side of enclosure. See Figure 7.
- If there is no timing clock or automation system available, the system can be installed on the line voltage along with the variable speed pump.

Refer to the IMPORTANT SAFETY INSTRUCTIONS at the beginning of this manual for important wiring information.

3.5.2 Bonding and Grounding

⚠ CAUTION

This AOP system must be connected to a bonding grid with a solid copper wire not smaller in diameter than 8 AWG (In Canada, it shall be no smaller than 6 AWG.)

The National Electrical Code® (NEC® in the United States) or the Canadian Electrical Code (CEC in Canada) requires pool equipment to be bonded to each other. Check your local codes to determine if the NEC or CEC and/or other local installation codes are enforced by the Authority Having Jurisdiction (AHJ in the United States) or the local competent authorities in Canada. A solid, copper 8.37 mm² (8 AWG) wire is required per the NEC, and 13.3 mm² (6AWG) per the CEC, for bonding the equipment to a permanent bonding connection that is acceptable to the local AHJ or the local competent authorities in Canada.

Refer to your locally enforced codes for the acceptable bonding wire gauge. Connect to the bonding point located on the bottom of the AOP system to a common bonding point. Do not use the AOP system as the common bonding point. Each piece of non-related pool equipment requiring a ground should also be bonded to the common, approved bonding point.

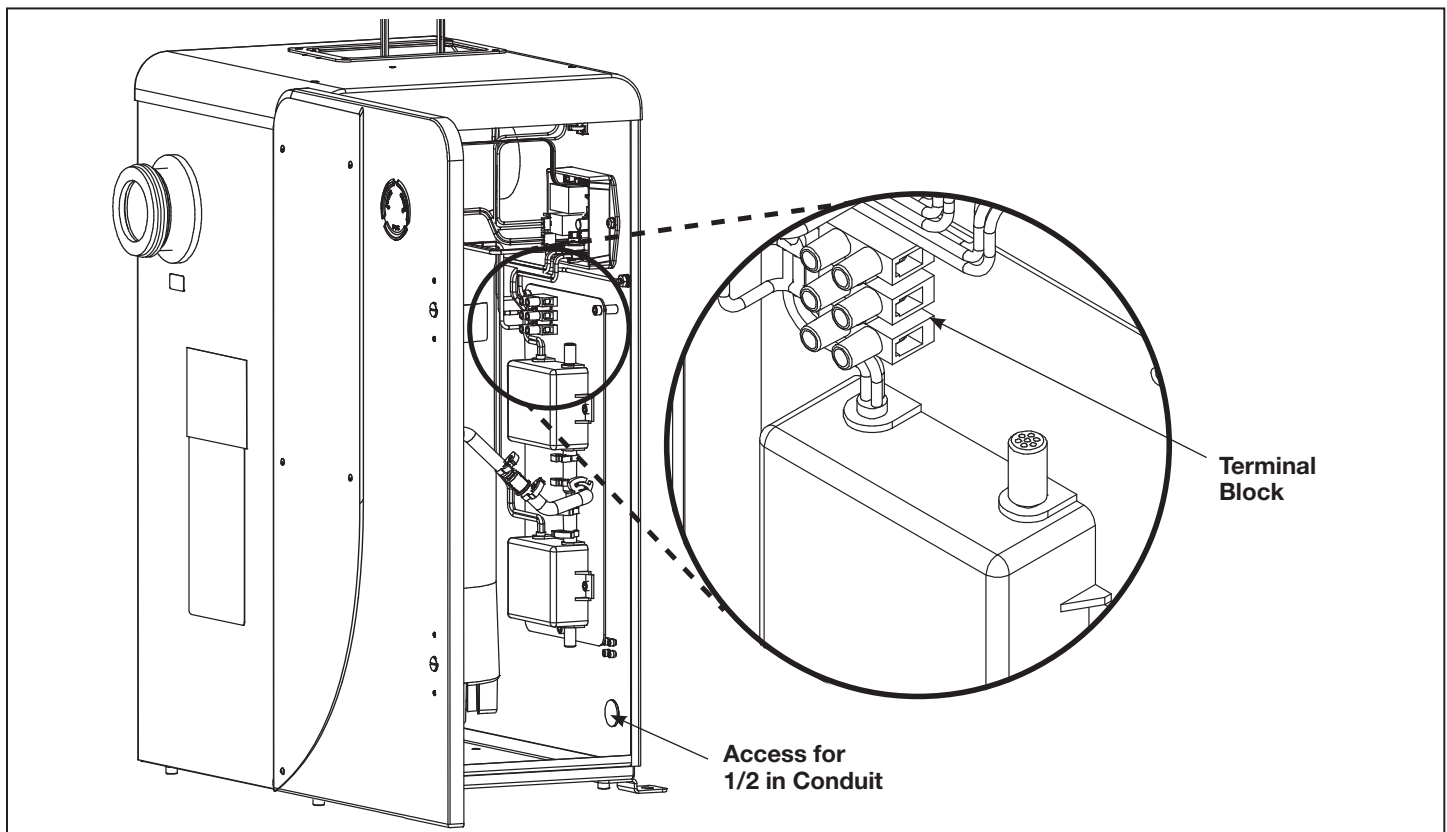

Figure 7. Terminal Block and Wiring Instructions

National Electrical Code® (NEC®) requires bonding of the Pool Water. Where none of the bonded pool equipment, structures, or parts are in direct connection with the pool water; the pool water shall be in direct contact with an approved corrosion-resistant conductive surface that exposes not less than 5800 mm² (9 in²) of the surface area to the pool water at all times. The conductive surface shall be located where it is not exposed to physical damage or dislodgement during usual pool activities, and it shall be bonded in accordance with the bonding requirements of NEC Article 680. Refer to locally enforced codes for any additional pool and spa bonding requirements.

Section 4. Operation

4.1 Pool Preparation

To achieve optimal performance the pool must be as clean as possible to start with.

1. Backwash or clean filters one day before starting the Jandy AOP System.
2. Raise chlorine level to APSP recommended levels so the water has a sustained 1-3 ppm free chlorine level.
3. Test pool chemistry and adjust pH between 7.4 and 7.6. Adjust total alkalinity between 80 and 120 ppm.
4. Run pool filtration continuously for 24 hours prior to starting the Jandy AOP system.

4.2 Initial System Start-Up

Upon completing all of the system connections and cleaning the pool as outlined in Sections 3.4 *Plumbing*, 3.5 *Electrical*, and 4.1 *Pool Preparation*, you are ready to start the Jandy AOP.

1. Check electrical connections at breaker box.
2. Turn on pool circulation system and the Status LEDs will turn on automatically.

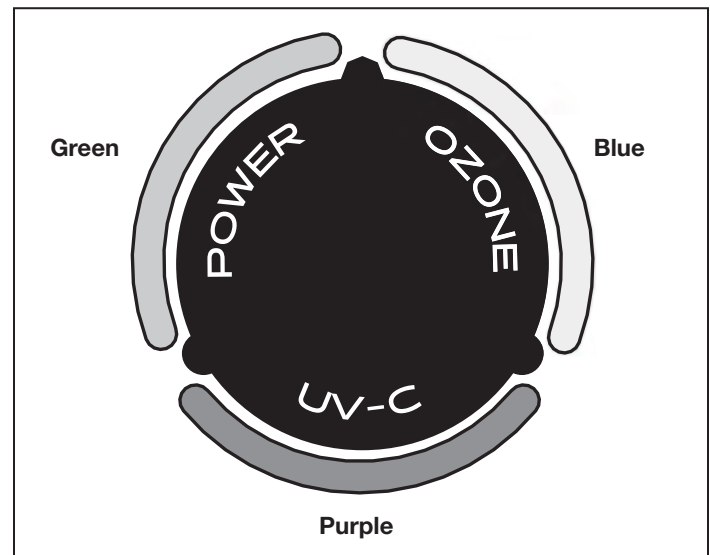

Figure 8. Status LED Indications at Normal Operation

4.3 Status LED Indicators

The Jandy AOP has indicator lights (Figure 8) to indicate its working condition. The lights should display the correct colors after the pump has reached steady flow (see section 2.2.4 *Recommended Flow Rates*). During normal operation, refer to Table 1 below for status information.

Indicator lights have improved over time. Refer to troubleshooting decal on right side of cabinet to confirm working condition of specific Jandy AOP system. For more detailed status information, refer to *Section 6 Troubleshooting & FAQ*.

Table 1. Jandy AOP Statuses at Normal Operation

Status	Power Indicator	UV-C Indicator	Ozone Indicator
Regular Operation	Green	Purple	Blue
Ozone Service Due	Green	Purple	Yellow
UV-C Service Due	Green	Yellow	Blue
Ozone Error/Fault	Green	Purple	Red
UV-C Error/Fault	Green	Red	Blue
Ozone Service Overdue	Green	Purple	Blinking Red
UV-C Service Overdue	Green	Blinking Red	Blue
System Error/Fault	Red	Off	Off

4.4 System Shutdown

The following sequence of steps must be followed for servicing or for storage.

1. Shut off power at the breaker.
2. Shut off water to the unit.

4.5 Winterizing

If the pool will be shutting down for the winter months and the Jandy AOP will remain exposed to freezing temperatures, the unit must be drained to prevent freeze damage. Follow the steps below to drain.

1. If mounted below the water level, bypass valves must all be CLOSED to prevent excess water from draining through the unit.
2. Open the enclosure door.
3. Locate the 1" NPT drain plug and remove to drain the remaining water. See Figure 9.
4. Water will drain through holes in the bottom of the unit. Alternatively a connection can be made at the 1" NPT drain to run water away from the unit.

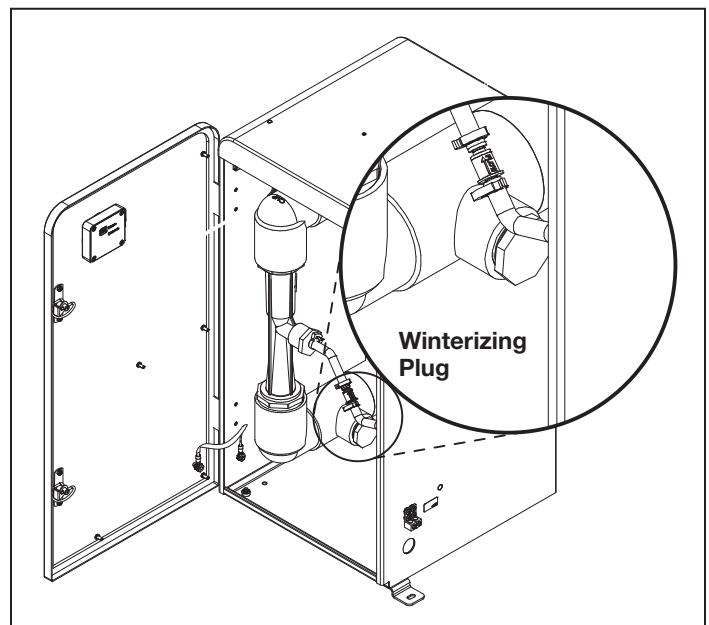

Figure 9. Winterization Plug Location

5. Allow all the water to drain before threading the plug back into the plumbing. Be sure to clean any excess water that may have collected in the bottom of the unit.

Section 5. Maintenance & Service

5.1 System Electromechanical Overview

⚠ CAUTION

Disconnect power before performing service. Refer to the IMPORTANT SAFETY INSTRUCTIONS displayed in the front of this manual.

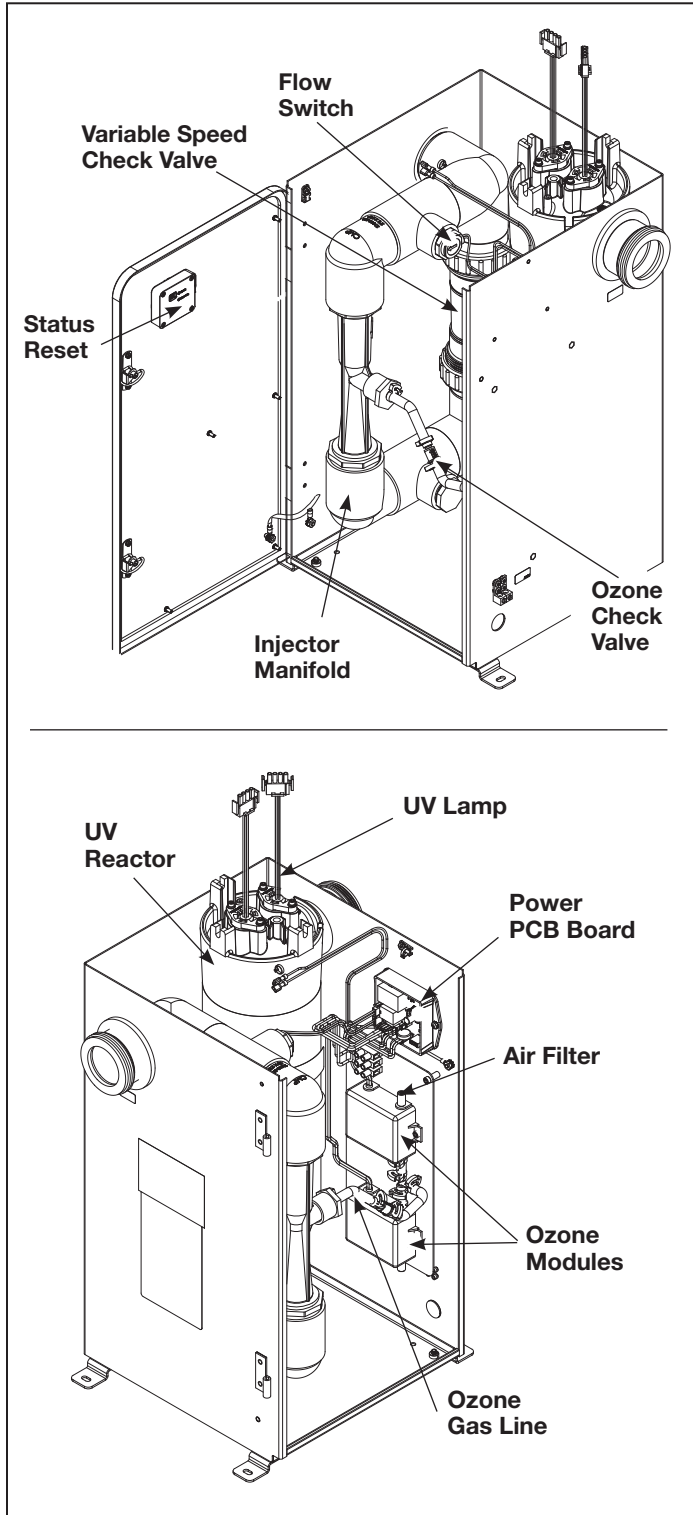

Figure 10. Jandy AOP Electro-Mechanical Overview (JAOPX350 Shown)

5.1.1 Ozone Module Description

The Jandy AOP is constructed with one (JAOPX200) or two (JAOPX350) corona discharge ozone modules. Blue ozone light on system Status LEDs indicate ozone modules are operating properly (refer to Figure 11 Orthographic View for a more detailed view).

5.1.2 Injector Manifold Description

Water flowing through the injector manifold generates the vacuum that draws ozone into the water. The spring-loaded valve automatically adjusts for various water flow rates to keep the Jandy AOP operating over a wide range of conditions.

5.1.3 Ozone Gas Line Description

Gas from the ozone modules is drawn through the ozone gas line by the injector and into the water. The ozone check valve (refer to Figure 12 Angle View) in this line prevents water from migrating back to the ozone modules when the Jandy AOP is not running.

5.1.4 Ozone Module Air Filter Description

The air entering the ozone modules passes through the air filter (refer to Figure 11 Orthographic View) on each module inlet. The filter is held in place by the rubber filter cap.

5.1.5 Injector Tube Adapter Description

This component connects the ozone gas line to the injector manifold (refer to Figure 12 Angle View). When servicing this component, do not tighten past 10 in-lbs torque or the component may be damaged.

5.1.6 Ultraviolet Lamps Description

There are two lamps in each Jandy AOP unit. The purple UV-C light on system Status LEDs indicates UV lamps are operating properly (see Figure 8). If the UV lamp access panel is removed while the unit is running, the unit will be shut down automatically (see Figure 14). The lamps are each housed in a quartz tube that protects the lamp.

5.1.7 Power PCB Assembly Description

The Power PCB Assembly provides power to the sub-assemblies and receives inputs from sensors or switches within the JAOPX200 / JAOPX350 system. There are four main systems connected to this Power PCB Assembly:

- Panel Switch
- Flow Switch
- Input Power from Terminal Block (Ground, Line 1 and Line 2 connections) for the power cable assembly

- Ozone Module 1
- Ozone Module 2 (JAOPX350 ONLY)
- Ballast Connectors

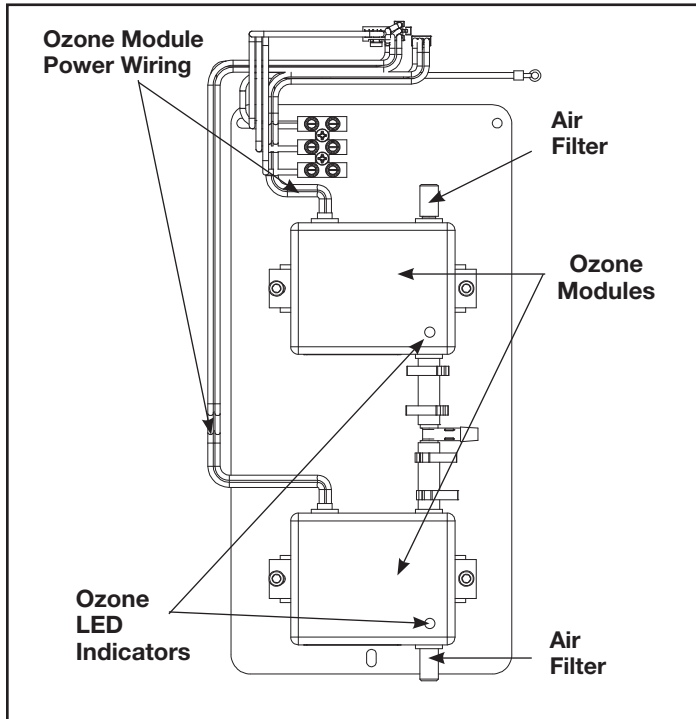

Figure 11. Ozone Generator System Overview Orthographic View

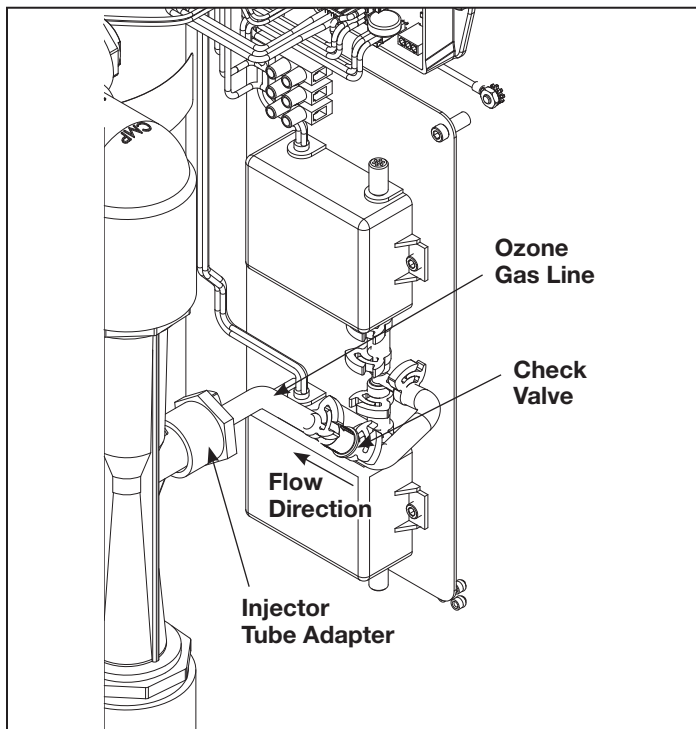

Figure 12. Ozone Generator System Overview Angle View

5.2 Technical Contact Information

For technical assistance, contact our Technical Support Department at 800.822.7933.

Be prepared with the following information:

- Name
- Address
- Model #
- Date Purchased

5.3 Ordering Information:

For a complete list of replacement parts, please visit jandy.com, call Jandy Technical Support at 800.822.7933, or email productsupport@fluidra.com.

5.4 Standard Replacement Parts List

Description	JAOPX200	JAOPX350
Replacement UV Lamp	R0991800 (Two Per Unit)	
Ozone Module with Air Filter	R0997800 (One Per Unit) (One Air Filter included in R-Kit)	R0997800 (Two Per Unit) (One Air Filter included in R-Kit)
Ozone Gas Line (includes Ozone Check Valve with Tubing)	R0991000	
Injector Tube Adapter	R0991100 (One included in R0991000 R-Kit)	
Flow Switch	R0991200	
Orifice Plate (JAOPX200)	R0991300	
Unionized Check Valve	R0991400	
Circuit Boards	R1015200	
Quartz Tube	R0991900	
Ballast	R0991700	
Air Filter	R1091700 (Three Air Filters included in R-Kit)	

NOTE: The warranty may be voided if the parts listed above are not replaced at recommended intervals.

5.5 Ozone System Maintenance

5.5.1 Ozone Module Replacement

- Ozone module life expectancy is about 12,000 hours. All ozone modules should be replaced at the same time.
- The Status LED for Ozone will change to yellow when it is time to replace the ozone module(s).
NOTE: Blinking red indicates it is overdue.
- There is also an LED indicator on the ozone module itself. However, even if the ozone module light(s) are glowing, the module should be replaced when the ozone status indicates it is time to change. The ozone module may be producing little or no ozone after this period of time.

To replace the Ozone Module:

- Shut off power at the breaker.
- Use a flat blade screwdriver to turn the door latches counter clockwise and open the door.
- Disconnect the ozone module by tracing the ozone module power wiring back to the nearest connector and by unlatching hook tab on connector. See Figure 12.
- Remove the old ozone module from ozone generator mounting panel using an Allen wrench.

- Disconnect air filter and tubing from the old ozone module.
- Reconnect the connector of new ozone module to the mating connector previously described in step 3.
- Turn power ON at the breaker.
- Reset ozone indicator by pressing the Reset Ozone button on the inside door behind the status LED indicators. See Figure 13 Reset Ozone Button inset.
- Close the door and turn the door latches to secure once the system is operational.

5.5.2 Ozone Gas Line Replacement

Replace the ozone gas line every year or sooner, if needed. If there is evidence of water leaking past the ozone check valve toward the ozone modules, shut down the Jandy AOP immediately and replace the ozone gas line.

- Verify that power and water remain OFF.
- Loosen the tubing clamps on both ends of the ozone gas line. Remove the tubing assembly from the air barbs of injector tube adapter and the ozone output barb on the ozone module (used on model JAOPX200) or the T-fitting adapter (only used in model JAOPX350). See Figure 13 air barb inset.

3. Orient ozone gas line as shown in Figure 13 (note flow direction callout), ensuring the gas flows towards the injector manifold. Re-connect onto the air barbs of the injector tube adapter and the ozone output barb on the ozone module (used on model JAOPX200) or the T-fitting adapter (only used in model JAOPX350). Use pliers to secure all clamps previously removed or loosened.
4. Turn power and water ON at their sources.
5. Close the door and turn the door latches to secure once the system is operational.

⚠ WARNING

Trace amounts of nitric acid may be present in the ozone gas line. Wear proper safety equipment (gloves and eye protection) and avoid direct contact with any condensation in the line.

5.5.3 Ozone Air Filter Replacement

Air filter should be replaced yearly.

1. Disconnect air filter from the ozone module.
2. Install new air filter to the ozone module.

5.5.4 Injector Tube Adapter Replacement

NOTE: Replace if worn or damaged.

1. Shut off power at the breaker.
2. Shut off water to the unit.
3. Use a flat blade screwdriver to turn the door latches counter clockwise and open the door.
4. Loosen or remove the tubing clamp. Use pliers (if necessary) to twist and unlock the clamp.
5. Pull the tubing from injector tube adapter, then unthread the adapter from the injector manifold. See Figure 13 injector tube adapter inset.
6. Apply Teflon™ based thread sealant and thread the new injector tube adapter into the Injector Manifold.

NOTE: Do not tighten over 10 in*lb.

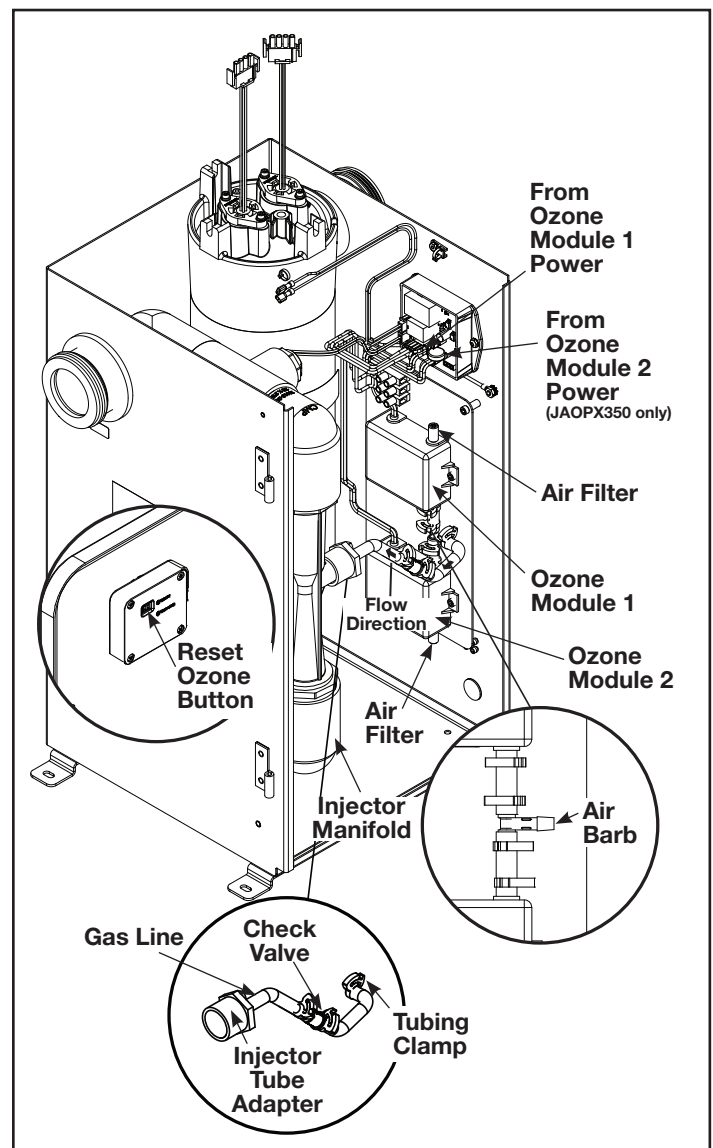

Figure 13. JAOPX200 / JAOPX350 Ozone Modules

5.6 UV System Maintenance

5.6.1 UV Lamp Replacement

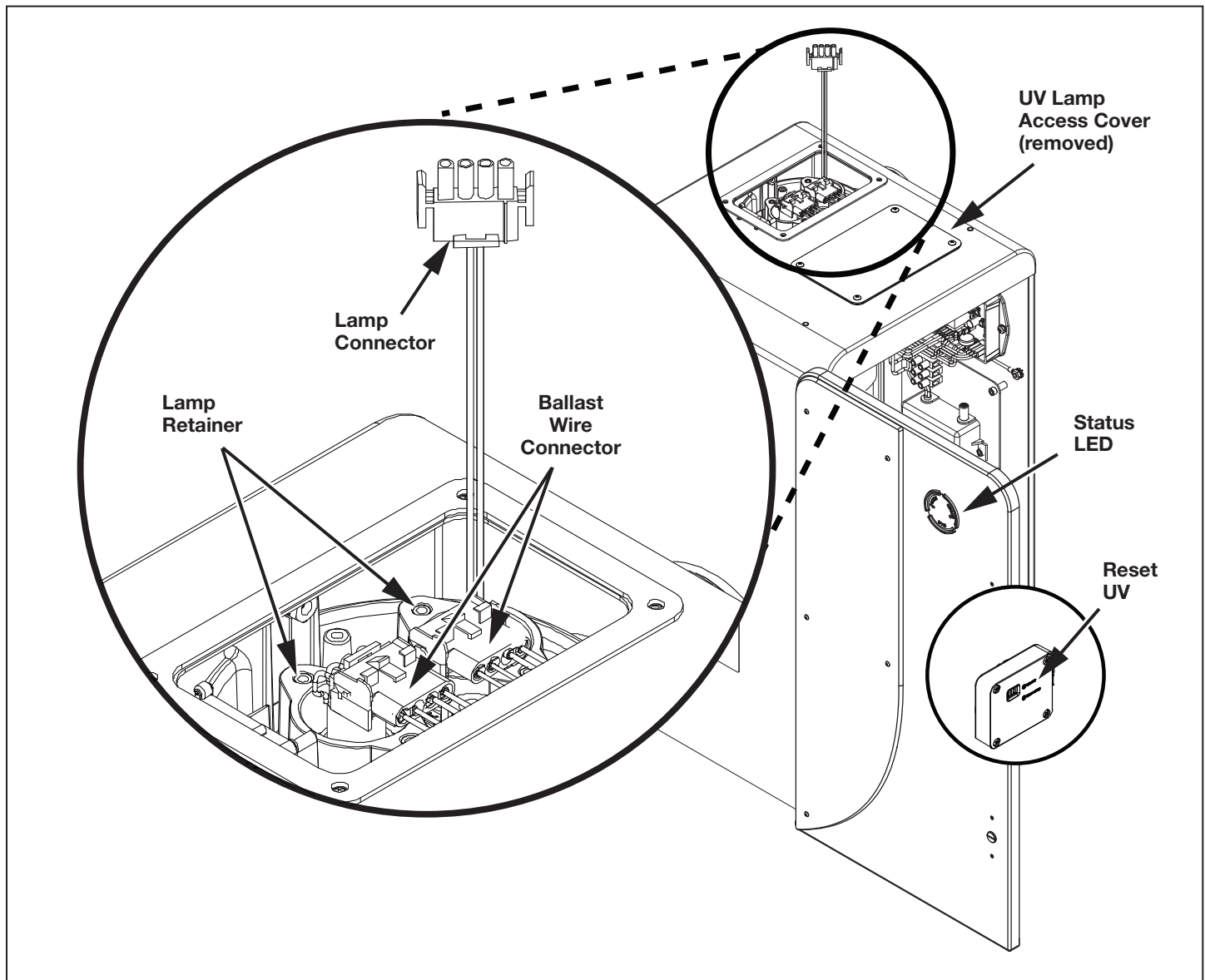

Figure 14. UV Lamp Replacement

- Life expectancy of UV lamp is about 16,000 hours.
- The Status LED for UV-C will change to yellow when it is time to replace the lamps. It is recommended to replace all UV lamps at the same time.

NOTE: Blinking red indicates it is overdue.

- **AVOID TOUCHING THE UV LAMP GLASS WITH YOUR BARE HANDS.** Oils on your hands can cause hot spots on the UV lamp and shorten its life. Use a soft clean cotton cloth or clean cotton gloves to handle the UV lamp.

To remove the UV lamp from UV reactor:

1. Shut off power at the breaker.
2. Use a Phillips-head screwdriver to remove the four (4) screws holding the access cover. See Figure 14.
3. Before continuing, allow adequate time for the lamp to cool.
4. Disconnect the lamp connectors from the ballast wire connectors. Then grasp the UV lamp wires and gently pull until the top of the UV lamp has pulled past the lamp retainer tabs. See Figure 14.

- While holding the UV lamp white ceramic cap, slowly pull the UV lamp until the bottom has pulled past the lamp retainer tabs. Twisting the lamp may help facilitate removal. Set aside and dispose per local disposal guidelines.

To re-install the UV lamp:

NOTE: Do not touch glass, as oils on your hands will damage the UV lamp.

- Carefully insert the new UV lamp into the UV lamp retainer slot until the top ceramic cap is past the retainer tabs.
- Reconnect the connector of new UV lamp to the ballast wire connectors.
- Turn power ON at the breaker.
- Reset UV-C indicator by pressing the Reset UV button on the inside door behind the Status indicators. See Figure 14 inset.
- Secure the UV lamp access panel using the four (4) screws once the system is operational.

5.6.2 Quartz Tube Removal and Cleaning (Every Six Months)

The UV lamps are housed in a quartz tube. If the quartz tube becomes dirty, its ability to transmit UV rays from the lamp will be diminished. The quartz tube(s) should be removed from the UV reactor every six (6) months and cleaned if necessary.

NOTE: For instructions on cleaning without mechanical disassembly, see section 7.3 *Appendix C: Optional In-Place Quartz Tube Cleaning*.

NOTE: If the Jandy AOP is installed below water level, the bypass valves must all be CLOSED to prevent excess pool water from draining into the open unit when a quartz tube is removed.

- Shut off power at the breaker.
- Locate the UV lamp access panel on the top of the Jandy AOP. Remove the four (4) screws with a Phillips head screwdriver, and remove the panel. See Figure 14.
- Before continuing, allow adequate time for the quartz tubes to cool. Drain the water from the UV reactor by removing the drain plug. Replace the plug once water has stopped exiting the UV reactor. See Figure 15.

- Grasp the UV lamp wires and gently pull until the top of the UV lamp has pulled past the lamp retainer tabs. See Figure 15.

- While holding the UV lamp white ceramic cap, slowly pull the UV lamp until the bottom has pulled past the lamp retainer tabs. (Twisting the lamp may help facilitate removal.)

NOTE: Do not touch glass, as oils on your hands will damage the UV lamp.

- After removing the lamps, remove the top lamp retainer screws using the hex key included in the parts bag. Place the lamp retainer screws, washers and the lamp retainer aside in a safe place. See Figure 15.
- Grasp the quartz tube from the top of the UV reactor. Pull to remove it from the UV reactor. See Figure 15.
- Remove the sealing O-ring from the top of the quartz tube. Set aside in a safe place. See Figure 15.
- Clean the quartz tube exterior with a mild solution of muriatic acid (available at all pool supply stores) and water in a ratio of four parts water to one part acid (4:1). If lime or hard water calcium deposits are encountered, use a household tub and shower lime remover.
- After cleaning the quartz tube, wash it off and wipe dry. Inspect the quartz tube for cracks. Replace if cracks are found. Make sure the inside of the quartz tube is dry before replacing the UV lamp(s).

CAUTION

Follow the directions for use and handling of muriatic acid on the acid bottle label, being careful to protect your eyes. Wear rubber gloves, and avoid breathing acid fumes.

NOTE: DO NOT USE ABRASIVE CLEANERS as they can scratch the high quality quartz glass.

NOTE: DAMAGE CAUSED BY BROKEN QUARTZ TUBES ARE NOT COVERED UNDER YOUR LIMITED WARRANTY.

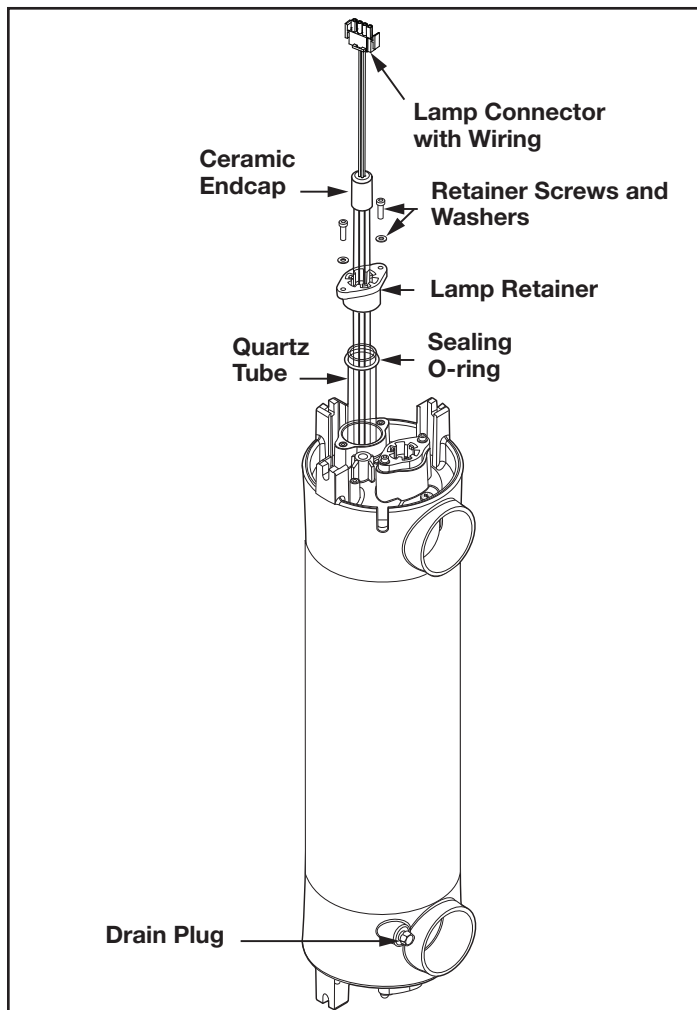

Figure 15. UV Reactor Subassembly

5.6.3 Quartz Tube Installation

1. Hold the quartz tube so it is oriented straight up and down. Insert the quartz tube into the UV reactor until it is fully seated in the bottom of the UV reactor. See Figure 16.

NOTE: If the end of the quartz tube is protruding from the UV reactor, the alignment is off. Remove and re-insert the quartz tube to seat it properly.

2. Place a sealing o-ring approximately 1/2in (12.5mm) from the end of the quartz tube protruding from the top of the UV reactor.
3. Place the lamp retainer over the quartz tube. Use the hex key included in the parts bag to attach the lamp retainer to the UV reactor, using the lamp retainer screws and washers. Torque lamp retainer screws to 15 in/lbs. Make sure the lamp retainer flanges are fully seated against the UV reactor. See Figure 16.

4. Turn the circulation pump ON and check the quartz tube seal for leaks.
5. Turn the circulation pump OFF once you have confirmed that the quartz tube is not leaking.

⚠ CAUTION
Wear proper eye and skin protection for servicing glass components. If broken glass is trapped in the pool system, do not operate the pool. Contact a service professional to have the glass removed.

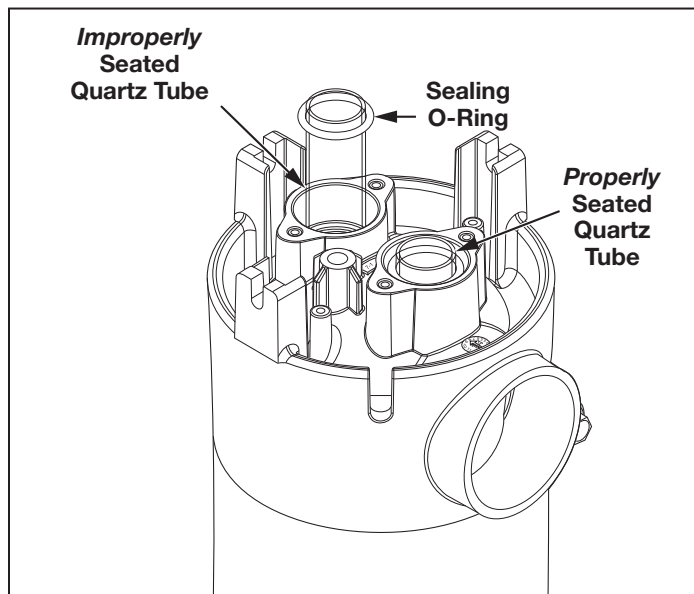

Figure 16. UV Quartz Tube Installation

5.7 Flow Switch

The Jandy AOP system must meet the minimum flow rate to activate the internal flow switch. Below this flow rate, the system will not turn on.

The flow switch assembly can be found on the injector manifold assembly gas and water flow plumbing line in a T-connector.

1. Shut off power at the breaker.
2. Shut off water to the unit.
3. Use a flat blade screwdriver to turn the door latches counter clockwise and open the door.
4. Disconnect the flow switch connectors from the circuit board assembly. See Figure 17.
5. Unscrew the flow switch from the T-connector pipe housing.
6. Carefully remove from its seat.

7. Apply Teflon™ based thread sealant on the new flow switch and replace by screwing into pipe housing seat. Do NOT over-tighten.

NOTE: Ensure flow switch is oriented such that the flow indication arrow is pointing toward the enclosure door.

8. Reconnect the flow switch into the appropriate slot on the circuit board assembly. See Figure 17.
9. Turn water and power ON at their sources and test the flow switch is operating correctly and that no leak is present.
10. Close the door and turn the door latches to secure once the system is operational.

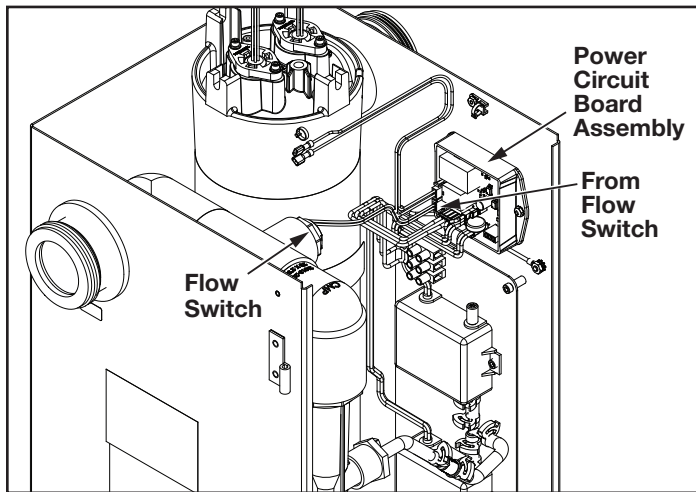

Figure 17. JAOPX200 / JAOPX350 Flow Switch Location and Electrical Connection

5.8 Orifice Plate

The orifice plate is found in the entry of the variable speed check valve connected to the water inlet plumbing flow. It is used with the JAOPX200 to improve the injector manifold's suction.

1. Shut off power at the breaker.
2. Shut off water to the unit.
3. Use a flat blade screwdriver to turn the door latches counter clockwise and open the door.
4. Disconnect the flow switch connector from the circuit board assembly and secure by hand to ensure the wiring is not damaged during this process. See lower inset in Figure 18.

5. Loosen the upper and lower union fittings and remove the variable speed check valve from the intake manifold assembly to access the orifice plate. See upper inset in Figure 18.

NOTE: Give attention to pipe connector leading to intake opening.

6. Remove the orifice plate from the upper variable speed check valve opening. See upper inset in Figure 18.
7. Replace with new orifice plate seated into the upper variable speed check valve opening.
8. Reinstall the variable speed check valve into the intake manifold assembly and tighten the upper and lower union fittings securely by hand. Do not over-tighten.
9. Reconnect the flow switch connector to the circuit board assembly. See lower inset in Figure 18.
10. Turn water and power ON at their sources.
11. Secure the door to the housing once system is operational.

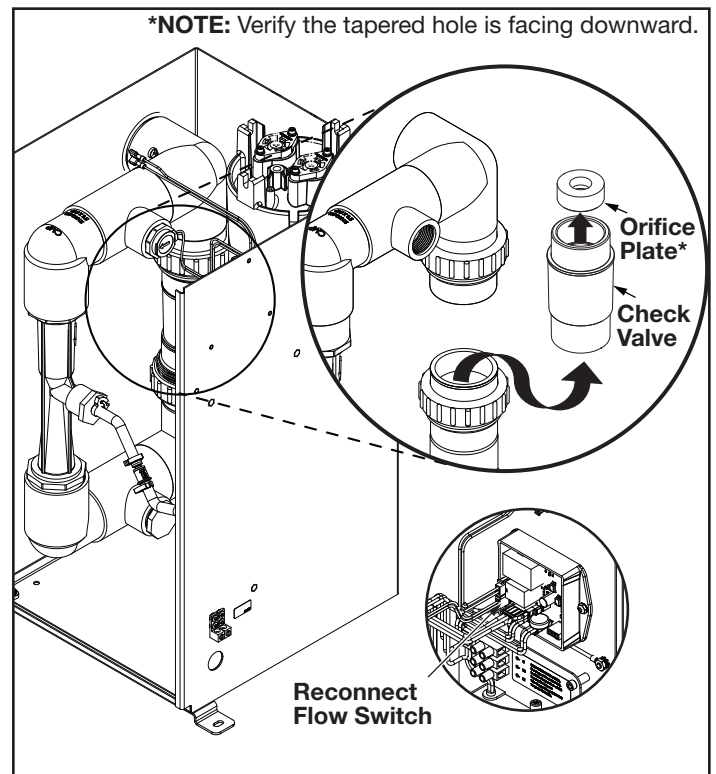

Figure 18. JAOPX200 Orifice Plate Location

5.9 Circuit Board

⚠ WARNING

ELECTRIC SHOCK HAZARD: Be sure to turn power OFF and disconnect from power source before any service work is performed. Failure to do so could result in serious injury or death.

Never attempt any servicing while unit is wet.

1. Shut off power at the breaker.
2. Shut off water to the unit.
3. Use a flat blade screwdriver to turn the door latches counter clockwise and open the door.
4. At the power PCB assembly, disconnect the following connectors: panel switch, flow switch, input power (from terminal block), ozone module(s), and ballast connectors. See Figure 20.
5. Remove the power PCB assembly from the Jandy AOP housing using a wrench.
6. Disconnect the LED PCB connector from the wire harness connector (on the door). See Figure 19.

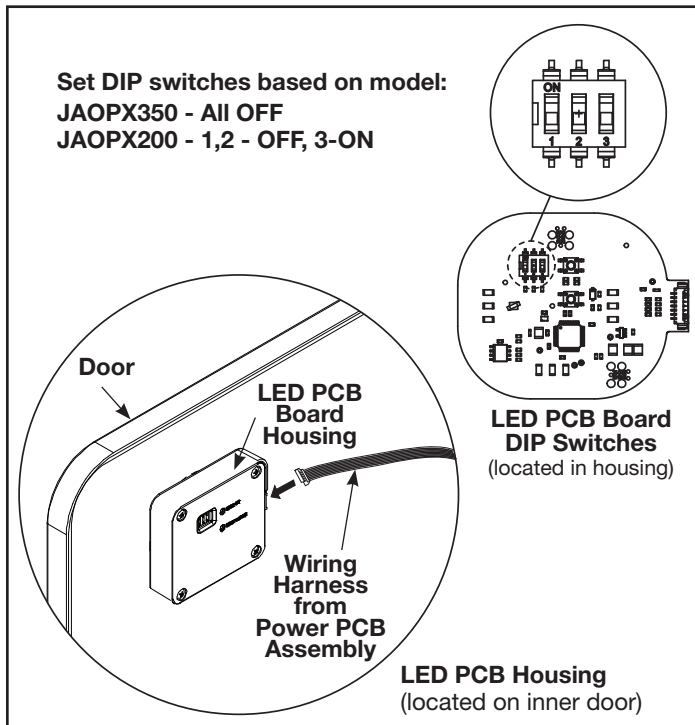

Figure 19. LED PCB Assembly On Door

7. Using a Phillip-head screwdriver, remove the four (4) screws and back cover over the LED PCB on the door. See Figure 19.
8. Remove the old LED PCB board assembly and set aside.

9. Secure the new power PCB assembly to the Jandy AOP housing using a wrench.
10. Secure the new LED PCB into the LED display and reinsert the connector to the wire harness. Replace the back cover onto the LED PCB using the four (4) screws previously removed.
11. Set the LED PCB board assembly DIP switches based on the model as shown. See Figure 19:
 - JAOPX350 - DIP switches 1,2, and 3: OFF
 - JAOPX200 - DIP switches 1,2: OFF and 3 ON
12. At the power PCB assembly, reconnect the panel switch, flow switch, input power (from terminal block), ozone module(s), and ballast connectors. See Figure 20.
13. Turn power and water ON from their sources.
14. Close the door and turn the door latches to secure once the system is operational.

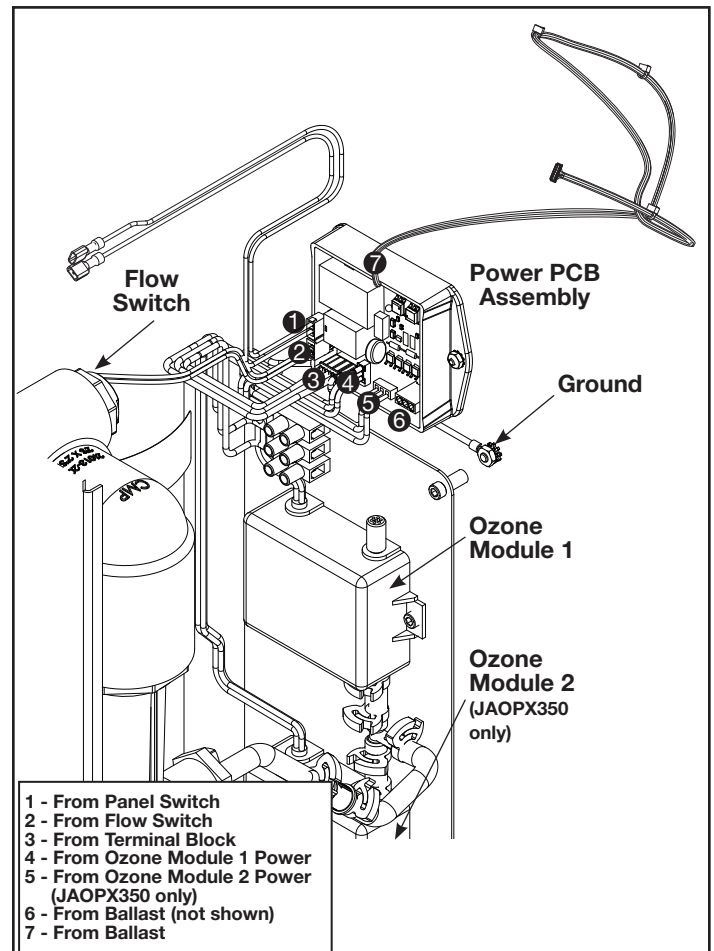

Figure 20. LED PCB Board and Power PCB Board Assemblies Wiring Connections

5.10 Ballast

The ballast regulates the voltage and current to the UV lamps and provide electrical connectivity to assist in operating the entire Jandy AOP system. The ballast is mounted on the underside of the top of the enclosure.

⚠ WARNING

ELECTRIC SHOCK HAZARD: Be sure to turn power OFF and disconnect from power source before any service work is performed. Failure to do so could result in serious injury or death.

Never attempt any servicing while unit is wet.

1. Shut off power at the breaker.
2. Shut off water to the unit.
3. Use a flat blade screwdriver to turn the door latches counter clockwise and open the door.
4. Locate the UV lamp access panel on the top of the Jandy AOP. Remove the four (4) screws with a Phillips head screwdriver, and remove the panel. See Figure 21.
5. Before continuing, allow adequate time for the quartz tubes to cool.
6. Disconnect the lamp connectors from the ballast wire connectors. See Figure 20.
7. Disconnect all of the wiring connecting the Jandy AOP system to the ballast and secure away from the work area to avoid damaging the wiring.
8. Unscrew the connection hardware to remove the old ballast and set aside.
9. Secure the new ballast onto the underside of the top of the enclosure with the provided hardware.
10. Reconnect all of the wiring connecting the Jandy AOP system to the ballast. See Figure 21.
11. Reconnect the lamp connectors to the ballast wire connectors.

NOTE: Either lamp connector can be connected to either ballast wire connector.

12. Replace the UV Lamp Access Panel onto the top of the housing with the provided hardware. Then secure the door to the housing once system is operational.
13. Turn ON power and water at their sources.

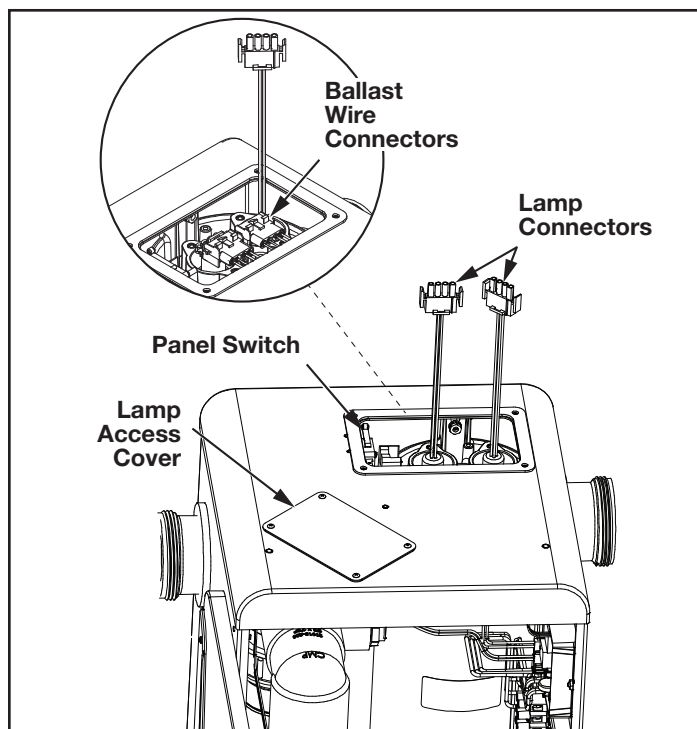

Figure 21. Jandy AOP System UV Reactor Lamp Access

Section 6. Troubleshooting & FAQ

NOTE: Knowledge of electrical applications is required for some troubleshooting. Contact a certified electrician if you are unsure of your ability to service the equipment. Improper servicing may void generator warranty. If any condition persists, contact Technical Support at 800.922.7933.

6.1 System Status Indicator Troubleshooting

Power Indicator Color	Ozone Indicator Color	UV-C Indicator Color	Cause	Corrective Action
Green	Blue	Purple	All systems are operating correctly	N/A
Green	Blue	Yellow	UV lamps are due for replacement	Order new UV lamps; see section 5.3 <i>UV System Maintenance</i>
Green	Blue	Red Blinking	UV lamps overdue for replacement	Replace UV lamps; see section 5.3 <i>UV System Maintenance</i>
Green	Yellow	Purple	Ozone modules are due for replacement	Order new ozone modules; see section 5.2 <i>Ozone System Maintenance</i>
Green	Red Blinking	Purple	Ozone modules overdue for replacement	Replace ozone modules, see section 5.2 <i>Ozone System Maintenance</i>
Green	Blue	Red	Error with UV-C system	Check UV lamp connections
				Check connection to ballast
				UV lamp failure: replace UV lamps
				Ballast failure: contact Technical Support
Green	Red	Purple	Error with ozone system	Check power connections to ozone modules
				Replace ozone modules, see section 5.2 <i>Ozone System Maintenance</i>
Red	Off	Off	Flow problem	Insufficient flow: verify that pump is running properly and that filters/skimers are clean
				Flow switch failure: replace flow switch
				Flow switch relay failure: replace flow switch
		UV panel switch error	UV access door is not properly closed	
			Panel switch has failed: contact Tech Support	

Power Indicator Color	Ozone Indicator Color	UV-C Indicator Color	Cause	Corrective Action
Off	Off	Off	No power to system from power source	Check circuit breaker at distribution box
				Check for loose connections or wiring breaks in the lines leading to the terminal block
				Incorrect wiring: confirm unit is connected to the output side of the pool time clock
			LED indicators malfunction	Loose or missing connections to LED indicators: check power connection to the back of the LED indicators inside the unit door
LED Indicators have failed: contact Technical Support				

6.2 System Troubleshooting

Symptom	Cause	Corrective Action
Green ozone module light is not illuminated while the system is running.	Error or failure with ozone module	Check power connections to ozone module
		Replace ozone module, see section 5.2 <i>Ozone System Maintenance</i>
One or more UV lamps are not lit when the unit is running.	Bad connection	Check UV lamp connector plug
	Water fouling has shorted UV lamp connection	Replace UV lamp, see section 5.3 <i>UV System Maintenance</i>
	Bad UV lamp	Replace UV lamp, see section 5.3 <i>UV System Maintenance</i>
	Ballast failure	Contact Technical Support

6.3 Frequently Asked Questions

1. How often does the UV lamp need to be replaced?

- UV lamps should be replaced after 16,000 hours of operation.
- The UV-C status indicators on the front of the unit will change to yellow when UV lamp replacement is due (a blinking red indicates it is overdue). This is when you should order new UV lamps or schedule service. The indicator will change to flashing red when service is overdue.

2. How often does the ozone module need to be replaced?

- Ozone modules should be typically be replaced after 12,000 hours of operation for optimal performance.
- The Ozone status indicators on the front of the unit will change to yellow when ozone module replacement is due (a blinking red indicates it is overdue). This is when you should order new ozone modules or schedule service. The indicator will change to flashing red when service is overdue.

3. When should other components be replaced?

- The ozone gas line assembly should be replaced yearly for best performance.
- The air filter or injector tube should be replaced if worn or dirty.
- The quartz tube should be replaced if it is scratched or damaged. It should be cleaned every six (6) months.

4. What do I do about bubbles in the pool from the Jandy AOP unit?

- It is normal for bubbles to appear from one or more return lines coming from the Jandy AOP unit.
- If you prefer to stop all bubbles or have a vinyl liner pool, a Mixing De-gas Vessel (MDV) can be installed to eliminate all bubbles.

5. Will this system work with an in-floor cleaning system?

- In-floor cleaning systems create high back-pressure for all equipment on the pad. To prevent back-pressure from affecting the Jandy AOP unit, it should be installed on a separate return line from the in-floor cleaning system. See section 7.1 *Appendix A* for details.

Section 7. Appendices

7.1 Appendix A: Jandy AOP X Series Installation - System Plumbing

The Jandy AOP system works under vacuum. The injector draws the ozone/air gas mixture from the ozone modules and mixes it into the water leaving behind some undissolved gas bubbles. These bubbles can affect certain pool system components, so care must be taken when installing the Jandy AOP.

The diagrams below cover common plumbing configurations. For other configurations or installation questions, **please contact** Technical Support.

1. **Pool Cleaners:** (i.e. Polaris 360) Always plumb the cleaner T-fitting before the Jandy AOP to prevent gas from affecting the operation of the cleaner.
2. **Chlorine Generator:** A salt chlorine generator should be plumbed after the Jandy AOP system to prevent the trapped accumulation of hydrogen gas, a safety hazard.
3. **Chlorine Tab/Mineral Erosion Feeder:** Always plumb the Jandy AOP after any erosion feeder to avoid gas accumulating in the feeder. A corrosion resistant check valve must be installed between the feeder and the AOP system. If installing as a retrofit and a tab feeder cannot be relocated, an MDV unit is recommended in between the Jandy AOP system and the tab feeder.
4. **Water Features:** Avoid plumbing the Jandy AOP into any leg with excessive back pressure such as those going to fountains, restrictive wall fittings, etc.
5. **In-Floor Cleaning System:** The Jandy AOP must be on a different pool return leg than any in-floor cleaning system to avoid excess back pressure on the Jandy AOP. This will also prevent gas intrusion and high oxidizer levels in zone valve and cleaner heads.
6. **Jandy AOP:** The goal is for back pressure on the AOP to be minimal.

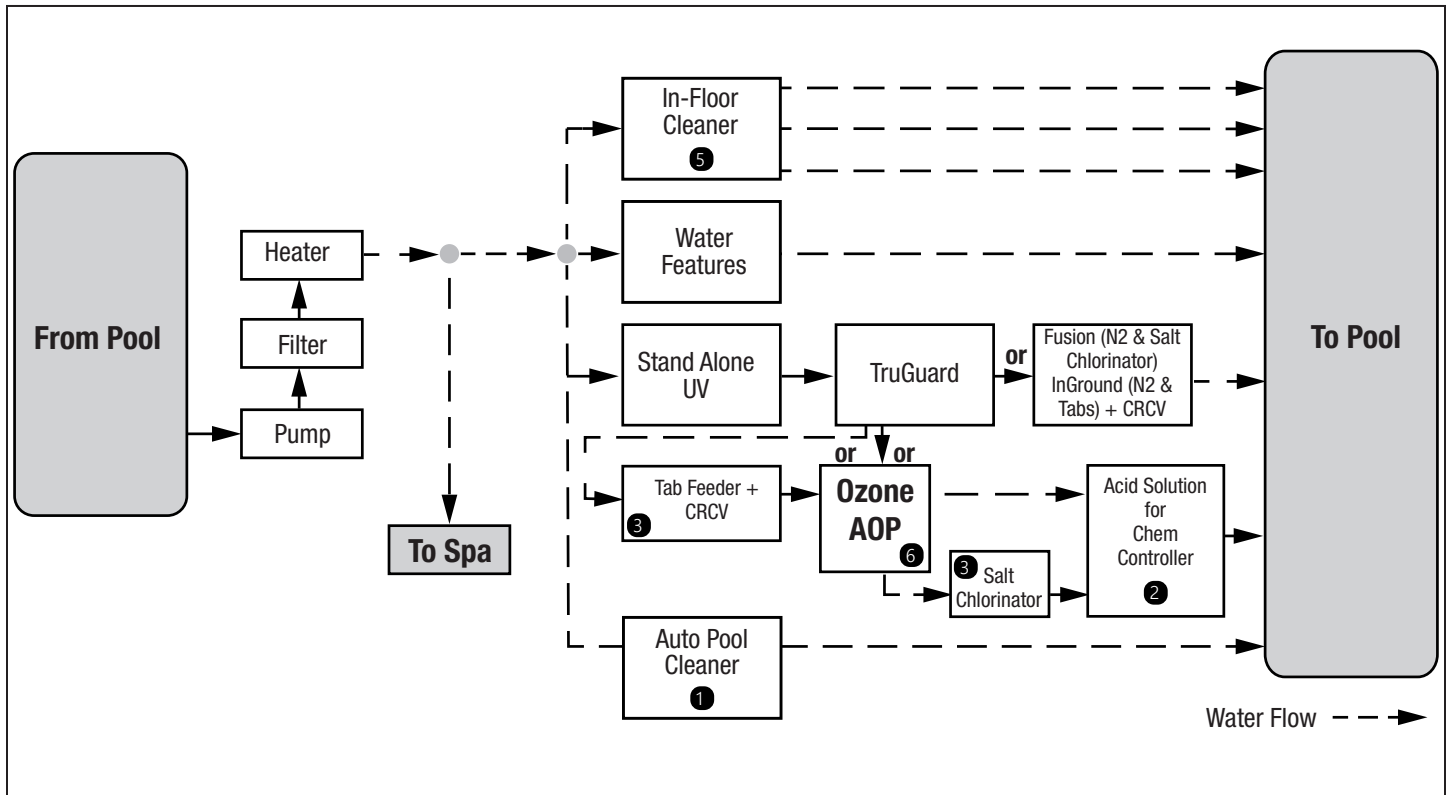

Figure 22. System Diagram

7.2 Appendix B: Jandy AOP Pressure Drop

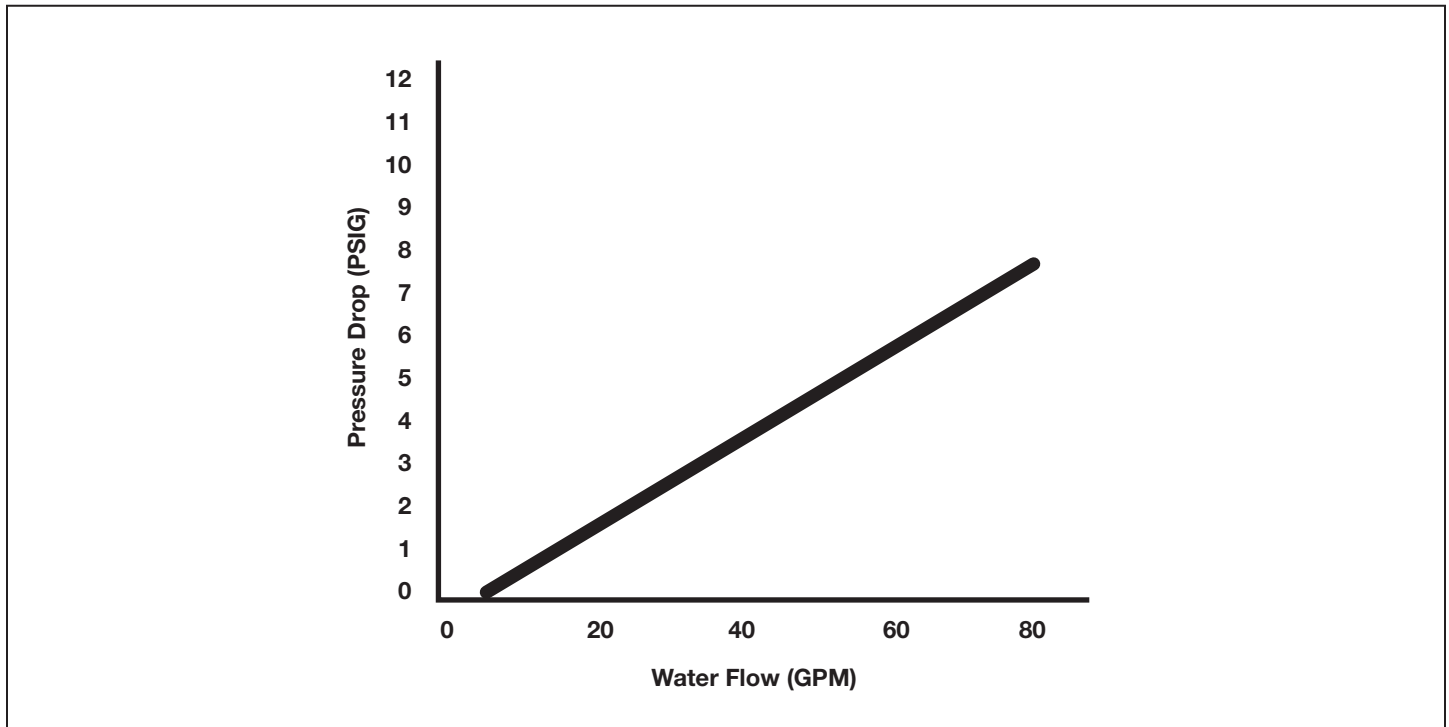

Figure 23. Pressure Drop Over a Range of Flows

NOTE: Tested on simulated recirculation system using a 3HP variable speed pump. Actual results will vary depending on pump and plumbing variables.

7.3 Appendix C: Optional In-Place Quartz Tube Cleaning

For regular cleaning, it is recommended to clean the quartz tube following the procedure in section 5.3.2 *Quartz Tube Removal and Cleaning (Every Six Months)*. If necessary, the AOP quartz tubes may alternatively be cleaned without removing them from the vessel by following the procedure below.

1. Ensure that the Jandy AOP is isolated from the rest of the pool system with shut-off valves at the inlet and outlet.
2. Disconnect the union from the outlet port on the right side of the unit and remove the winterizing cap inside the unit. See Figure 24.
3. Create an acidic cleaning solution of muriatic acid (available at all pool supply stores) and water in a ratio of four parts water to one part acid (4:1). Always observe all safety precautions as specified on the acid container.
4. Pour the cleaning solution in the winterizing port to flow from bottom to top. This may require creating a simple plumbing fixture to facilitate pouring in the winterizing port and filling to the top of the quartz tubes.
5. Allow the solution to soak as needed to remove any mineral build-up from the quartz tube. When cleaning is complete, drain the unit completely and clean any acidic cleaning solution that has collected in the bottom of the unit.
6. Run the pool system immediately for an extended period to fully rinse the internal components. Special considerations may apply depending on the cleaning system. Contact Customer Service if there is any question about compatibility with the Jandy AOP components.

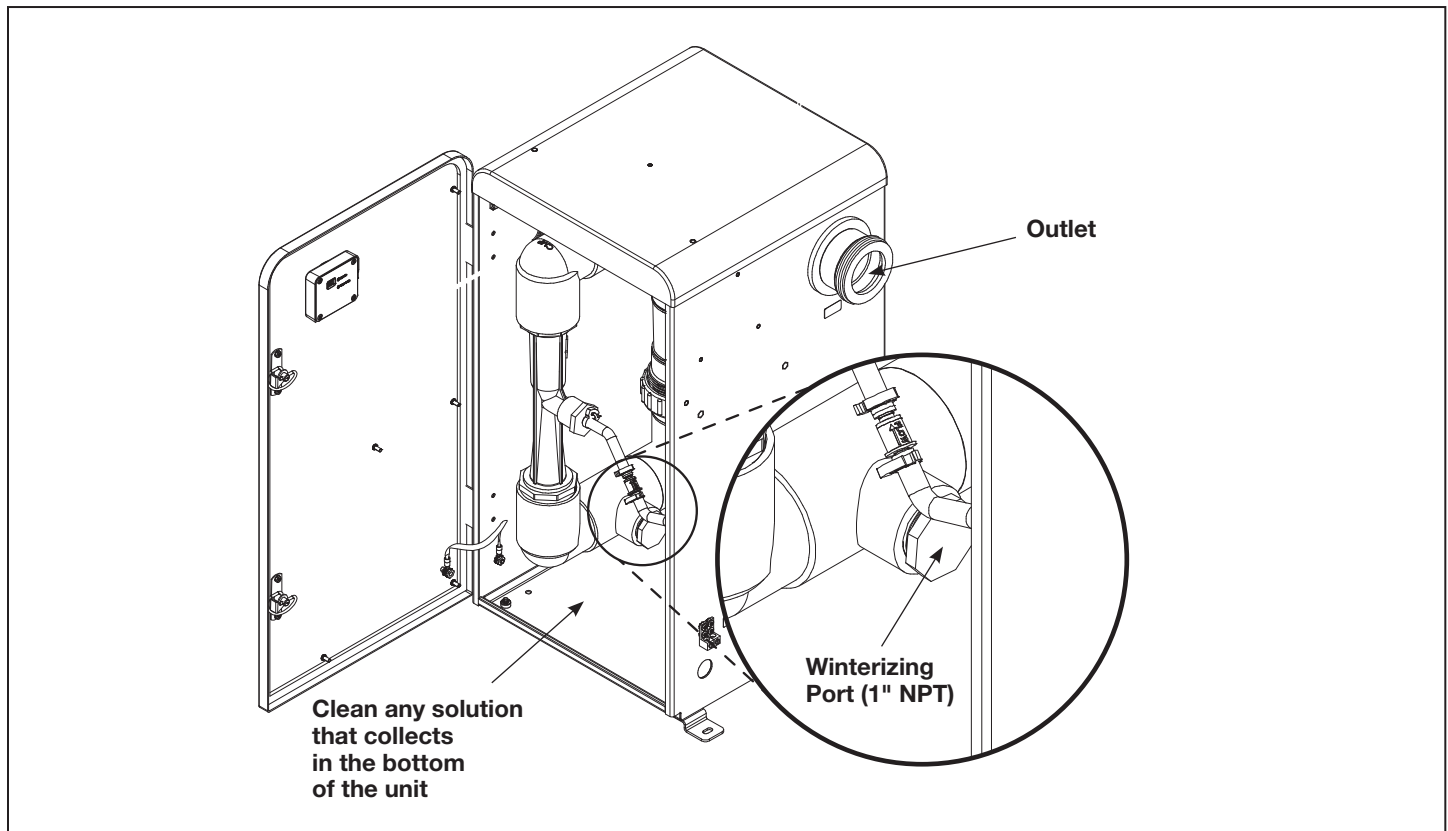

Figure 24. In-Place Quartz Tube Cleaning