

POOL LIFTS & ASSISTED ACCESS

Enabling equal access to aquatic facilities has always been a goal of Spectrum Aquatics®. We were proud to release our first aquatic lift in 1974 and after decades of refinement and technological advancement, we now offer over 20 different pool lift options. Choose between manually-powered, battery-powered and water-powered lifts – all with proprietary, robust operating systems. Our lifts offer ease of transfer while maintaining an open deck area. Spectrum Aquatics' lifts deliver optimal performance and withstand harsh aquatic environments — indoors and out.

ADA Compliance Overview

In 2010, the Federal Government approved into law the 2010 ADA Standards, requiring all commercial pools and spas to have an ADA-approved means of access by March 15, 2012. Compliance was later extended until January 31, 2013 and requires pools to install a ramp or a pool lift. A lift from Spectrum Aquatics® can help you easily achieve compliance.

WHAT MAKES A POOL LIFT COMPLIANT?

Required Lift Features:

- 300 lbs minimum weight capacity
- Capable of unassisted operation from deck and water
- Solid seat at least 16" wide
- Armrests are optional (*except in California*), but if included must be removable or fold clear of the seat
- Footrest (*not required with lifts used in spas*)
- Capable of lowering the seat to a minimum depth of 18" below the stationary water level

Lift Location Specifications:

- Located in less than 48" of water (unless entire pool depth is greater than 48")
- Seat centerline location must be a minimum of 16" from the edge of the pool in raised position
- Open deck space minimum of 36" wide that extends forward a minimum of 48" from a line located 12" behind the rear of the seat located on opposite side of the seat from the water
- Must be level, with a slope no greater than 1:48 (2%) in all directions

Lift Operation Specifications:

- Seat Height - Lift should allow for a stop between 16" and 19" above the top of the deck when in the raised position
- The controls and operating mechanisms should be unobstructed when the lift is in use
- Operation of the lift should not require tight grasping, pinching or twisting of the wrists to operate

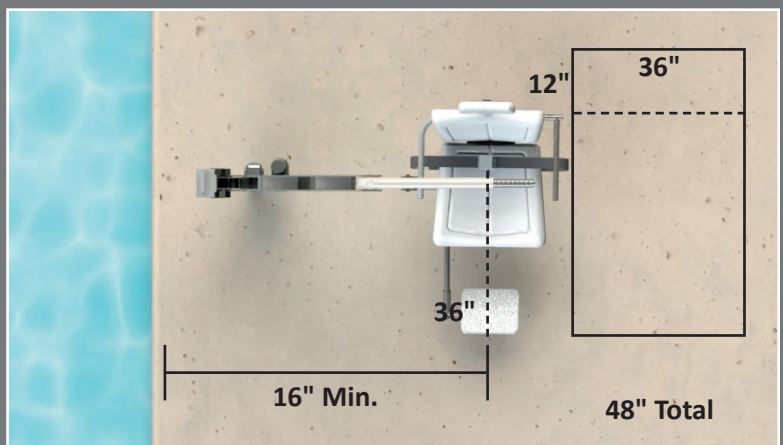
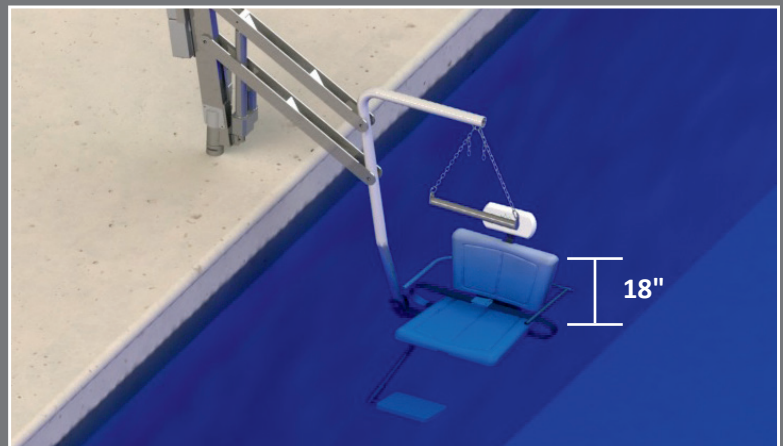

TRAVELER FAMILY

QUALITY & DURABILITY

- All stainless steel construction
- Triple protected for maximum corrosion resistance in harsh pool environments due to Spectra Shield® coating
- Electropolished and passivated
- Available in 316L

PERFORMANCE

- Avoids substantial repairs, labor costs and lift downtime
- Completely sealed waterproof battery
- Battery delivers 90 lifts between charges - no other lift manufacturer compares
- 350–500 lb. load capacity depending on model
- Rotationally & vertically powered with 360° continuous rotation
- Stabilizer bar improves ease of transfer
- Heavy duty actuator system

VERSATILITY

- Works with a broad range of deck configurations
- Offers setbacks ranging from 6" to 40" and a water draft up to 12"
- Allows loading and unloading from any desired position or angle
- Small footprint ideal for limited deck space
- Completely wireless system
- Wheelchair and spine board attachments available

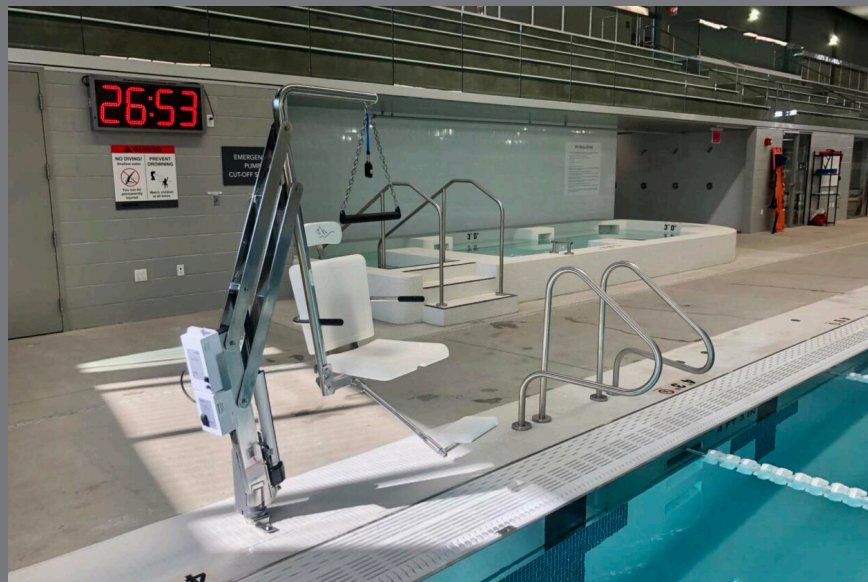
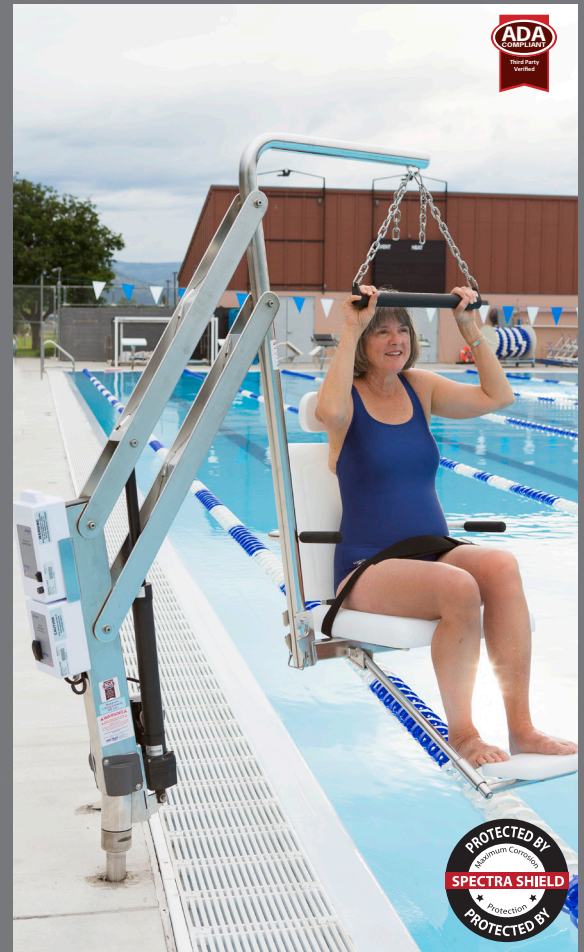

800.791.8056

BATTERY POWERED ADA POOL LIFTS



TRAVELER BP 500

- Wireless handset
- 500lb weight capacity
- Self-operable
- Spacious seat with excellent lumbar support designed for ease of transfer
- Quiet and stable operation
- Accommodates setback of 6" to 33" and water draft up to 12"
- Available in electropolished 316L stainless steel

27610 - TRAVELER BP 500

140290 - TRAVELER BP 500 316L



LONG REACH TRAVELER BP 350

- Wireless handset
- 350lb weight capacity
- Self-operable
- Spacious seat with excellent lumbar support designed for ease of transfer
- Quiet and stable operation
- Accommodates setback of 6" to 40" and water draft up to 12"

54129 - LONG REACH TRAVELER BP 350

