

ANCHOR CAP
REMOVAL TOOL

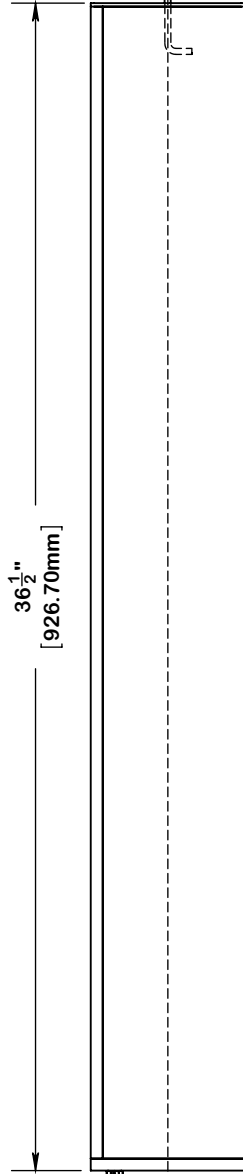

$4\frac{13}{16}$ "
[122.24mm]

ANCHOR CAP

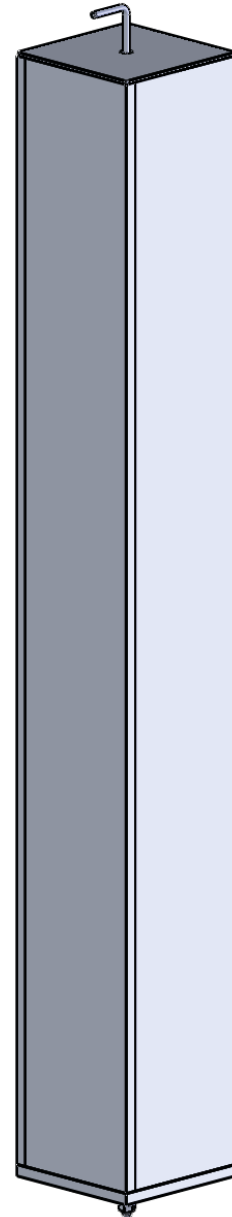
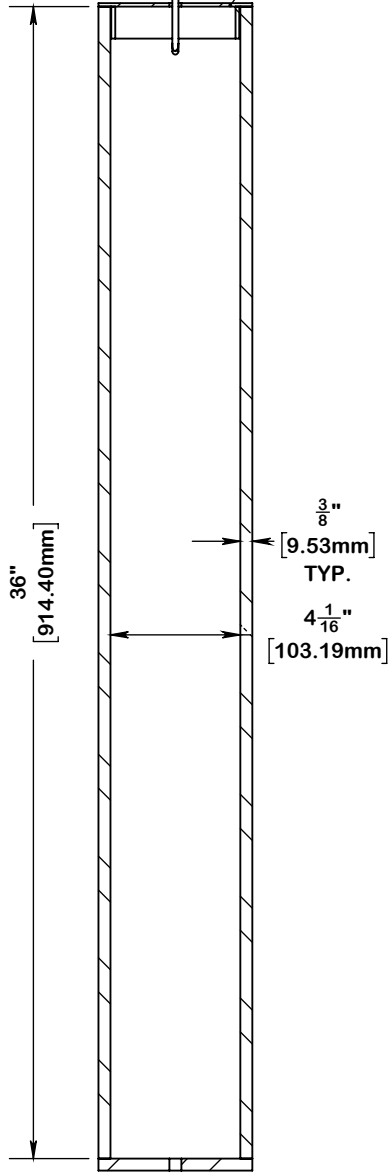

GROUNDING LUG

SECTION A-A

NOTE:

⚠ DIMENSIONS VARY WITH SPECIFIC APPLICATIONS. SPECIFICATIONS ARE NOMINAL AND ARE SUBJECT TO CHANGE. PLEASE CONTACT SPECTRUM AQUATICS FOR CUSTOM APPLICATIONS

SPECTRUM
Aquatics

A PLAYCORE Company

7100 Spectrum Lane
Missoula, Montana 59808
800.791.8056

www.spectrumaquatics.com

ENGINEERING DATA

PRODUCT:	ANCHOR - SQUARE 4"x36" 304L -		
MODEL #:	58782	CATALOG #:	58782
REVISION:	C		
MATERIAL:	304L STAINLESS STEEL		
FINISH #:	PASSIVATE IAW ASTM A967		