

ANCHOR CAP
REMOVAL TOOL → A

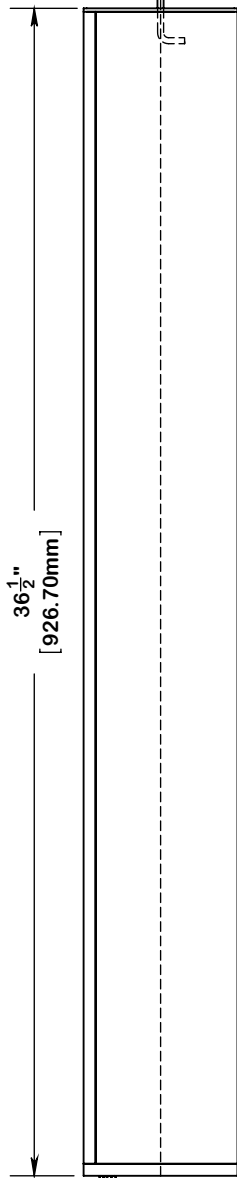

GROUNDING LUG

NOTE:

→ A

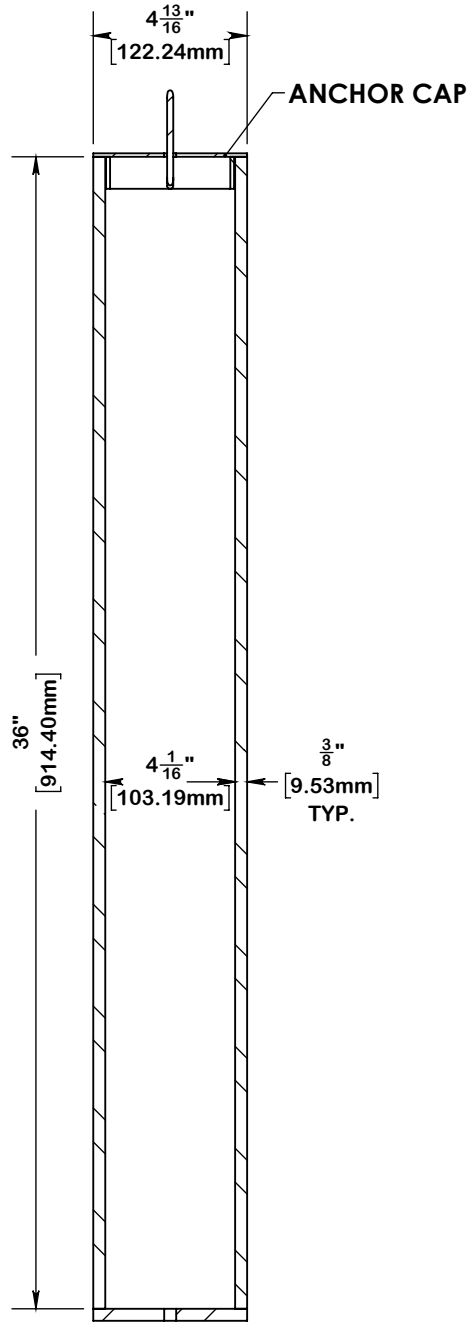

SECTION A-A

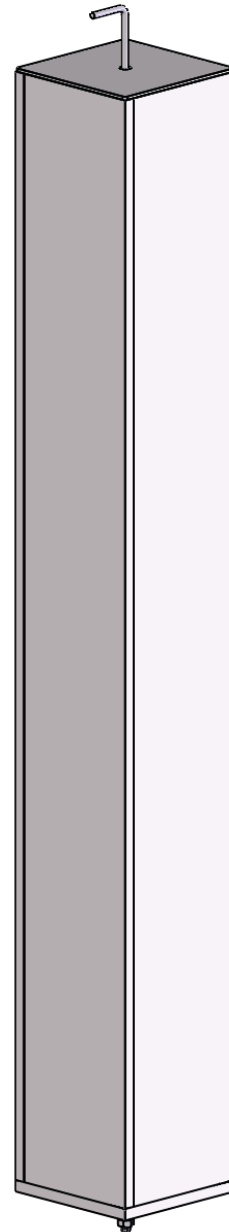

⚠ DIMENSIONS VARY WITH SPECIFIC APPLICATIONS. SPECIFICATIONS ARE NOMINAL, AND ARE SUBJECT TO CHANGE. PLEASE CONTACT SPECTRUM AQUATICS FOR CUSTOM APPLICATIONS

SPECTRUM
Aquatics

A PLAYCORE Company

7100 Spectrum Lane
Missoula, Montana 59808
800.791.8056

www.spectrumaquatics.com

ENGINEERING DATA

PRODUCT:	ANCHOR SQUARE 4"x36" - *316*		
MODEL #:	171060	CATALOG #:	171060
		REVISION:	B
MATERIAL:	316L STAINLESS STEEL		
FINISH #:	PASSIVATE IAW ASTM A967		