

MODEL 72

High Performance, High Head
Swimming Pool Pump



Features

- This high performance, high flow pump comes complete with our unique mechanical shaft seal that allows the pump, if mistreated, to run dry for up to one hour.
- The pump can be used for pool water with a salt concentration of up to 5000 ppm.
- Non-corrosive, chemical/UV resistant, and can withstand temperatures of up to 175°F.
- Suction and discharge are equipped with 2" or 3" quick disconnect unions for easy installation and maintenance.
- For pool users' safety, the impeller has a dielectric shaft sleeve that provides absolute separation between pool water and electric parts.
- Lock ring that incorporates handles. These handles provide the user with a convenient way to easily remove the lid.
- Heavy duty "1081" E-plus®/extreme-E™ energy efficient motors for extra low energy consumption. This large 56 frame motor is thermally protected, has a PSC switchless design and extra large sealed ball bearings.
- Motor is easy to remove without disturbing the plumbing. Reusable o-rings throughout.
- Every pump is performance tested before leaving the Speck factory.



Model 72-IV

Trademarks and Certifications



Applications

- In-ground pools
- Large residential and small commercial pools

Dimensional Drawing

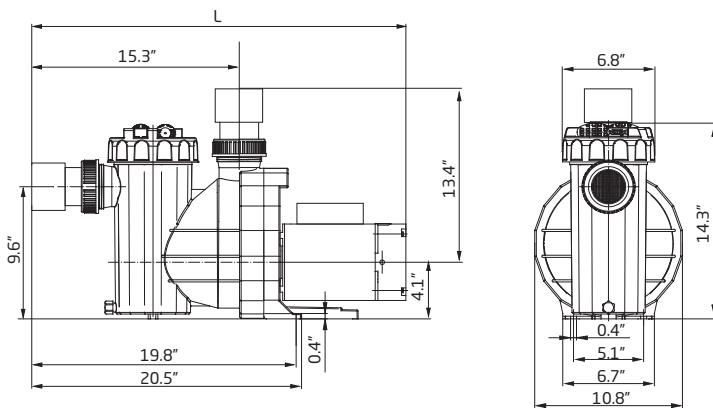

MODEL	DIMENSION "L"	SHIPPING WEIGHT
72-IV	29.0"	52 lbs.
72-V	29.0"	55 lbs.
72-VI	29.5"	56 lbs.

Performance Curves

