

Model A91-II VSP

Dual Voltage Variable Speed Pool Pump

SPECK X

Features

- This high performance, medium head pump comes complete with an industry standard Carbon/Ceramic 5/8" mechanical seal for convenient replacement.
- Non-corrosive, chemical/UV resistant, and can withstand temperatures of up to 150°F.
- Suction and discharge ports are equipped with quick disconnect unions. Provided with a standard 1.5" slip and 1.5"/1.25" hose adaptor connections. *Optional 1.5" NPT connections also available.*
- For pool users' safety, the impeller has a dielectric shaft sleeve that provides absolute separation between pool water and electric parts.
- Specially constructed clear lid with ring lock design is easy to open. Large strainer basket is always locked in place.
- Reusable o-rings throughout.
- Every pump is performance tested before leaving the Speck factory.

Features Specific to the 1.1 THP Dual Voltage Motor

- Pump is equipped with a 1.1 THP (48 frame thru-bolt mount) Variable Speed Motor.
- Pump motor runs on a wide voltage range 100-130/200-250V (without switching).
- Built-In Controller, LED Screen & Keypad can be locked for safety.
- 3 Adjustable Power Levels - Levels can be set to range from 50 Watts/1000 RPM to 1000 Watts/3500 RPM (in increments of 10 Watts).
- Programmable high efficiency TEFC (totally enclosed fan cooled) maintenance free permanent magnet brushless 48 frame motor.

Dimensional Drawing

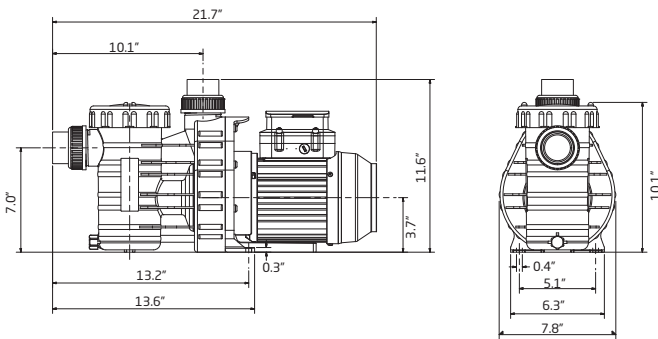

Technical Data

Order #	Model #	THP	WEF	Volts	Motor/Frame	Cord Set	List Price
AG215-V100T-000	A91-II VSP	1.1	10.9	115-230	TEFC/48	no cord	\$ 943.00
AG215-V100T-OST	A91-II VSP	1.1	10.9	115-230	TEFC/48	3' standard	961.00
AG215-V100T-OTL	A91-II VSP	1.1	10.9	115-230	TEFC/48	3' twist-lock	961.00



Trademarks and Certifications



Applications

- In-ground pools (small to medium)
- Residential pools

Performance Curves

