

BADU[®] Pro-III CVS (1.65 THP)

High Performance Swimming Pool Pump

A Drop in replacement design for Hayward[®] Super Pump[®] and Pentair[®] SuperFlo[®] pumps

Features

- The BADU Pro pump series saves you time & money while making your life simpler.
- Easily serviceable 4-bolt design & handle
- This high performance pump comes complete with our unique mechanical shaft seal that allows the pump, if mistreated, to run dry for up to one hour. The pump can be used for pool water with a salt concentration of up to 5000 ppm.
- Non-corrosive, chemical/UV resistant, and can withstand temperatures of up to 175°F.
- Lock ring that incorporates handles. These handles provide the user with a convenient way to easily remove the lid.
- Clear lid with LED light, allowing the user to check the basket for debris.
- Suction and discharge comes equipped with quick disconnect unions as well as internal threads for easy installation and maintenance.
- 1.65 THP Century[®] VGreen[®] Variable Speed motor comes complete with built-in controller Variable speed control, ranging from 600 to 3450 RPM. Levels can be set in increments of 250.
- Programmable high efficiency TEFC (totally enclosed fan cooled) maintenance-free permanent magnet brushless 56 frame motor with Class F insulation.
- Built-in timer (based on a 24 hour cycle).
- Digital inputs for compatibility with pool automation systems.
- **Remote Controller:** Optional VLink[™]
- Every pump is performance tested before leaving the Speck factory.

Dimensional Drawing

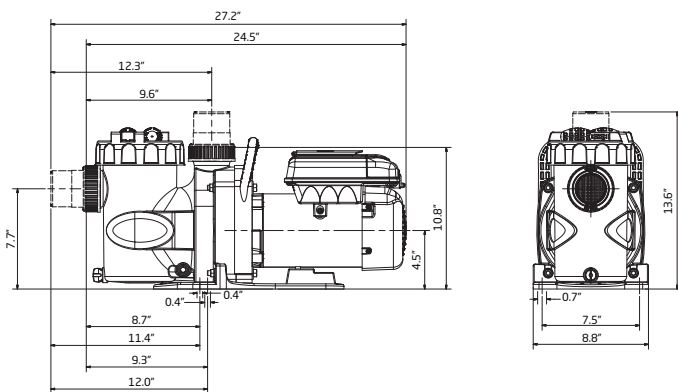

Hayward[®] and Super Pump[®] & Super III[™] are trademarks and/or registered trademarks of Hayward Industries, Inc. Pentair[®], SuperFlo[®] are trademarks and/or registered trademarks of Pentair Water Pool and Spa, Inc. and/or its affiliated companies.

SPECK X



BADU Pro-III CVS

Trademarks and Certifications



Applications

- Residential and small commercial pools & spas
- In-ground pools (small to medium)

VLink[™] Features

- The VLink[™] from Century Motors allows you to easily monitor and manage energy consumption and optimize your pool pump settings from a mobile device.
- Cloud connectivity and compatibility.
- Auxiliary control capability.

Performance Curve

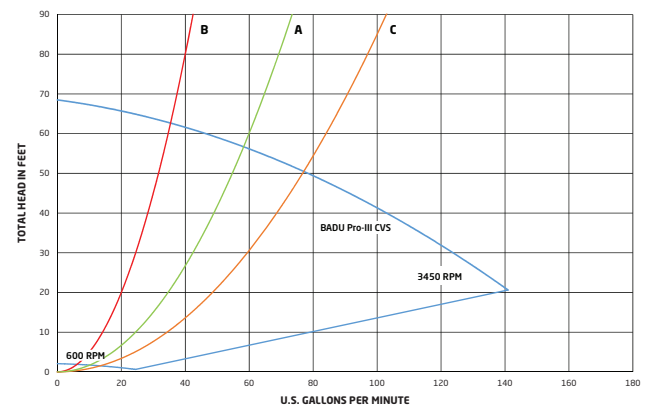

B, A, and C represent average system curves for pools with the pipe diameter mentioned below.

B = 1.5" pipe A = 2.0" pipe C = 2.5" pipe

BADU[®] Pro-V CVS (2.7 THP)

High Performance Swimming Pool Pump

A Drop in replacement design for Hayward[®] Super Pump[®] and Pentair[®] SuperFlo[®] pumps

Features

- The BADU Pro pump series saves you time & money while making your life simpler.
- Easily serviceable 4-bolt design & handle
- This high performance pump comes complete with our unique mechanical shaft seal that allows the pump, if mistreated, to run dry for up to one hour. The pump can be used for pool water with a salt concentration of up to 5000 ppm.
- Non-corrosive, chemical/UV resistant, and can withstand temperatures of up to 175°F.
- Lock ring that incorporates handles. These handles provide the user with a convenient way to easily remove the lid.
- Clear lid with LED light, allowing the user to check the basket for debris.
- Suction and discharge comes equipped with quick disconnect unions as well as internal threads for easy installation and maintenance.
- 2.7 THP Century[®] VGreen[®] Variable Speed motor with built-in easy to use controller LCD screen. (Also available with SVRS)
- RPM levels can be set to range from 600 to 3450. Levels can be set in increments of 25.
- Programmable high efficiency TEFC maintenance-free permanent magnet brushless 56 frame motor with Class F insulation.
- Freeze protection feature that can be turned ON/OFF or adjusted.
- Programmable auxiliary load feature.
- The controller can be removed and mounted away from the pump using the RS485 cable.
- **Remote Controller:** Optional VLink[™]
- Every pump is performance tested before leaving the Speck factory.

Dimensional Drawing

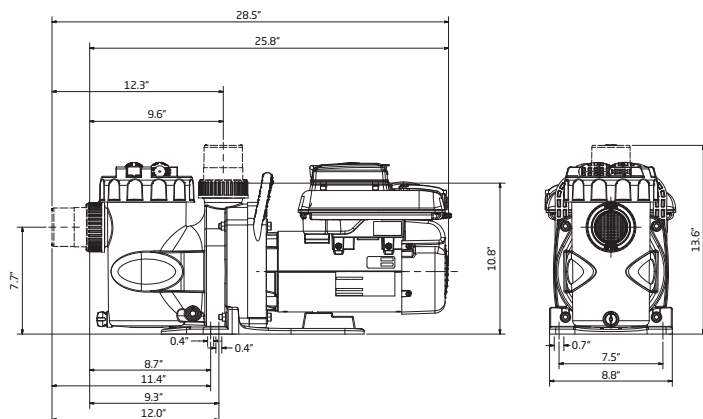

Hayward[®] and Super Pump[®] & Super II[™] are trademarks and/or registered trademarks of Hayward Industries, Inc. Pentair[®], SuperFlo[®] are trademarks and/or registered trademarks of Pentair Water Pool and Spa, Inc. and/or its affiliated companies.

8125 Bayberry Road, Jacksonville, Florida 32256 USA | Phone: (904) 739-2626 | Fax: (904) 737-5261

Website: www.speck-pumps.com



BADU Pro-V CVS

Trademarks and Certifications



Applications

- Large residential pools & spas
- Small commercial pools

VLink[™] Features

- The VLink[™] from Century Motors allows you to easily monitor and manage energy consumption and optimize your pool pump settings from a mobile device.
- Cloud connectivity and compatibility.
- Auxiliary control capability.

Performance Curve

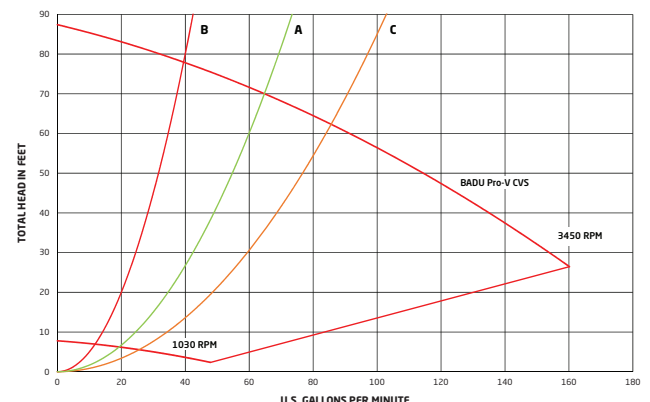

B, A, and C represent average system curves for pools with the pipe diameter mentioned below.

B = 1.5" pipe

A = 2.0" pipe

C = 2.5" pipe

Rev. 10/2019