

# BADU® Pro E Series (48 frame)



## Self-Priming High Flow Pump

A Drop in replacement design for Hayward® Super Pump® and Pentair® SuperFlo® pumps

### Features

- The BADU Pro pump series saves you time & money while making your life simpler.
- Easily serviceable 4-bolt design & handle
- This high performance pump comes complete with an industry standard Carbon/Ceramic 200 seal (5/8") for convenient replacement.
- Non-corrosive, chemical/UV resistant, and can withstand temperatures of up to 175°F.
- The BADU Pro is available with the following motors:
  - Single Speed (0.75 to 2.0 THP)
  - Variable Speed (1.1 THP)
- Lid lock ring that incorporates handles. These handles provide the user with a convenient way to easily remove the lid.
- Specially constructed clear lid. (Optional Clear lid with LED light available.)
- Suction and discharge come equipped with quick disconnect unions for easy installation and maintenance.
- Suction and discharge ports are also equipped with internal threads.
- Every pump is performance tested before leaving the Speck factory.

### Features Specific to the Single Speed Motors

- Motor is a energy efficient, switchless PSC motor.
- Dual voltage motor with toggle switch and has a stainless steel shaft.

### Features Specific to the 1.1 THP Dual Voltage Motor

- Clear lid with LED light, allowing the user to check the basket for debris.
- Pump is equipped with a 1.1 THP variable speed motor.
- Motor runs on a wide voltage range 100-130/200-250V. Automatically detects 115 or 230V.
- Built-In Controller, LED Screen & Keypad can be locked for safety.
- 3 Adjustable Power Levels - Levels can be set to range from 50 Watts/1000 RPM to 1000 Watts/3500 RPM (in increments of 10 Watts).
- Programmable high efficiency TEFC (totally enclosed fan cooled) maintenance free permanent magnet brushless motor.

### Technical Data

Order #	Model #	THP	WEF	Volts	Motor	Port Size	List Price
<b>Single Speed</b>							
IG371-1075T-000	BADU Pro-I E SSP	0.75	3.85	115/230	PSC	1.5"	\$ 510.00
IG371-1100T-000	BADU Pro-II E SSP	1.0	3.59	115/230	PSC	1.5"	553.00
IG371-1150T-000	BADU Pro-III E SSP	1.5	-	115/230	PSC	1.5"	619.00
IG371-1200T-000	BADU Pro-IV E SSP	2.0	-	230	PSC	1.5"	664.00
<b>Variable Speed - Energy Star Listed</b>							
IG375-V100T-000	BADU Pro-II E VSP	1.1	11.2	115-230	TEFC	1.5"	1,156.00



BADU Pro-II E VSP

BADU Pro-I E SSP

### Trademarks and Certifications



Select BADU Pro models are ENERGY STAR certified

### Applications

- Residential pools & spas
- In-ground pools (small to medium)

### Dimensional Drawing

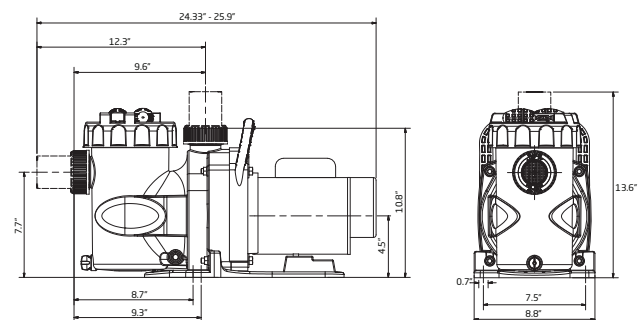

Hayward® & Super Pump® are trademarks and/or registered trademarks of Hayward Industries, Inc.  
Pentair® & SuperFlo® are trademarks and/or registered trademarks of Pentair Water Pool and Spa, Inc. and/or its affiliated companies.

8125 Bayberry Road, Jacksonville, Florida 32256 USA | Phone: (904) 739-2626 | Fax: (904) 737-5261  
Website: www.speck-pumps.com

Rev. 01/2021

# BADU<sup>®</sup> Pro E Series (48 frame)

Self-Priming High Flow Pump



## Performance Curves

### Single Speed Models

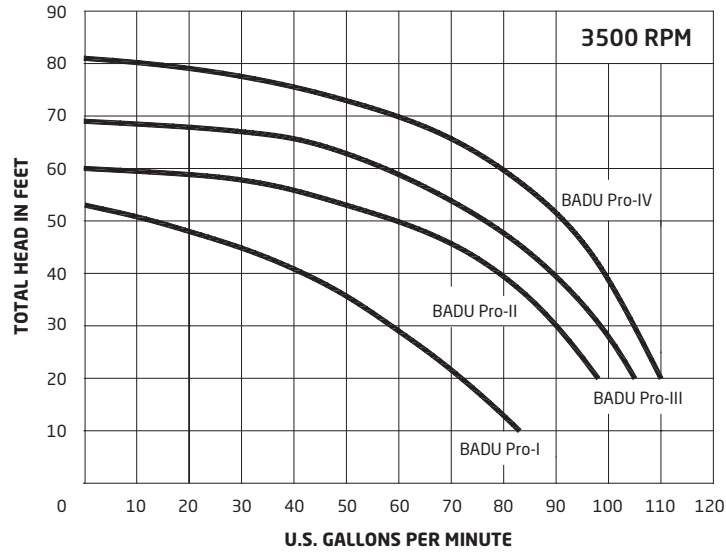

### 1.1 Dual Voltage Variable Speed Model

