

Installation, Operating, and Service Manual

BADU[®] EcoM3 V (1.65)

Variable Speed Pool Pump



SPECK X
pumps

Technical Support

Address: Speck Pumps
8125 Bayberry Road
Jacksonville, FL. 32256
USA

Hours: (Monday - Friday) 8:00 am to 5:00 pm EST

Toll Free: (800) 223-8538

Phone: (904) 739-2626

Fax: (904) 737-5261

Website: www.usa.speck-pumps.com

Email: technical.usa@speck-pumps.com

*Manufactured by Speck Pumps, Jacksonville Florida USA, © 2016 All Rights Reserved.
This document is subject to change without notice.*

Date of Installation:	
Installed by:	
Serial Number:	
For Service Call:	

Safety

Safety is emphasized throughout the user manual. These are safety alert symbols (**CAUTION**, **WARNING**, and **DANGER**). They alert the user to potential personal injury hazards. Obey all safety messages to avoid possible injury or death or damage to equipment.

SAVE THESE INSTRUCTIONS!

Table of Contents

1	<i>Important Safety Instructions</i>	4
2	<i>General Description</i>	6
3	<i>Installation Information</i>	7
	Preparation Guide	7
	Pump Location	7
	Pipe Sizing	8
	Plumbing Installation	8
	Bonding and Grounding	9
	Electrical Installation	9
	Pressure Testing	10
4	<i>Operation</i>	11
	Start-Up Guide	11
	Energy Savings Optimization	12
	Programming	12
	Menu Structure	13
	Keypad Lock	15
	Motor Pause	15
	Power Outage	15
	Schedule Advance.	16
	Using an existing or new 24 hour timer	16
	Optional Controller	16
	Freeze Protection	17
	Override	17
	Communication	17
	3rd Party Controllers (Wiring).	19
	Heat Pump Pool Heater Connections (Wiring).	23
5	<i>Service and Maintenance</i>	25
	Routine Maintenance	25
	Winterizing	26
6	<i>Troubleshooting</i>	26
	Fault LED.	26
	General Troubleshooting Problems	27
	Blocked Impeller	27
	Removal and Replacement of the Impeller	28
	Motor Replacement	29
7	<i>Product Specifications</i>	30
	Performance Curve & Dimensional Drawing	30
	Replacement Parts and Exploded View	31
8	<i>Limited Warranty</i>	32

1 Important Safety Instructions

READ THIS MANUAL CAREFULLY BEFORE USING THE PUMP

READ AND FOLLOW ALL INSTRUCTIONS!

Important Notice:

This manual contains important information about the installation, operation and safe use of this product. This information should be given to the owner and/or operator of this equipment.

WARNING: *This product must be installed and serviced by a qualified pool professional, and must conform to all national, state, and local codes.*

WARNING: *Before Installing this product, read and follow all warning notices and instructions which are included. Failure to follow safety warnings and instructions can result in severe injury, death, or property damage.*

Call (800) 223-8538 or visit www.usa.speck-pumps.com for additional copies of these instructions.

When installing and using this electrical equipment, basic safety precautions should always be followed, including the following:

READ AND FOLLOW ALL INSTRUCTIONS

WARNING: *To reduce the risk of injury, do not permit children to use this product unless they are closely supervised at all times.*

WARNING: *Risk of Electrical Shock. Connect only to a grounding type receptacle protected by a ground-fault circuit-interrupter (GFCI). Contact a qualified electrician if you cannot verify that the receptacle is protected by a GFCI.*

The unit must be connected only to a supply circuit that is protected by a ground-fault circuit-interrupter (GFCI). Such a GFCI should be provided by the installer and should be tested on a routine basis. To test the GFCI, push the test button. The GFCI should interrupt power. Push the reset button. Power should be restored. If the GFCI fails to operate in this manner, the GFCI is defective. If the GFCI interrupts power to the pump without the test button being pushed, a ground current is flowing, indicating the possibility of an electric shock. Do not use this pump. Disconnect the pump and have the problem corrected by a qualified service representative before using.

CAUTION: *This pump is for use with permanently installed pools and may also be used with hot tubs and spas if so marked. Do not use with storable pools. A permanently installed pool is constructed in or on the ground or in a building such that it cannot be readily disassembled for storage. A storable pool is constructed so that it may be readily disassembled for storage and reassembled to its original integrity.*

TO REDUCE THE RISK OF ELECTRICAL SHOCK, *connect ground wires to grounding screw located in the motor. Use no smaller than a #12 AWG (3.3mm²) wire.*

TO REDUCE THE RISK OF ELECTRICAL SHOCK, *a bonding connector is provided for bonding to metal water pipes, metal rails, or other metal within 5 feet of the swimming pool. All local points should be bonded with a #8 AWG (8.4mm²) wire.*

SAVE THESE INSTRUCTIONS.

WARNING - Entrapment Prevention



DANGER: DO NOT BLOCK SUCTION

SUCTION HAZARD. *Can cause serious injury or death. Do not use this pump for wading pools, shallow pools, or spas containing bottom drains, unless pump is connected to at least two (2) functioning suction outlets.*

WARNING: *Pump suction is hazardous and can trap and drown or disembowel bathers. Do not use or operate swimming pools, spas, or hot tubs if a suction outlet cover is missing, broken, or loose.*

The following guidelines provide information for pump installation that minimizes risk of injury to users of pools, spas, and hot tubs:

Entrapment Protection: *The pump suction system must provide protection against the hazards of suction entrapment.*

Suction Outlet Covers: *All suction outlets must have correctly installed, screw-fastened covers in place. All suction outlet (drain) covers must be maintained. Drain covers must be listed/certified to the latest published edition of ANSI/ASME A112.19.8 (ANSI/APSP-16, 2011). They must be replaced if cracked, broken, or missing.*

Number of Suction Outlets Per Pump: *Provide at least two (2) hydraulically-balanced main drains, with covers, as suction for each circulating pump suction line. The centers of the main drains (suction outlets) on any one (1) suction line must be at least three (3) feet apart, center to center.*

The system **must** be built to include at least two (2) suction outlets (drains) connected to the pump whenever the pump is running. However, if two (2) main drains run into a single suction line, the single suction line may be equipped with a valve that will shut off both main drains from the pump. The system shall be constructed such that it shall not allow for separate or independent shutoff or isolation of each drain. More than one (1) pump can be connected to a single suction line as long as the requirements above are met.

Water Velocity: *The maximum water velocity through the suction fitting or cover for any suction outlet must be 1.5 feet per second, unless the outlet complies with the latest published edition of ANSI/ASME A112.19.8 (ANSI/APSP-16, 2011), the standard for Suction Fittings For Use in Swimming and Wading Pools, Spas, Hot Tubs, and Whirlpool Bathtub Applications. In any case, do not exceed the suction fitting's maximum designed flow rate.*

If 100% of the pump's flow comes from the main drain system, the maximum water velocity in the pump suction hydraulic system must be six (6) feet per second or less, even if one (1) main drain (suction outlet) is completely blocked. The flow through the remaining main drain(s) must comply with the latest published edition of ANSI/ASME A112.19.8 (ANSI/APSP-16, 2011), the standard for Suction Fittings For Use in Swimming and Wading Pools, Spas, Hot Tubs, and Whirlpool Bathtub Applications.

Testing and Certification: *Suction outlet covers must have been tested by a nationally recognized testing laboratory and found to comply with the latest published edition of ANSI/ASME A112.19.8 (ANSI/APSP-16, 2011), the standard for Suction Fittings For Use in Swimming and Wading Pools, Spas, Hot Tubs, and Whirlpool Bathtub Applications.*

Fittings: *Fittings restrict flow; for best efficiency use fewest possible fittings (but at least two (2) suction outlets). Avoid fittings that could cause an air trap. Pool cleaner suction fittings must conform to applicable International Association of Plumbing and Mechanical Officials (IAPMO) standards.*

WARNING - Risk of Electrical Shock or Electrocution

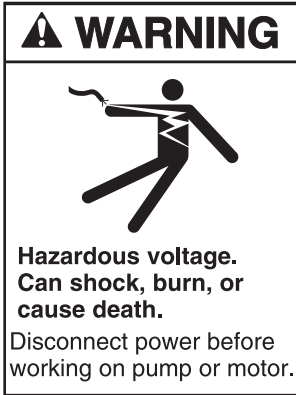

This pool pump must be installed by a licensed or certified electrician or a qualified pool serviceman in accordance with the National Electrical Code and all applicable local codes and ordinances. Improper installation will create an electric hazard which could result in death or serious injury to pool users, installers, or others due to electrical shock, and may also cause damage to property.

Always disconnect power to the pool pump at the circuit breaker before servicing the pump. Failure to do so could result in death or serious injury to serviceman, pool users, or others due to electric shock.

2 General Description

The Badu EcoM3 V (1.65) swimming pool pump is both environment friendly and cost efficient. This premium efficiency variable speed pump provides tremendous flexibility in motor speed and time settings. The integrated electronic interface controls the speed settings between 600 and 3450 rpm and the start and stop times. It is designed to maximize energy conservation, optimize chemical usage, and yet still be simplistic to use. The Badu EcoM3 V (1.65) is intended to run on the lowest speeds needed to maintain a healthy pool environment, which in turn translates into money savings. With speed settings of 3450, 3100, 2850, 2600, 2350, 2100, 1850, 1600, 1350, 1100, 850, 600, and 0, it easily allows you to choose the most appropriate speed for the maximum savings. With pump parts made of 100% recyclable plastic and engineering designed to significantly reduce greenhouse emissions, it is sure to please the environmentally minded consumer.

The affinity laws of hydraulics states that if you halve the speed, the power reduces by 8 times. The multiple speeds offered by the Badu EcoM3 V (1.65) enables it to run slower and consume less energy but still have the ability to run at full speed if required.

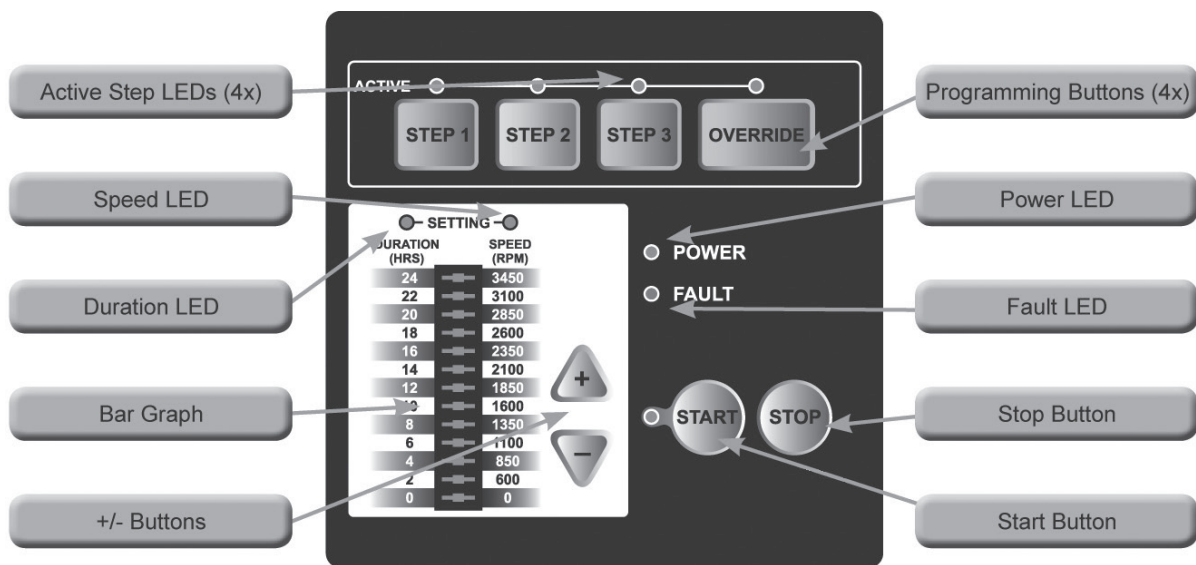

Figure 1

General Description - continued

The Badu EcoM3 V (1.65) control panel provides manual speed controls for the pump.

Controls and LEDs	Description
LED Lights (Active Step LEDs)	When lit, indicates it is in operation or active.
Speed LED	When lit, Bar Graph displays speed.
Duration LED	When lit, Bar Graph displays duration in hours speed will run.
Bar Graph	Shows current speed and duration (hours) of active programmed button or selected value during programming.
Programming Buttons	Four programmable buttons, to be set for speed and length of time.
Power LED	Indicates unit has power.
Fault LED	Indicates the unit has a fault error.
+/- Buttons	Increases or decreases speed or duration of selected value.
STOP button	Stops pump and programming.
START button	Must be pressed to start the pump and programming.

3 Installation Information

Preparation Guide

1. Upon receipt of the pump, check the carton for damage. Open the carton and check the pump for concealed damage, such as cracks, dents, or a broken base. If damage is found, contact the shipper or distributor where the pump was purchased.
2. Inspect the contents of the carton and verify that all parts are included. See *Section 7, Parts List and Exploded View for details*.

Pump Location

WARNING: *This product must be installed and serviced by a qualified pool professional, and must conform to all national, state, and local codes. Before installing this product, read and follow all warning notices and instructions of this product. Failure to follow warning notices and instructions may result in property damage, personal injury, or death.*

ATTENTION INSTALLERS: *This manual contains important information about the installation, operation, and safe use of this product. This manual should be given to the owner/operator of this equipment.*

1. In order to achieve better priming, to install the pump as close to the pool as practical and run suction lines as direct as possible to reduce friction loss.
2. It is recommended that a minimum length of straight pipe, equivalent to five (5) times the pipe diameter be used between the pump suction inlet and any plumbing fittings (elbows, valves, etc.).
3. Install the pump on a level, solid foundation which provides a rigid and vibration-free base. Secure the pump to the base with screws or bolts to further reduce vibrations and stress on the plumbing.

Pump Location - continued

4. Protect the pump against flooding and excess moisture. Select an area that will not flood when it rains. **DO NOT** install the pump in a damp or non-ventilated location.
5. Keep the motor clean and provide free circulation of air for cooling.
6. Though the pump is designed for outdoor use, it is advised to protect the pump from continuous direct heat. Install the pump in a well ventilated location protected from excessive moisture (flooding, sprinklers, rain downspouts, etc.).
7. **DO NOT** store or use gasoline or other flammable vapors or liquids in the vicinity of this pump. **DO NOT** store pool chemicals near the pump.
8. **DO NOT** remove any safety alert labels such as **DANGER**, **WARNING**, or **CAUTION**. Keep safety labels in good condition and replace any missing or damaged labels.
9. Provide access for future services by leaving a clear area around the pump. Allow plenty of space above the pump to remove lid and basket for cleaning.

WARNING: *Some Safety Vacuum Release System (SVRS) devices are not compatible with the installation of check valves. If the pool has an SVRS device, be sure to confirm that it will continue to safely operate when the check valves are installed.*

NOTE: In Canada, the pump must be located a minimum of three (3) meters (approximately ten (10) feet) from the water (CSA C22.1).

Pipe Sizing

NOTE: All pipe sizes are able to withstand the pressures the pump will deliver, but not necessarily the flow. If the pipe is too small for the pump, or is elevated above water, the maximum gallons per minute (GPM) may not be delivered. If this happens, the pump will develop a pocket of air (cavitation) that makes noise. This may shorten the life of the pump.

SUCTION & DISCHARGE:

When the pump is located up to fifty (50) feet from the pool, the recommended minimum pipe size for both the suction and discharge is 2".

For better efficiency and less restriction, use as few fittings (elbows, tees, valves, etc.) as possible.

Suction line diameter must be equal or be greater than the discharge line diameter.

Suction and discharge lines should be independently supported at a point near the pump to avoid strains being placed on the pump.

NOTE: If more than ten (10) suction fittings are needed, the pipe size must be increased.

Plumbing Installation

When installing the pump, care should be taken to see the suction line is below water level to a point immediately beneath and in front of the pump to ensure quick priming via a flooded suction line. The height between the pump and water level should not be more than five (5) feet.

Plumbing Installation - continued

If the pump is located below water level, isolation valves must be installed on both sides of the pump to prevent the back flow of pool water during any routine or required servicing. The Badu EcoM3 V (1.65) comes equipped with unions on both the suction and discharge ports. This feature simplifies installation and service and eliminates the possibility of leaks at the threaded adaptors.

Before starting the pump for the first time, remove the see-through lid. (Turn lid ring counter clockwise to remove.) Fill strainer tank with water until it is level with the suction inlet. Replace lid, making sure the o-ring is in place and not damaged. **Hand-tighten** the lid to make an air tight seal. ***DO NOT*** use any tools to tighten the lid: ***hand-tighten only***.

Every new installation must be pressure tested according to local codes. See the *Pressure Testing Section on page 10*.

Bonding and Grounding

WARNING: *Ground and bond the pump before connecting to electrical power supply. Failure to ground and bond the pump can cause serious or fatal electrical shock hazard. **DO NOT** ground to a gas supply line. To avoid dangerous or fatal electrical shock, turn OFF power to the pump before working on electrical connections.*

1. The motor frame must be grounded to a reliable grounding point using a solid copper conductor, No. 8 AWG or larger. In Canada, No. 6 AWG or larger must be used. If the pump is installed within five (5) feet of the inside walls of the swimming pool, spa, or hot tub, the motor frame must be bonded to all metal parts of the swimming pool, spa, or hot tub structure and to all electrical equipment, metal conduit, and metal piping within five (5) feet of the inside walls of the swimming pool, spa, or hot tub.

2. Bond the motor using the provided external lug.

WARNING: *In order to avoid the risk of property damage, severe personal injury, and/or death, make sure that the control switch, time clock, or control system is installed in an accessible location, so that in the event of an equipment failure or loose plumbing fitting, the equipment can be easily turned off.*

CAUTION: *The pump must be permanently connected to a dedicated electrical circuit. No other equipment, lights, appliances, or outlets may be connected to the pump circuit, with the exception of devices that may be required to operate simultaneously with the pump, such as a chlorinating device or heater.*

Electrical Installation

WARNING: *All electrical wiring must conform to the local NEC guidelines. A licensed, qualified electrician should complete the wiring for this product.*

Electrical Specifications:

- Voltage: 208-230 VAC, 60 Hz, Single Phase
- Max Amps: 11
- Speed Range: 600 - 3450
- Controller: 208-230 Vrms, Single Phase
- Ambient: 50° C
- NEMA Type 3R

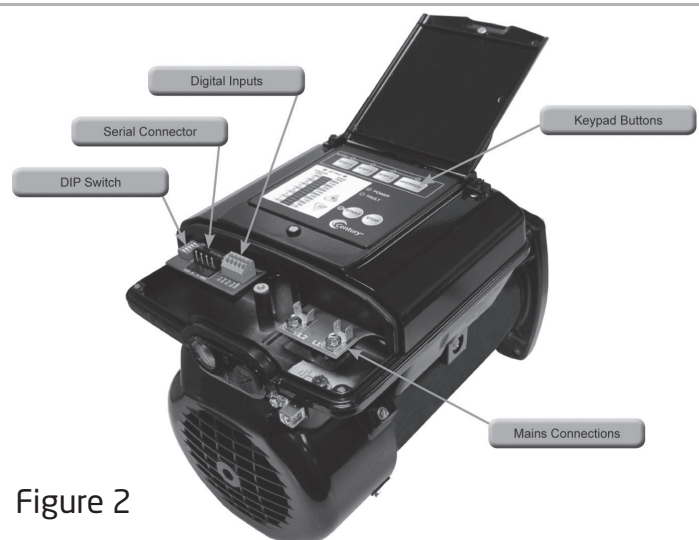

Figure 2

Electrical Installation - continued

The motor is designed to handle either a bare wire connection or a quick disconnect connection. The quick disconnect tab is 0.250". For a direct wire connection, the wire insulation should be stripped to a length of approximately 0.33" and the screw tightened to a torque of 10 in-lb. The terminals will handle wire up to 12 AWG in size.

There are two terminals labeled L1 and L2 (See Figure 3). Attach the power leads to these terminals. Attach the black lead to L1 and the red or white lead to L2 (See Table 1.0). The top rear of the controller has a single screw. Loosen this screw and lift cover to expose the terminal area.

Table 1.0

Pin#	Wire Color	Description
L1	Black	Hot 1
L2	Red or White	Hot 2
GRD	Green	Ground

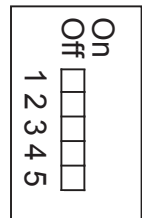

*NOTE: All Dip switches should be in the OFF position when external controllers are **not** being used.*

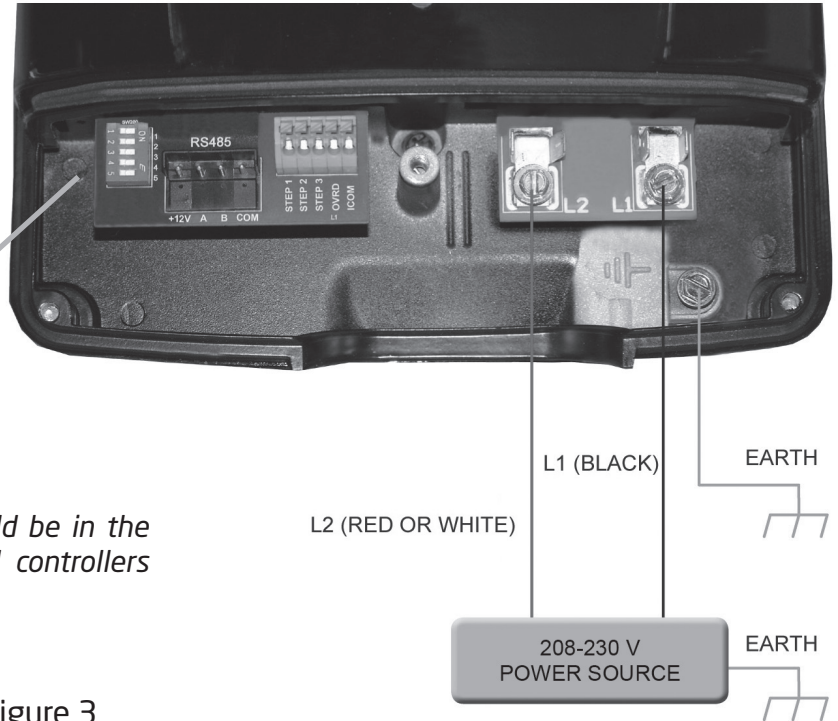

Figure 3

CAUTION: Voltage at the pump **MUST NOT** vary by more than +/- 10% of nameplate voltage. Components may overheat, causing overload tripping and reduced component life. Consult your power company if this condition exists.

NOTE: Use only liquid tight fittings to protect the electronics and motor.

Pressure Test

WARNING: To minimize the risk of severe injury or death, the filter and/or pump should not be subjected to the piping system pressurization test.

Local codes may require the pool piping system to be subjected to a pressure test. These requirements are generally not intended to apply to the pool equipment.

However, if the **WARNING** cannot be followed and pressure testing of the complete system must be done, follow the following guidelines:

1. RELEASE ALL AIR in the system before testing.

Pressure Test - continued

2. Water pressure for the test MUST NOT EXCEED 35 PSI.
3. Water temperature for the test MUST NOT EXCEED 100° F (38° C).
4. Limit the test to 24 hours. After the test, visually check the system to be sure it is ready for operation.

DO NOT USE COMPRESSED AIR TO PRESSURE TEST OR CHECK FOR LEAKS.

4 Operation

Start Up Guide

CAUTION: *Never run the pump without water. Running the pump “dry” for any length of time can cause severe damage to both the pump and the motor and will void the warranty.*

If this is a new pool installation, make sure all piping is clear of construction debris and has been properly pressure tested. The filter should be checked for proper installation, verifying that all connections and clamps are secure according to the manufacturer’s recommendations.

WARNING: *To avoid risk of property damage, severe personal injury or death, verify that all power is turned OFF before starting this procedure.*

1. Depending on the location of the pump, do one of the following:
 - If the pump is located **below** the water level of the pool, open the filter pressure valve to prime the pump with water. Once all the air has left the filter, close the filter pressure release valve.
 - If the pump is located **above** the water level of the pool, remove the lid and fill the basket with water before starting the pump.
2. Prior to replacing the lid, check for debris around the lid o-ring seat. Debris around the lid o-ring seat will make it difficult to prime the pump.
3. **Hand-tighten** the lid to make an air tight seal. **DO NOT** use any tools to tighten the lid: **hand-tighten only**. Make sure all valves are open and the unions are tight.
4. Restore power to the system.
5. Pressing the START key will start the motor based on the factory default schedule (*See Table 2.0*).

Table 2.0 - Factory Default Schedule

Button	Speed (RPM)	Duration (Hours)
STEP 1	3100	4
STEP 2	2600	4
STEP 3	1600	8
OVERRIDE	3450	2

Start Up Guide - continued

NOTE: Motor will always run the PRIMING sequence when starting from the OFF position, except when starting in OVERRIDE. The factory priming settings are 2600 RPM for 3 minutes.

6. (Self Priming Pump) Open the filter pressure relief valve until all air has escaped and then close.
7. If the pump does not prime and all instructions to this point have been followed, check for a suction leak. Repeat steps 2-7.
8. For technical assistance, call Technical Support at (800) 223-8538.

NOTE: If power goes off to the motor and the user did not press the STOP key, then the motor will automatically start and run the programmed schedule. This will ensure that the motor will re-start in the case of a power outage.

Energy Savings Optimization

The speed and duration can be programmed on site for each specific pool installation to support specific pool parameters and equipment.

In order to maximize Energy Savings from pump operation, follow the steps below to optimize the pool pump speeds to take full advantage of these savings opportunities.

1. Push the OVERRIDE button directly from the pump control, adjust the pump speed to determine the proper operation rpm of the pump for each device intended for use on the pool (filter, vacuum, HPPH, gas pool heater, etc.).
2. Use the UP (+) or DOWN (-) buttons on the pump control to increase/decrease the pump speed while in the OVERRIDE mode (*NOTE: The light over the OVERRIDE button will be lit when in OVERRIDE mode*).
3. Record the lowest RPM that allows each pool device to work properly and save for future reference and use later in these instructions.
4. STEP 1 is primarily used to circulate the pump for a sufficient period each day to ensure proper turn over of the pool water and filtration. Adjust the pump speed and duration for STEP 1 as determined for proper operation of the filtration system (proper number of turns per day).
5. STEP 2 and STEP 3 can be used and set for other equipment operation.
6. Once all pump speeds have been determined, you can adjust the programs in the pump accordingly, *See the Programming Section on page 13.*

NOTE: It is best to use a speed slightly above the minimum speed determined in the steps above to ensure proper operation under dirty filter or clogged strainer baskets, etc. Example, if the heater operation requires a setting of 1600 RPM - use 1850 RPM. This still maximizes pump energy cost savings, but also reduces the probability of nuisance issues with the pool equipment not operating properly because of insufficient water flow.

Programming

The pump operates on a 24 hour cycle that begins from the time the START button is pushed. To start the cycle at a specific time, *See the Schedule Advance Section on page 16.*

Programming - continued

Programmable Speed Settings:

3450, 3100, 2850, 2600, 2350, 2100, 1850, 1600, 1350, 1100, 850, 600, 0

NOTE: 0 is a programmable speed (RPM) and can be set for a specific duration.

Programmable Duration Settings (Hours)

24, 22, 20, 18, 16, 14, 12, 10, 8, 6, 4, 2, 0

*NOTE: Up to three (3) separate speeds with duration may be set. The sum of the three (3) durations combined **must not exceed** 24 hours. If the three combined exceed 24 hours, the pump will keep the current step and re-write the remaining two steps to zero.*

User can change the program duration and speed of STEP 1, STEP 2, STEP 3 & OVERRIDE keys.

*NOTE: Pump must be **OFF** for programming speed and duration of the STEP 1, 2, 3 keys. Override speed and duration can be programmed when the motor is **either** OFF or running.*

Four (4) programmable buttons lay across the top of the Keypad (See Figure 4 - shows the speed being set at 3100 RPM). The LED directly above each button when lit indicates it is in operation or active. To create a custom schedule and change the factory defaults settings, follow these steps:

1. Place the pump in the stop position (Press STOP Button).
2. Press the STEP 1 button. The LED above it will illuminate. The LED above the SPEED column will illuminate.
3. Using the UP (+) or DOWN (-) arrows, toggle to the desired speed. The Bar graph will show the setting as you toggle up and down (See Figure 4 - shows the speed being set at 3100 RPM).
4. Press the STEP 1 button again. The LED above the duration column will be lit.
5. Using the UP (+) or DOWN (-) arrows, toggle to the desired duration that you want this speed to run in hours. The Bar graph will show the setting as you toggle up and down (See Figure 5 - shows the duration being set at 10 hours).
6. Press any of the other STEP or the OVERRIDE button to save these settings for STEP 1.
7. To exit the system and not save these settings, press the STOP button.
8. Press STEP 2, STEP 3, or OVERRIDE key. Repeat steps 3-6 to program the corresponding speed and duration for each button.

Programming - continued

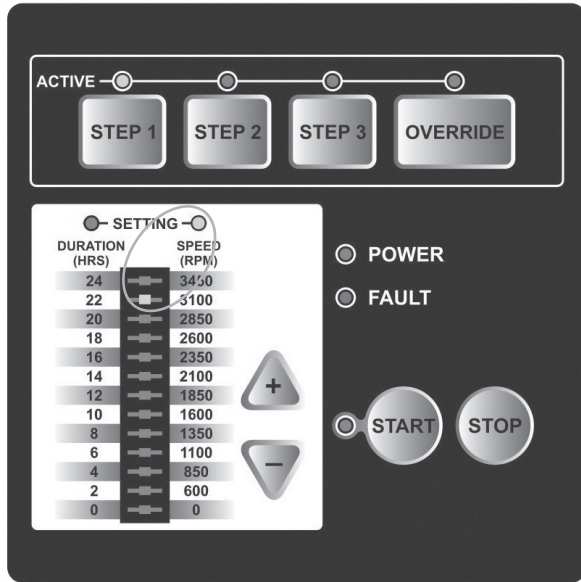

Figure 4

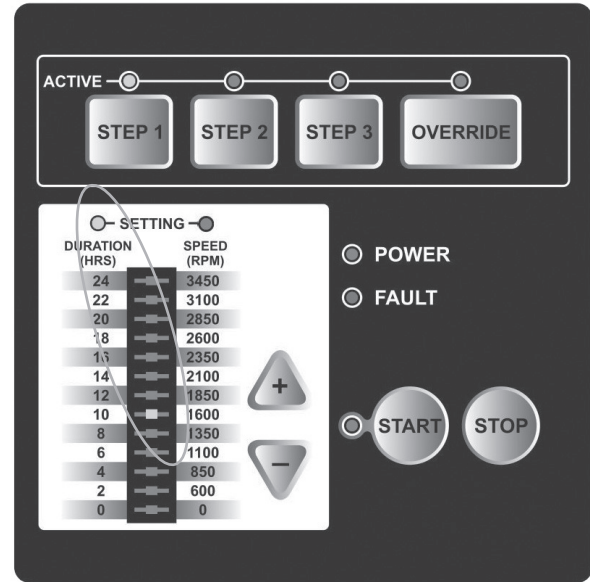

Figure 5

Restore Factory Defaults:

Press and hold the STOP and OVERRIDE key for 3 seconds. When the reset has been recognized the Bar graph will blink three times.

Menu Structure

1. STEP 1 (**Set Schedule**)
 - a. Speed and Duration
2. STEP 2 (**Set Schedule**)
 - a. Speed and Duration
3. STEP 3 (**Set Schedule**)
 - a. Speed and Duration
4. OVERRIDE (**Settings**)
 - a. Speed and Duration
5. START

Press START to run the pump based on the programmed 24 hour schedule. The schedule is based on a 24 hour cycle and will repeat each day of the week.

During operation the LED lights above the "SPEED" and "DURATION" will flip back and forth every three seconds. When lit, the graph below will show the active programmed speed or duration in progress.

NOTE: The START button must be pressed for the pump to operate. The START LED will illuminate after the button has been pressed.

NOTE: If the schedule times combined are less than 24 hours, the remaining time for the 24 hour cycle will be filled with the motor stopped.

Menu Structure - continued

Schedule Table

Use these tables to enter a personalized operating schedule. By writing down the planned schedule, it will make the programming process easier and will help the user to remember the user's settings in case the programming is inadvertently lost. The User Interface will not allow the user to program an overlap between different steps of the schedule. The STEP currently being set will always take priority of any older settings. Therefore, the duration for the other two (2) STEPs not currently being set will be cleared to 0 hours and have to be programmed again by the user. It is always a good idea to double check your programmed settings once you have completed the programming process.

Setup #1				
	STEP 1	STEP 2	STEP 3	OVERRIDE
Speed (RPM)				
Duration (Hours)				

Keypad Lock

The **Keypad** has a "key lockout" feature to prevent unwanted changes to the settings. To lock the keys, hold down the STEP 1, 2, and 3 buttons **all** at the same time for more than 3 seconds. The "active step LEDs" for STEP 1, 2 and 3 will blink for 30 seconds indicating that the keypad is locked (See Figure 6).

The user can unlock the keys by holding down the same buttons for more than 3 seconds. The "active step LEDs" for STEP 1, 2 and 3 will illuminate continuously indicating the keypad is unlocked.

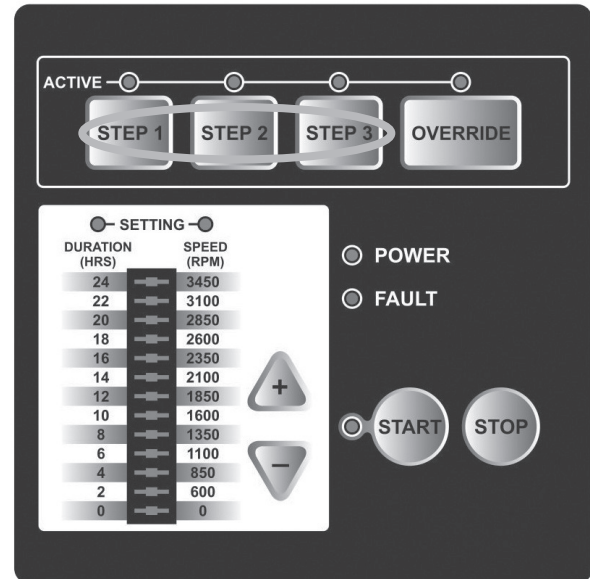

Figure 6

Motor Pause

Allows for temporary stoppage of pump without disrupting the 24 hr. schedule.

1. Press and hold the START button for three seconds while the motor is running. The motor will turn off and the START and OVERRIDE LED's will blink. Once every second indicating that the "motor pause" feature is enabled.
2. To resume running, hold the START button for three seconds.

Power Outage

If there is a power outage and the user does not press the STOP key, upon power being restored, the pump will automatically start and run the schedule starting with STEP 1. This feature ensures that the motor will re-start in the event of a power outage. The Priming sequence precedes STEP 1. All programming is retained.

Schedule Advance

The Schedule Advance Feature allows you to program the pump yet start the 24 hour cycle at a different time of day.

The following steps should be followed to set the Schedule Advance:

1. With the motor stopped, press the START Key and hold for more than three seconds. The Start LED will blink. The Duration LED and Bar Graph will illuminate.
2. Press the UP (+) or DOWN (-) arrows to set the desired schedule cycle start time. The schedule advance mode will automatically start after the desired delay time is selected. This mode can be cancelled by pressing the STOP key.

NOTE: During the Schedule Advance if a user presses the STEP 1, STEP 2, STEP 3, OVERRIDE, or the START key, the system will start the normal schedule and the Schedule Advance will be cancelled.

NOTE: If power is lost during the Schedule Advance, then the 24 hour schedule will automatically start when power is restored.

Using an Existing or New 24 hour timer to start the pump controller program

The Badu EcoM3 V (1.65) operates on a 24 hour cycle. Once the controller is programmed, it only requires the START button to be pressed to start the 24 hour cycle. Once the START button is pressed, power cycled (such as a temporary power failure) to the pump would result in the 24 hour cycle restarting at the beginning of STEP 1. Using or adding a "24 hour timer" will allow you to start the "24 hour cycle" at any time during the day.

NOTE: The pump must be programmed and the Start Key pressed in order to operate.

Optional Controller

This optional controller uses the RS485 connectors (See Table 3.0).

NOTE: Verify that Dip switch 1 is ON and Dip switch 5 is OFF.

NOTE: The +12V and GND can also be used to supply 12V for the Digital Inputs when Dip switch 1 is ON.

The benefits of the optional remote controller:

1. Ability to view fault-codes and troubleshoot.
2. Ability to set a pump running schedule based on a real-time clock setting.
3. Ability to remotely mount.
4. Ability to configure Prime Speed and Prime Duration.
5. Ability to configure Freeze Protection temperature.
6. Ability to view speed and power of the motor in real-time.
7. Ability to adjust motor speed in 25 RPM increments.
8. Battery backup to keep stored settings and time.

Freeze Protection

Freeze Protection will run the motor at 2600 RPM for eight (8) hours if the ambient temperature drops below 39° F. Once this eight (8) hour duration has elapsed, the motor control will check the ambient temperature again. If the temperature is still below the 39° F threshold, the motor will run for an additional eight (8) hours. If the temperature is above the threshold, the motor will **automatically** return to the 24 hour based schedule.

*NOTE: The freeze protection function will **NOT** operate if the START button is not pressed. This can be confirmed by verifying that the START LED is illuminated.*

Override

The pump is equipped with an OVERRIDE feature, which can be engaged to temporarily run at higher or lower speeds between 600 to 3450 RPM. Once override duration has elapsed, the motor will automatically return to programmed schedule.

1. Pressing the OVERRIDE key; while the motor is running; will cause the motor to start running in the OVERRIDE mode at the programmed Speed and Duration. The “active step LED” for OVERRIDE will illuminate. The speed and duration settings LED along with its respective bar graph LED of OVERRIDE shall blink back and forth at three (3) seconds.

2. The UP (+) / DOWN (-) arrows allow the user to configure Speed and Duration. These settings can be changed while the motor is **running**. These settings are stored each time the UP (+) / DOWN (-) arrows are pressed.

*NOTE: When the OVERRIDE duration ends, the motor resumes the 24 hour duration cycle and will start in the corresponding STEP. The OVERRIDE duration will **not** affect the start or stop times of the 24 hour cycle.*

NOTE: Pressing/Holding OVERRIDE key for more than three (3) seconds will cancel OVERRIDE mode.

NOTE: During the OVERRIDE mode, the motor will not start with the priming sequence.

NOTE: Pressing STOP at any time turns the motor OFF and clears the start time for the 24 hour schedule.

Communication

Control with Digital Inputs

The user can run the motor at the programmed STEP 1, 2, 3, or OVERRIDE speeds by utilizing the four (4) digital inputs. STEP 1, 2, 3, or OVERRIDE are equivalent to Digital Input 1, 2, 3, or 4 respectively.

The controller is rated to accept digital inputs of 18V-30V AC (24V AC +/- 20%) and 9-30V DC (12/24 V DC +/- 20%).

NOTE: The motor will detect either a 50/60Hz for AC input or an active low signal for DC digital inputs.

The items below describe the functionality of the digital inputs: (See Figure 7)

1. If the user provides any one of the 4 digital inputs, then the DURATION LED will blink every one (1) second to indicate the Digital Input is functioning properly.

2. The motor will illuminate the corresponding “active step LED” and the respective bar graph LED. The START LED will be OFF when a digital input is present.

NOTE: There is no schedule for digital inputs. The timing for each speed is controlled directly by the digital inputs.

Communication - continued

NOTE: The digital inputs have the highest priority amongst all the inputs (i.e. Keypad, Serial and Digital Inputs). Therefore, the serial commands as well as the Overlay Keypad inputs will be ignored when a digital input is present.

NOTE: If more than one digital input (switch) is present, then the motor will give priority to the highest number digital input. Therefore, OVERRIDE has highest priority followed by STEP 3, then STEP 2, then STEP 1.

NOTE: If no digital input is detected, the motor will automatically start the 24 hour schedule if the START key was pressed prior to the application of the digital input.

NOTE: If using external devices it is the users responsibility to verify appropriate power and speed conditions. Refer to the proper external device manual.

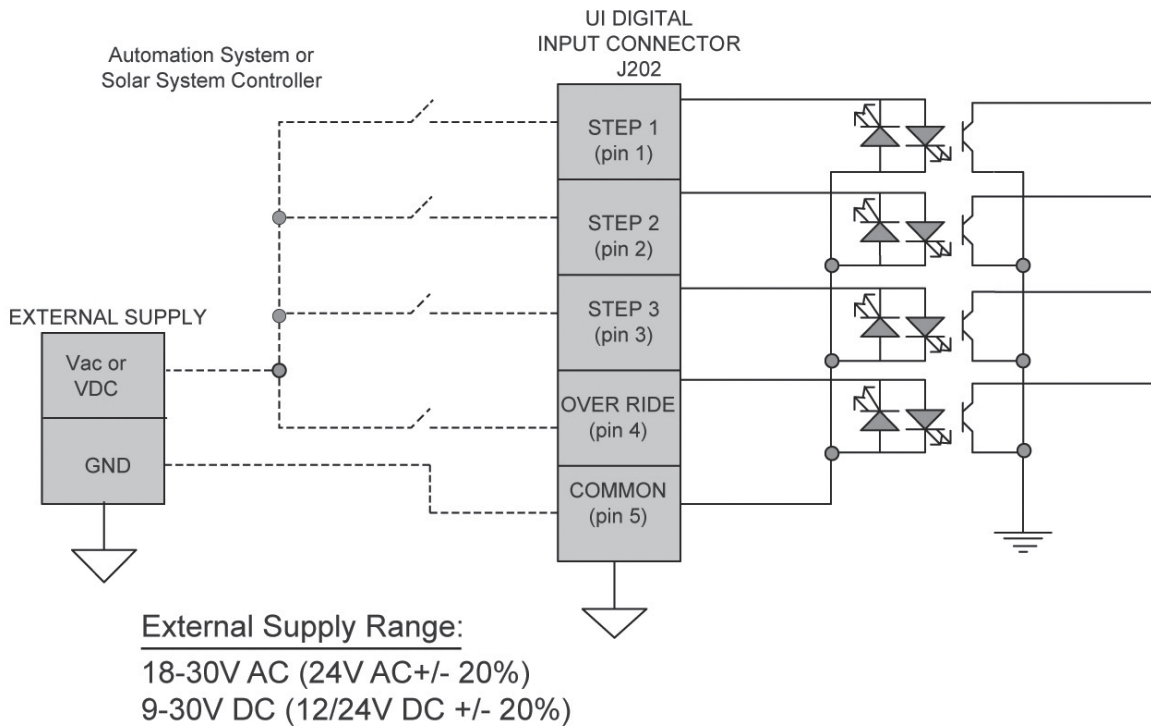

Figure 7

Table 3.0 - Communication Connection Table (RS485)

Pin#	Wire Color	Description
J201-1	Red	+ 12V
J201-2	Green	RS485 - A
J201-3	Black	RS485 - B
J201-4	Yellow	Isolated Ground

3rd Party Controllers (Wiring)

Wiring Diagram for ProLogic & Badu EcoM3 V (1.65)

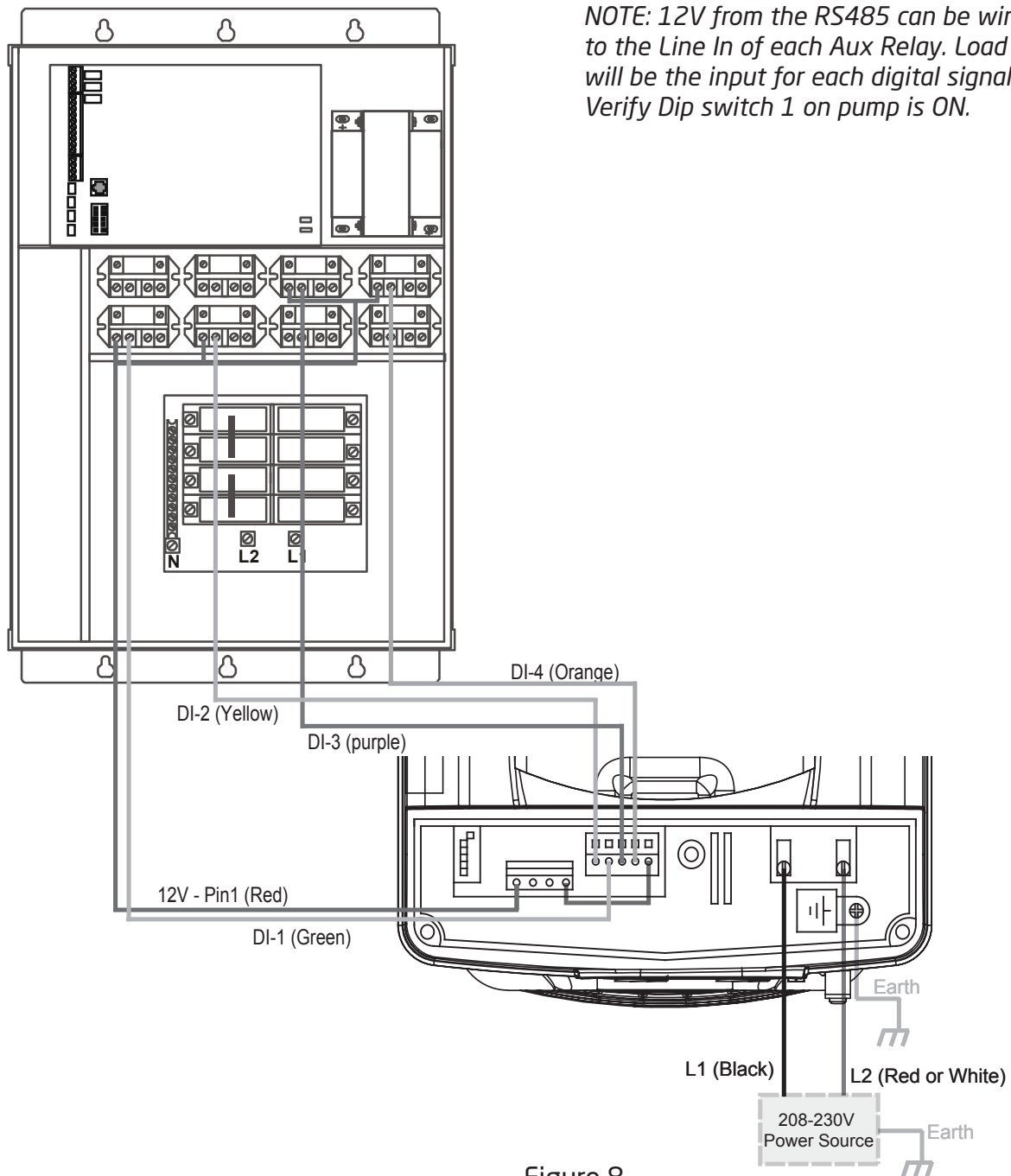
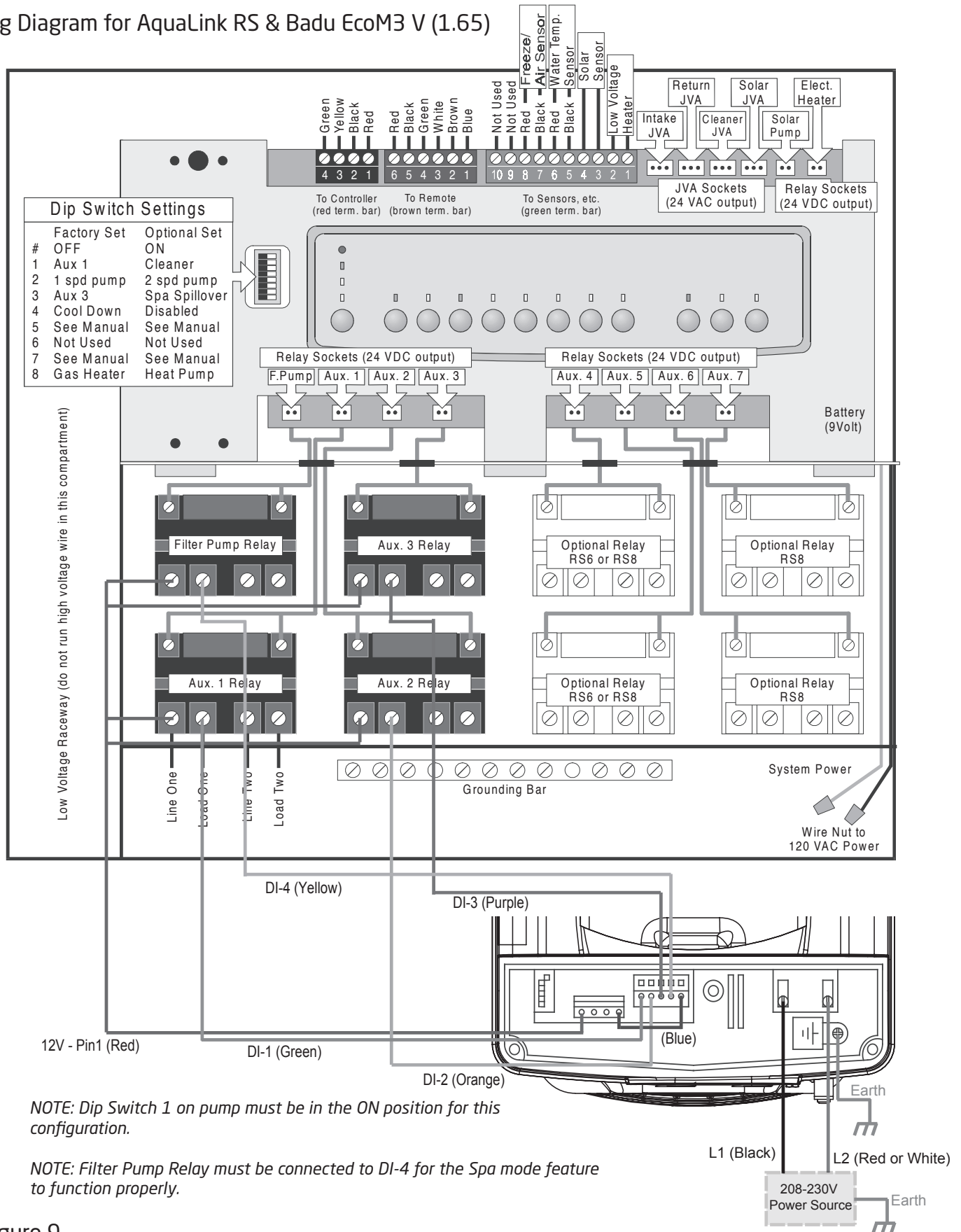

Figure 8

3rd Party Controllers (Wiring) - continued

Wiring Diagram for AquaLink RS & Badu EcoM3 V (1.65)



NOTE: Dip Switch 1 on pump must be in the ON position for this configuration.

NOTE: Filter Pump Relay must be connected to DI-4 for the Spa mode feature to function properly.

Figure 9

3rd Party Controllers (Wiring) - continued

Wiring Diagram for Multiwave & Badu EcoM3 V (1.65)

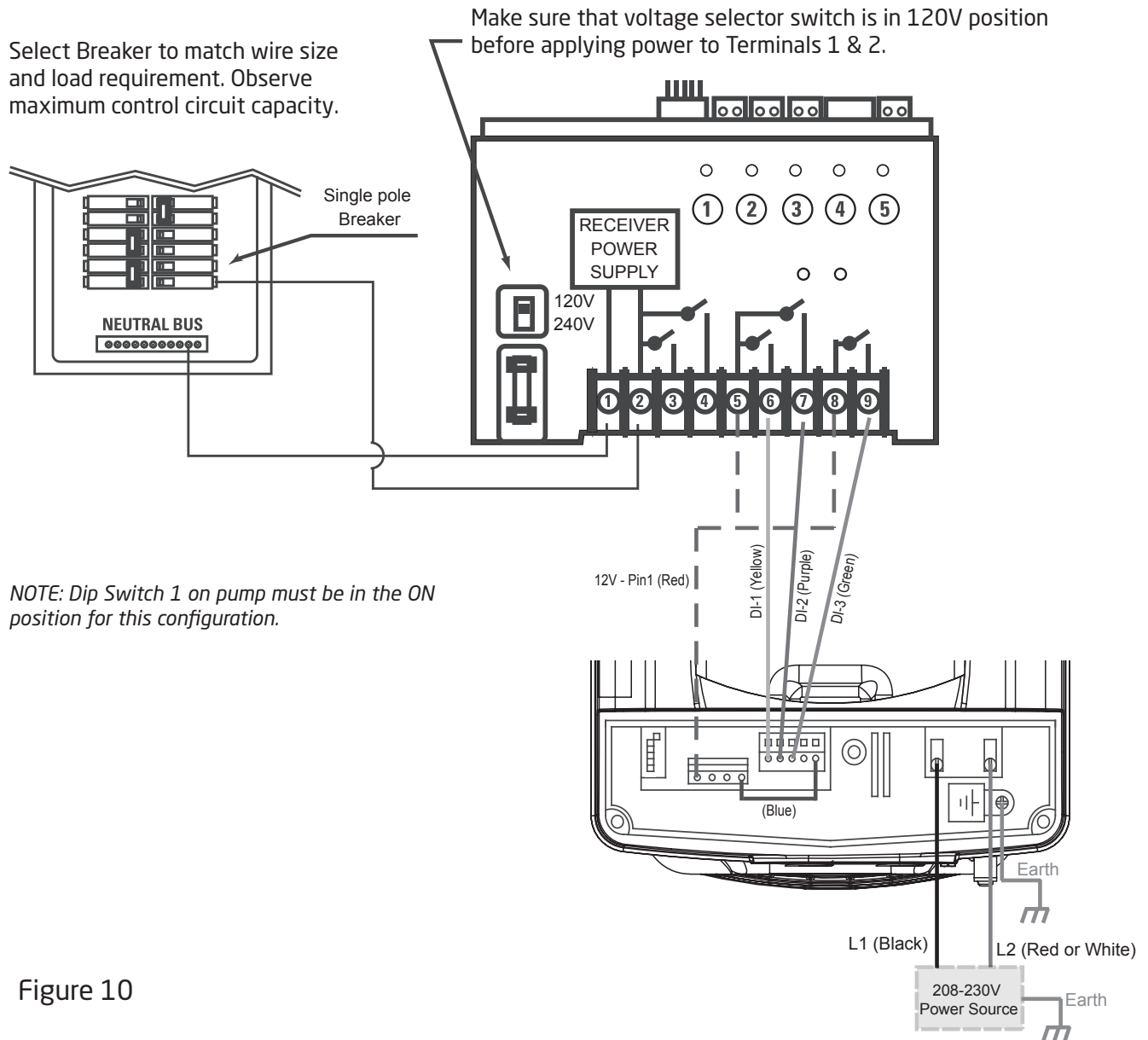
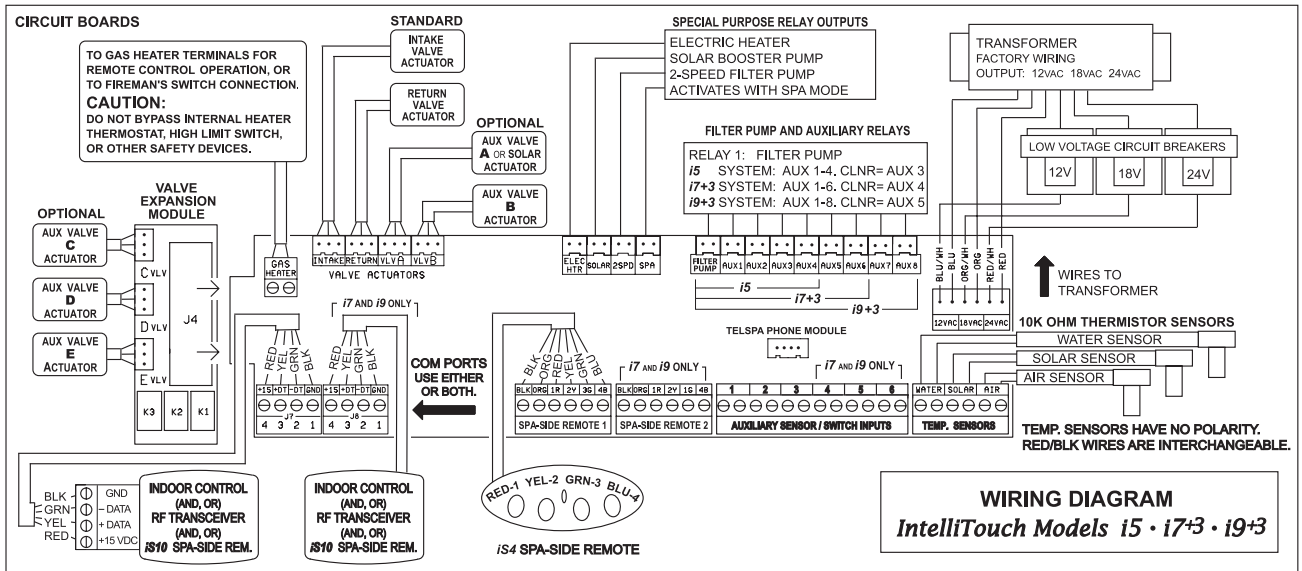

Figure 10

3rd Party Controllers (Wiring) - continued

Wiring Diagram for IntelliTouch & Badu EcoM3 V (1.65)



WIRING DIAGRAM
IntelliTouch Models i5 • i7+3 • i9+3

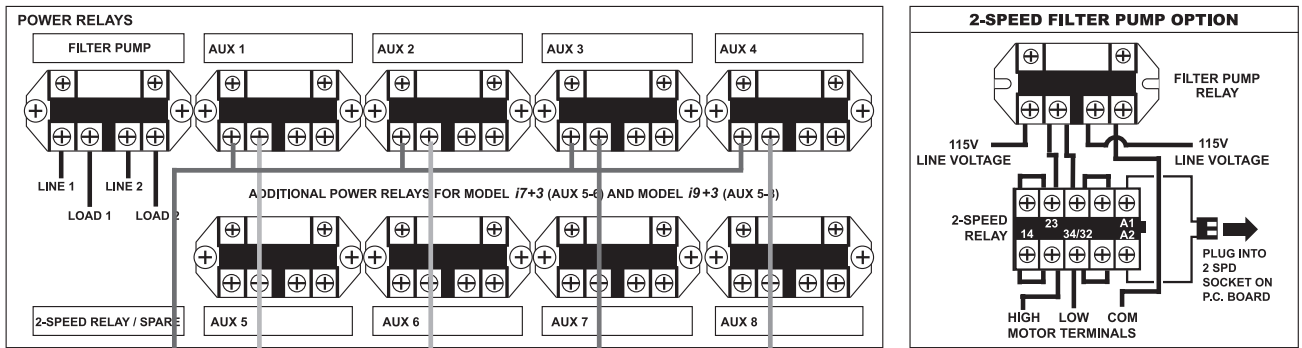

NOTE: Dip Switch 1 on pump must be in the ON position for this configuration.

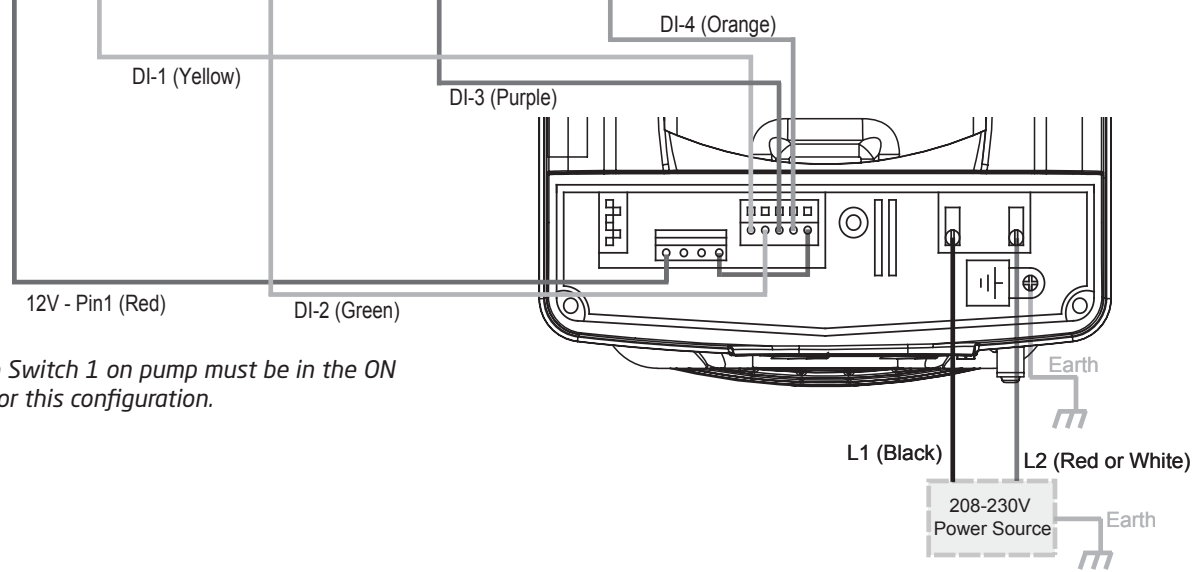

Figure 11

Heat Pump Pool Heater Connections (Wiring)

The Badu EcoM3V (1.65) can be connected directly to a single phase or 3-phase Raypak, Rheem, Ruud, Weatherking, and Perfecttemp Heat Pump Pool Heater (HPPH) without the need for any external sequencer or control. The HPPHs will provide an OVERRIDE signal to the pump whenever there is a Call for Heat at the HPPH if wired as shown in these instructions (See Figures 12, 13, and 14). The pump will continue to operate at this OVERRIDE speed until the HPPH thermostat has been satisfied.

NOTE: For heaters other than those listed, please consult the heater manufacturer for direct wiring compatibility with the Badu EcoM3 V (1.65)

Digital HPPH Wiring Connections:

Field wiring to Digital HPPH products will be accomplished by connecting directly to the HPPH control board as shown below in Figure 13. A 1/4" spade connection is required to connect to the HPPH control board at the terminals marked "PUMP" as noted below. Use 18 AWG insulated stranded wire for these connections.

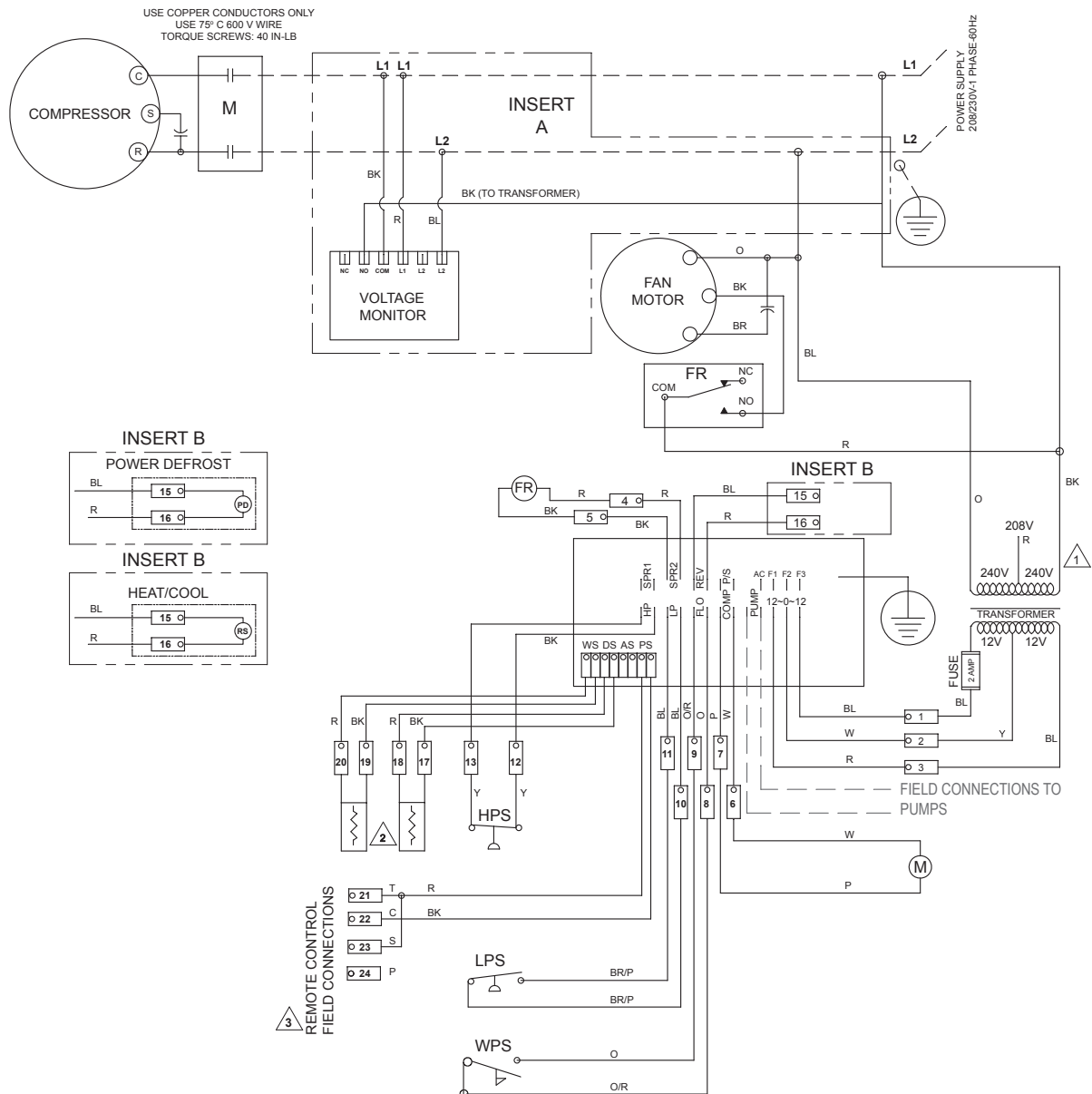

Figure 12 - Digital HPPH Wiring Connections

Heat Pump Pool Heater Connections (Wiring) - continued

Analog HPPH Wiring Connections

Field wiring to Analog HPPH products will be accomplished by connecting directly to terminals #15 and #16 on the terminal strip located in the HPPH junction box as shown below in Figure 14. Use 18 AWG insulated stranded wire for these connections.

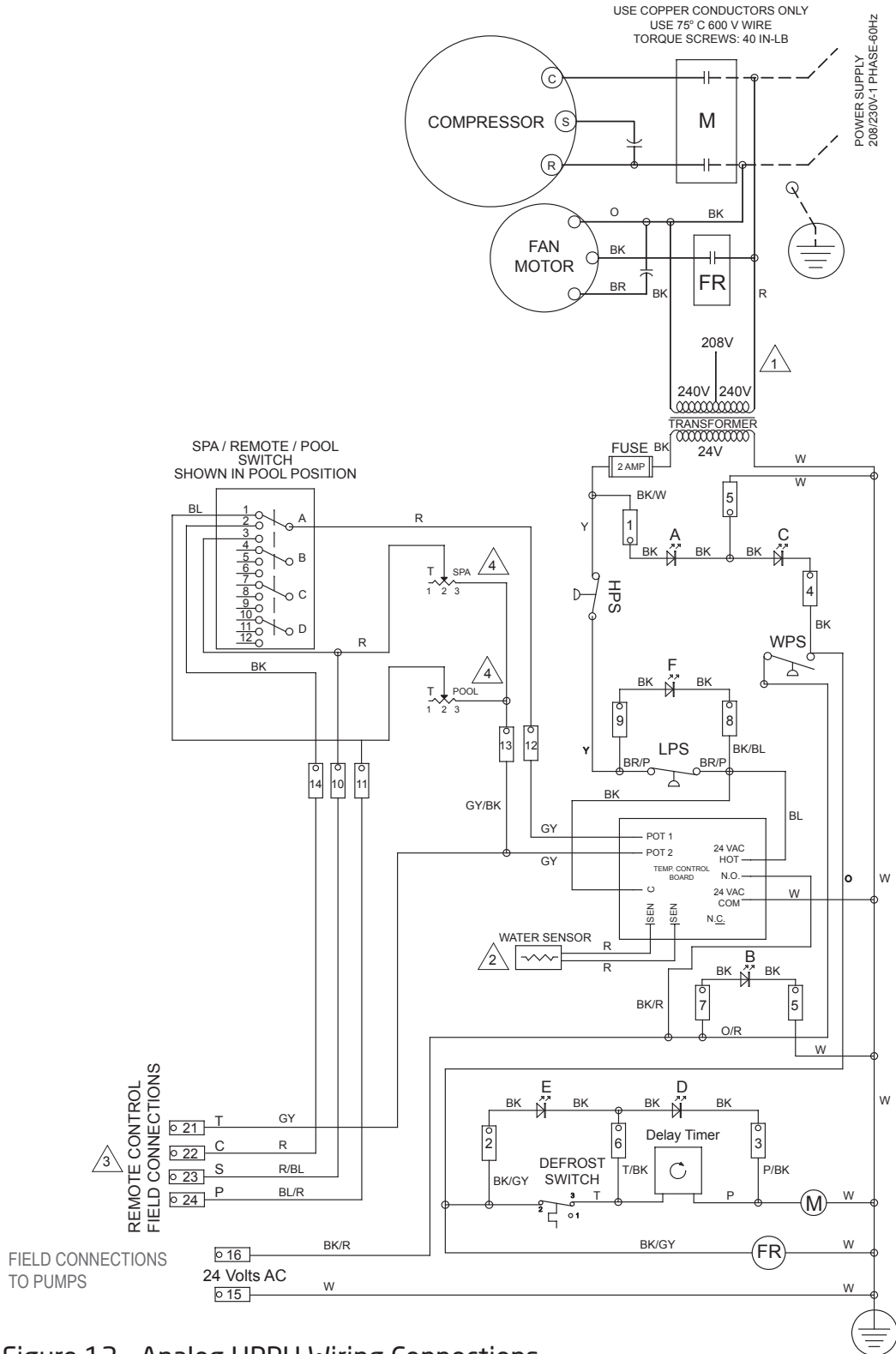

Figure 13 - Analog HPPH Wiring Connections

Heat Pump Pool Heater Connections (Wiring) - continued

Wiring Connections to the the Badu EcoM3 V (1.65) Pump

Connect the 18AWG wires from the HPPH to the Badu EcoM3 V (1.65) pump as show and described below.

It does not matter which wire is connected to the IO-4 terminal or the IGND terminal for these 24 VAC connections. While the 24 VAC connections are polarity sensitive, the digital inputs on the VSP pump are floating and look for a differential voltage from IO-4 to IGND. Therefore, the wiring does not matter for an AC input signal, but will matter for a DC input signal. However, connections to the Analog and Digital HPPH are 24 VAC signals and so this is not an issue.

The factory default speed setting for this OVERRIDE signal is 3450 RPM. This is to ensure sufficient water flow to ensure proper operation of the HPPH. If optimization of this pump speed is desired as an energy savings measure (*Refer to the Energy Savings Operation - Pump Speed Optimization Section page 12*).

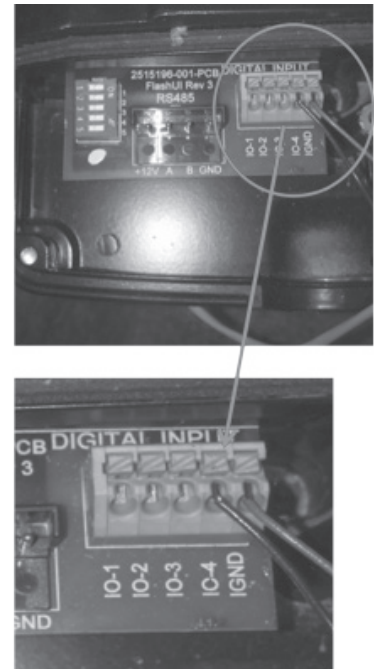

Figure 14 - Wiring Connections

5 Service and Maintenance

Routine Maintenance

This pump requires little or no service other than reasonable care and periodic cleaning of the strainer basket.

1. Inspect the pump basket for debris by looking through the clear pump lid.
2. Turn OFF the power to the pump. If the pump is located below the water level, close isolation valves on the suction and discharge sides of the pump to prevent back flow of water.
3. Remove any debris, because as the debris accumulates, it will begin to block the flow of water through the pump. Keep the basket clean and clear to improve the performance of the pump.
4. Turn the lid's lock ring counter clockwise until it stops. Carefully remove the lid and lock ring.
5. Remove the basket and properly dispose of the debris into the trash and rinse out the basket. Check basket for cracks, if crack is found replace basket.
6. Replace basket back into the pump, align the basket properly with the suction pipe. Then fill with water up to the suction pipe. Clean clear cover, lid o-ring and sealing surface of the pump of any debris.
7. Replace lid with locking ring. *Hand-tighten* the lid to make an air-tight seal. ***DO NOT use any tools to tighten the lid.***

Routine Maintenance - continued

8. Verify that all valves have been returned to the proper position for normal operation. Turn on the power to the pump.

Winterizing

CAUTION: *The pump must be protected when freezing temperatures are expected. Allowing the pump to freeze will cause severe damage and void the warranty.*

There are two options when winterizing the pump

Option 1:

1. Drain all the water from the pump, system equipment, and piping.
2. Remove drain plugs. Do not replace plugs. Store the plugs in the empty strainer basket for winter.
3. Keep the motor covered and dry.

Option 2:

1. Drain all the water from the pump, system equipment, and piping.
2. Remove the pump and motor from the plumbing and store indoors in a warm and dry location.

NOTE: When the winter season is over the pump will need to be primed prior to start (Refer to Section 4 Operation, Start Up Guide).

CAUTION: DO NOT run the pump dry. If the pump is run dry, the mechanical seal will be damaged and the pump will start to leak at the seal. If this occurs, the mechanical seal will need to be replaced. **ALWAYS** maintain the proper water level in your pool. Continued operation in this manner could cause a loss of pressure, resulting in damage to the pump casing, impeller, and mechanical seal (voiding warranty).

6 Troubleshooting

Fault LED

WARNING: *The pump must be serviced by a professional service technician qualified in pool/spa installation. The following procedures must be followed exactly. Improper installation and/or operation can create dangerous electrical hazards, which can cause high voltage to run through the electrical system. This can cause property damage, serious personal injury, and/or death. Improper installation and/or operation will void the warranty.*

The fault LED will be solidly on if there is a fault in the controller portion of the electronics. This can include over temperature, over current, over/under voltage, or an open phase of the motor. The fault LED will blink if a fault has been detected in the user interface. The motor reads the fault status every seven seconds. The motor will stop and remain off when a fault is present. Once the fault is cleared, if the motor was previously running, it will automatically resume running the normal schedule. During the fault condition, the Bar graph LEDs will turn off. However, the power LED and active STEP LED will remain illuminated. When a fault is present, only the STOP key will function. Once the fault is cleared, the fault LED will turn off automatically.

General Pump Troubleshooting

Problem	Possible Cause	Solution
1. Pump will not prime.	<p>A. Suction air leak</p> <p>B. No water in pump.</p> <p>C. Closed valves or blocked lines.</p> <p>D. Low voltage to motor.</p>	<p>Make sure see-through lid and o-rings are clean and properly positioned. Hand tighten see-through lid. Tighten all pipes and fittings on suction side of pump. Be sure water in pool is high enough to flow through skimmer.</p> <p>Make sure strainer tank is full of water.</p> <p>Open all valves in system. Clean skimmer and strainer tank. Open pump and check for clogging of impeller.</p> <p>Check voltage at motor. If low, pump will not come up to speed.</p>
2. Motor Fails to Start	<p>A. No power to motor.</p> <p>B. Pump jammed</p> <p>C. Controller Dip switches not configured properly</p>	<p>Check that all power switches are on. Be sure fuse or circuit breaker is properly set. Time set properly? Check motor wiring at terminal.</p> <p>With power off, turn shaft. It should spin freely. If not, disassemble and repair.</p> <p>Verify that the Dip switches are in the correct position.</p>
3. Motor Runs then Stops	<p>A. Over temperature fault</p> <p>B. Over current fault</p>	<p>Check the back of the motor is free from dirt and debris.</p> <p>Motor will automatically restart after one minute.</p>
4. Motor is noisy	<p>A. Debris in contact with fan</p> <p>B. Debris in strainer basket</p> <p>C. Loose mounting</p>	<p>Check that the back of the motor is free from dirt and debris.</p> <p>Clean strainer basket.</p> <p>Check that the mounting bolts are tight.</p>
5. Low flow	<p>A. Dirty filter</p> <p>B. Suction Leak</p>	<p>Back wash filter when filter pressure is high, or clean cartridges.</p> <p>See Problem 1</p>

Blocked Impeller

WARNING: Before servicing the pump, switch off the circuit breakers at the power source. Severe personal injury or death may occur if the pump starts while your hand is inside the pump.

1. Turn OFF the pump. Switch OFF the circuit breaker to the pump motor.
2. Remove the pump lid and strainer basket.
3. Look inside pump for debris. Remove any debris found inside.

Blocked Impeller - continued

4. Replace the strainer basket and lid.
5. Switch on the circuit breaker to the pump motor.
6. Turn on the pump, see if the problem is resolved.
7. If the impeller is still blocked with debris and it is not possible to remove the debris using Steps 2 - 4, the pump will need to be disassembled in order to access the inlet and outlet of the impeller.

Removal and Replacement of the Impeller and/or Mechanical Seal

WARNING: Before servicing the pump, switch off the circuit breakers at the power source. Severe personal injury or death may occur if the pump starts while your hand is inside the pump.

1. Turn off the pump. Switch off the circuit breaker to the pump motor. If you are not replacing the motor, **DO NOT** disconnect the electrical wiring.
2. Turn off any valves to prevent pool water from reaching the pump. Drain water from the pump by loosening the unions or removing the drain plugs.
3. Remove the eight (8) screws connecting the pump casing to the flange.
4. Pull the motor, seal housing, flange out from the pump casing. Remove the pump casing o-ring. The impeller is connected to the motor shaft.
5. Remove the diffuser by gently pulling the diffuser (the diffuser is the cover over the impeller) horizontally until the pins clear the seal housing.
6. Place a 5/16" Allen head wrench through the center hole of the fan cover and into the recess on the end of motor shaft.
7. While holding the motor shaft, turn the impeller counter-clockwise.

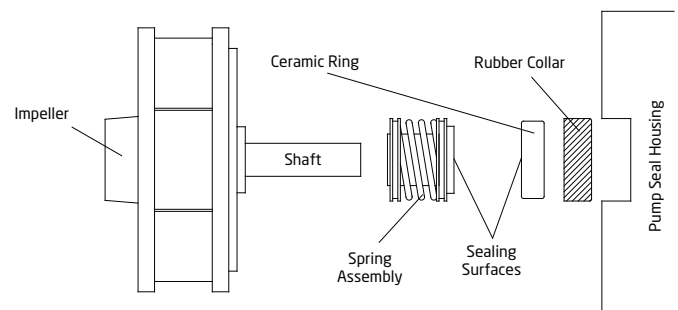

Figure 15

8. Gently pull the mechanical seal from the impeller shaft noting the way it was originally installed.

CAUTION: DO NOT damage the ceramic or carbon surfaces of the seal. If the surfaces are damaged, leaks will occur.

9. Using water with a small amount of dish soap, brush the impeller shaft for ease of assembly.
10. With the carbon side up, push the mechanical seal onto the impeller shaft and wipe carbon surface with a clean cloth.

CAUTION: DO NOT use grease or lube to install seal. It will damage the seal and cause failure.

11. The ceramic side of the seal can be pushed out from the rear of the seal housing. (Make note of its position before removing.)

Removal and Replacement of the Impeller and/or Mechanical Seal - continued

12. Using water only, wet the ceramic side of the seal and using your thumbs push into the seal housing. Clean surface with a clean cloth.
13. Wipe the motor shaft of all debris. Re-install the seal housing and apply a single drop of Loctite to the motor shaft threads.
14. Install impeller by spinning it clockwise onto the motor shaft. Continue to turn clockwise until the carbon and ceramic sides make contact and the seal spring slightly compresses.
15. Install the diffuser by aligning the diffuser pin with the holes in the seal housing and pressing together.
16. Make sure the diffuser and casing o-rings are in place and free of debris. Reassemble in reverse, sliding the seal housing back into the casing.
17. Tighten (torque of 5 Nm or 44.2 in-lb.) the eight (8) screws using a cross pattern from side to side and top to bottom.

CAUTION: ***DO NOT** over-tighten or you will strip the casing threads.*

Motor Replacement

WARNING: *The pump must be serviced by a professional service technician qualified in pool/spa installation. The following procedures must be followed exactly. Improper installation and/or operation can create dangerous electrical hazards, which can cause high voltage to run through the electrical system. This can cause property damage, serious personal injury, and/or death. Improper installation and/or operation will void the warranty.*

1. Disconnect the wiring from the side of the motor. *(Refer to the Electrical Installation page 9-10.)*
2. Remove the eight (8) screws holding the flange to the pump casing.
3. Slide the motor and flange from the casing.
4. Remove the diffuser by gently pulling the diffuser horizontally until the pins are clear from the seal housing.
5. Place a 5/16" Allen head wrench through the center hole of the fan cover and into the recess on the end of the motor shaft.
6. While holding the motor shaft, turn the impeller counter-clockwise.
7. After removal of the impeller, the seal housing will slide easily off the motor shaft.
8. Using a 9/16" wrench, remove the four bolts and washers securing the flange to the motor.
9. Remove the motor flanges from the face of the old motor and install on the new motor.
10. Clean the surfaces of the seal *(Refer to the Removal and Replacement of the Impeller and/or Mechanical Seal Section page 28-29 steps 9 -17)*. Reverse the process for installation.

7 Product Specifications

Dimensional Drawing

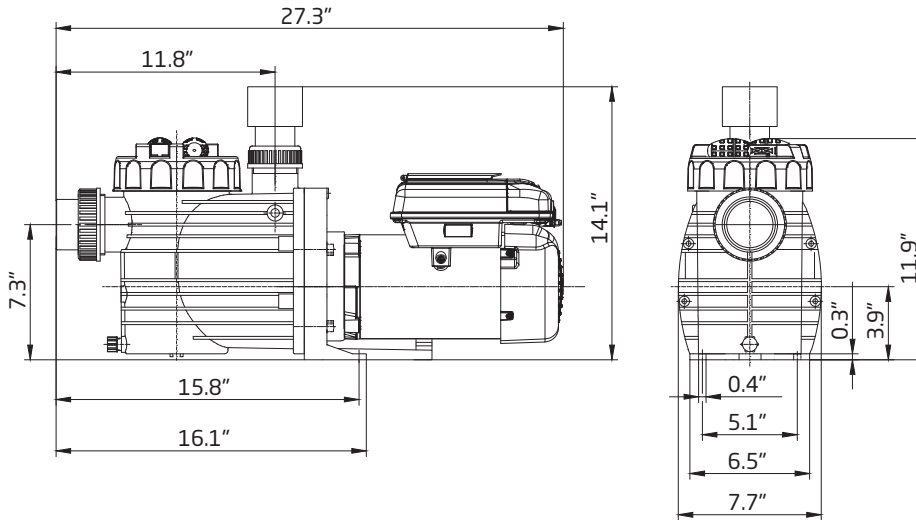

Performance Curve

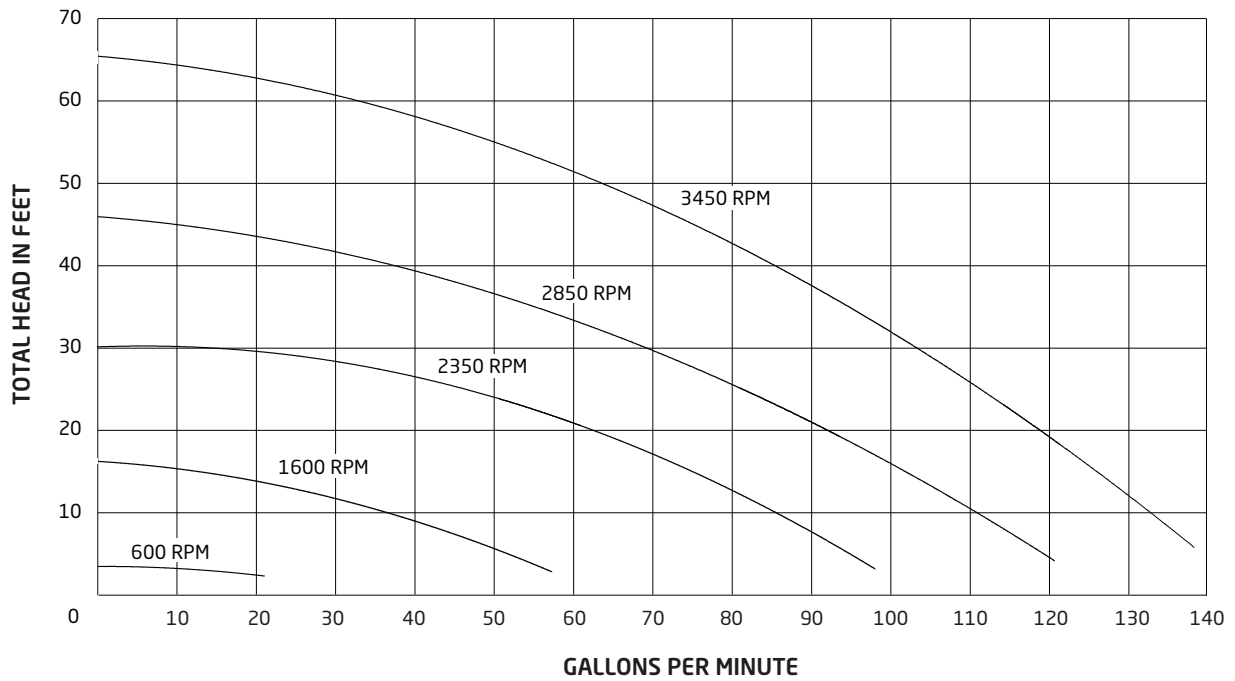

Replacement Parts and Exploded View

PART NUMBER	DRAWING NUMBER	QTY REQUIRED	DESCRIPTION
2901116010	1	1	LID - CLEAR
2921116012	NOT SHOWN	1	LID - CLEAR WITH LED LIGHT
2921116022	2	1	LOCK RING WITH HANDLES - LID
2921141210	3	1	O-RING - LID 137 x 5mm
2901114300	4	1	BASKET - ONE PIECE
2921110130	5	1	CASING
2901158200	6	1	DRAIN CAP 3/8" WITH GASKET - CASING
2920889410	7	3	LEGO SPACER
2991000091	8	8	SCREW - CASING HEX/SLOT M7 x 48mm SS
2920141210	9	1	O-RING - DIFFUSER 90 x 5mm
2921117412	10	1	DIFFUSER
2920223090	11	1	IMPELLER 101 / 9.0mm
2920343310	12	1	MECHANICAL SEAL (20mm) COMPLETE
2921141222	13	1	O-RING - CASING 190 x 6mm
2920216110	14	1	INTERMEDIATE FLANGE
2921116110	15	1	SEAL HOUSING
2921111300	16	1	FLANGE
2920110200	17	1	MOTOR FLANGE
2991400029	18	4	BOLT - MOTOR (3/8"-16 x 2.25")
2991400035	19	4	WASHER - MOTOR BOLT (3/8") SS
2921770005	24	1	SET - SUCTION UNION COMPLETE
2500300902	27	1	SET - DISCHARGE UNION COMPLETE
2500300914	24 & 27	1	COMPLETE UNION PACKAGE - SUCTION/DISCHARGE
M48AA85A01	28	1	MOTOR - VARIABLE SPEED 1.65 THP, 1 PH, 208-230V

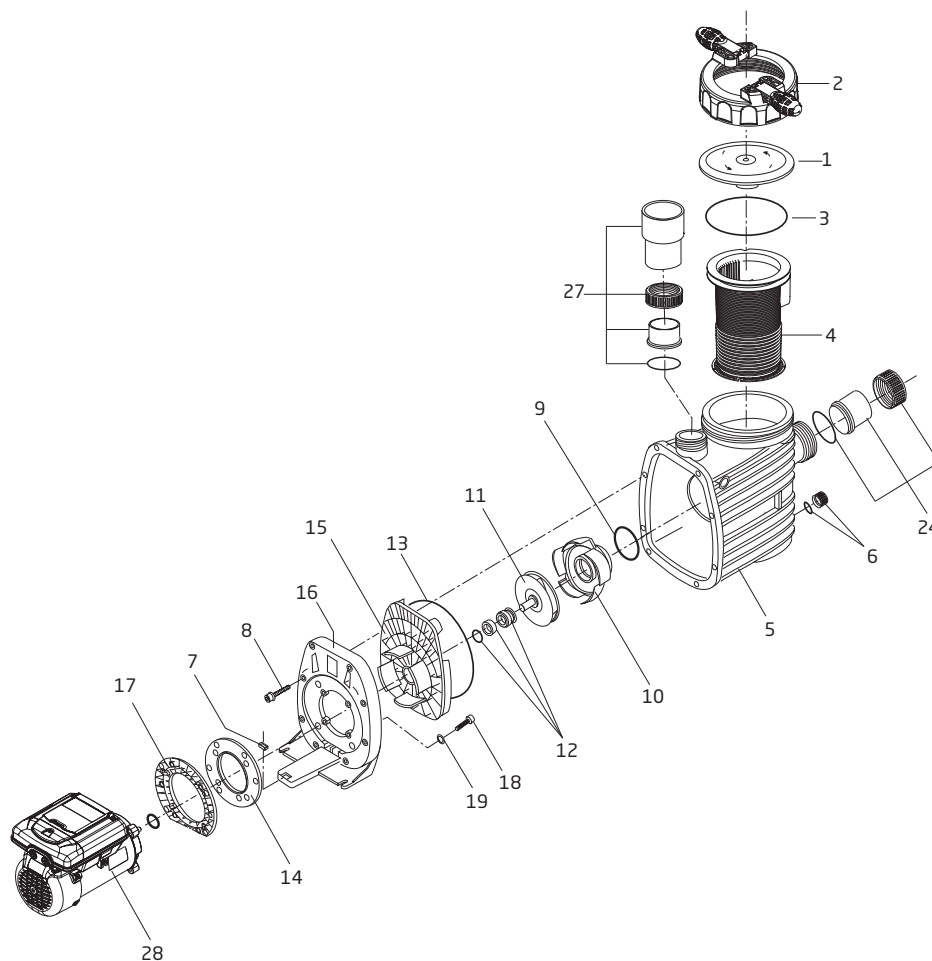

8 Limited Warranty

Speck Pumps-Pool Products, Inc. grants solely to the original consumer purchaser (“Buyer”) of the pump and motor the following personal, non-transferable and limited warranty on the following terms and conditions (the “Limited Warranty”): the pump and motor is warranted to be free of material defects in materials or workmanship under normal use for a period of two (2) year beginning on the date of the Buyer’s purchase of the pump and motor. Notwithstanding any provisions herein to the contrary, the warranties and obligations hereunder shall not in any event extend for more than three (3) years beyond the date of shipment of the pump and motor from the factory (the “Limited Warranty Period”). The Limited Warranty is subject to each of the following additional terms and conditions:

1. IN THE EVENT OF ANY BREACH OF THE LIMITED WARRANTY, SPECK PUMPS-POOL PRODUCTS, INC.’S ENTIRE OBLIGATION AND LIABILITY TO BUYER, AND BUYER’S SOLE AND EXCLUSIVE REMEDY SHALL BE AS FOLLOWS:

Speck Pumps-Pool Products, Inc. will, at its option, either repair or replace the pump and motor or refund to Buyer the purchase price actually paid by Buyer for the pump and motor subject to the Limited Warranty. Speck Pumps-Pool Products, Inc. shall have no obligations under the Limited Warranty unless Buyer delivers timely written notice to Speck Pumps-Pool Products, Inc. of the Limited Warranty claim within the Limited Warranty Period and returns the pump and motor to Speck Pumps-Pool Products, Inc. if requested. To the fullest extent permitted by law, Speck Pumps-Pool Products, Inc. expressly disclaims any liability for, and the Limited Warranty does not include or cover, any labor, costs or other expenses in connection with the removal, transportation, shipment, insurance, replacement, repair, or installation of repaired or replaced parts or for any other costs or expenses or damages to property or things including, but not limited to, those arising in connection with the use of, or inability to use, the pump and motor.

2. To the fullest extent permitted by law, the Limited Warranty will be void and of no force or effect and Speck Pumps-Pool Products, Inc. will have no liability, responsibilities or obligations to Buyer or with respect to the pump and motor in the event of the occurrence of any one or more of the following:

- (a) Any damage to the pump and motor caused by Buyer, any third party, ground movement, other natural forces, acts of God or any other sources or causes not arising from a breach of the Limited Warranty, excluding ordinary wear and tear;
- (b) Any replacement, modification, alteration or repair of any parts or components of the pump and motor by anyone other than Speck Pumps-Pool Products, Inc.;
- (c) Any abuse, misuse, accident, tampering with, improper installation or modification of the pump and motor or any other actions, inactions or failures to act that violate the terms and conditions of this Limited Warranty;
- (d) Buyer’s failure or inability to present an invoice, bill, receipt or other documentation clearly evidencing that the pump and motor was installed and maintained in strict compliance with this Limited Warranty and that the claim was timely submitted within the Limited Warranty Period; and/or
- (e) Buyer’s failure to comply with the conditions and contingencies set forth in paragraph 3 below.

3. The Limited Warranty is expressly conditioned and contingent upon Buyer’s strict compliance with each of the following:

- (a) Installation of the pump and motor by an experienced and qualified pool industry professional and a licensed electrician who is licensed within the jurisdiction in which the pump and motor is installed and will be used; and
- (b) Buyer’s operation and maintenance of the pump and motor in strict accordance with Speck Pumps-Pool Products, Inc.’s printed operator/maintenance manuals delivered with the pump and motor.

4. DISCLAIMER: THE LIMITED WARRANTY IS THE ONLY WARRANTY MADE AND IS IN LIEU OF ALL OTHER WARRANTIES, AND ANY AND ALL IMPLIED WARRANTY OR CONDITION OF MERCHANTABILITY, THE IMPLIED WARRANTY AGAINST INFRINGEMENT, AND THE IMPLIED WARRANTY OR CONDITION OF FITNESS FOR A PARTICULAR PURPOSE ARE EXPRESSLY LIMITED IN THEIR SCOPE AND DURATION TO THE ONE YEAR TERM OF THE LIMITED WARRANTY SET FORTH HEREIN. SOME STATES DO NOT ALLOW LIMITATIONS ON HOW LONG AN IMPLIED WARRANTY LASTS, SO THE ABOVE LIMITATION MAY NOT APPLY TO THE BUYER.

Limited Warranty - continued

5. TO THE FULLEST EXTENT PERMITTED BY LAW, IN NO EVENT SHALL SPECK PUMPS - POOL PRODUCTS, INC. OR ITS OFFICERS, DIRECTORS, EMPLOYEES, SHAREHOLDERS, AGENTS, OR REPRESENTATIVES BE LIABLE FOR ANY SPECIAL, INDIRECT, INCIDENTAL, EXEMPLARY OR CONSEQUENTIAL DAMAGES OR LOSS, INCLUDING TIME, MONEY, GOODWILL, AND LOST PROFITS IN ANY WAY WHICH MAY ARISE HEREUNDER OR FROM THE USE OF OR INABILITY TO USE THE PUMP AND MOTOR OR THE PERFORMANCE OR NONPERFORMANCE OF ANY OBLIGATION UNDER THIS LIMITED WARRANTY. THIS PARAGRAPH, THE WARRANTY DISCLAIMERS IN PARAGRAPH 4 ABOVE, AND THE SOLE AND EXCLUSIVE REMEDY SET FORTH IN PARAGRAPH 1 ABOVE SHALL APPLY EVEN IF SPECK PUMPS - POOL PRODUCTS, INC. HAS BEEN NOTIFIED OF THE POSSIBILITY OR LIKELIHOOD OF SUCH DAMAGES OCCURRING, WHETHER SUCH LIABILITY IS BASED ON CONTRACT, TORT, NEGLIGENCE, STRICT LIABILITY, PRODUCTS LIABILITY OR OTHERWISE, AND EVEN IF ANY REMEDY STATED HEREIN FAILS OF ITS ESSENTIAL PURPOSE. SOME STATES DO NOT ALLOW THE EXCLUSION OR LIMITATION OF SPECIAL, INDIRECT, INCIDENTAL, EXEMPLARY OR CONSEQUENTIAL DAMAGES OR LOSS, SO THE ABOVE EXCLUSIONS AND LIMITATIONS MAY NOT APPLY.

6. This Limited Warranty gives the Buyer specific legal rights, and the Buyer may also have other rights, which vary from state to state.

7. A return merchandise authorization ("RMA") must be obtained from Speck Pumps-Pool Products, Inc. before returning any product. Products returned without an RMA will be refused and returned, unopened, to the Buyer. All returned products are to be sent freight prepaid and insured for Buyer's protection to the manufacturer at 8125 Bayberry Road, Jacksonville, Florida 32256. Under no condition will products be accepted after the expiration of the Limited Warranty Period. Speck Pumps-Pool Products, Inc. shall not bear any costs or risks incurred by Buyer in shipping a defective pump and motor to Speck Pumps-Pool Products, Inc. or in shipping a repaired or replaced pump and motor to Buyer.

