



VORTEX®

ASSEMBLY AND INSTALLATION INSTRUCTIONS



WARNING

S.R. SMITH VORTEX SLIDES ARE MANUFACTURED FOR INSTALLATION AND USE ON INGROUND SWIMMING POOLS ONLY. THE VORTEX IS NEVER TO BE INSTALLED AND USED ON ABOVEGROUND POOLS, ONGROUND POOLS, HOUSEBOATS, BOAT DOCKS, FLOATING DOCKS OR PLATFORMS OR OTHER BODIES OF WATER SUCH AS LAKES, PONDS, RIVERS, ETC.

SRS AUSTRALIA, PTY LTD
12 Enterprise St
Richlands QLD 4077
Australia
Phone 07 3812 2283 • Fax 07 3812 1187
www.srsmith.com/au

S.R. SMITH, LLC
CORPORATE HEADQUARTERS
P.O. Box 400 • 1017 S.W. Berg Parkway
Canby, Oregon 97013
USA
Phone (503) 266 2231 • Fax (503) 266 4334
www.srsmith.com

TABLE OF CONTENTS

INTRODUCTION.....	3
INSTALLED VORTEX STRUCTURAL & INSTALLATION CHECKLIST	4
MAINTENANCE INSTRUCTIONS.....	4
ASSEMBLED VORTEX WITH STAIRS LAYOUT.....	5
ASSEMBLED VORTEX WITH LADDER LAYOUT	5
MAIN SECTION AND SLIDE RUNWAY PARTS LIST	7
Tools Required.....	8
Gasket Installation.....	8
VORTEX MAIN SECTION AND SLIDE RUNWAY ASSEMBLY INSTRUCTIONS	9
VORTEX CLOSED FLUME PARTS LIST.....	14
VORTEX CLOSED FLUME ASSEMBLY INSTRUCTIONS.....	15
VORTEX OPEN FLUME PARTS LIST	18
VORTEX OPEN FLUME ASSEMBLY INSTRUCTIONS	19
VORTEX STAIRWAY PARTS LIST.....	22
VORTEX STAIRWAY ASSEMBLY INSTRUCTIONS.....	23
VORTEX LADDER PARTS LIST	32
VORTEX LADDER ASSEMBLY INSTRUCTIONS	33
VORTEX WARNING SIGN PARTS LIST	35
VORTEX WARNING SIGN ASSEMBLY INSTRUCTIONS	36
VORTEX WATER SYSTEM PARTS LIST	37
WATER SYSTEM ASSEMBLY INSTRUCTIONS.....	38
CONCRETE WEDGE ANCHOR MOUNTING INSTRUCTIONS.....	43
MANUFACTURER'S PLACEMENT INSTRUCTIONS	44

SLIDE ASSEMBLY AND INSTALLATION VIDEOS AVAILABLE AT
www.youtube.com/srsmithllc

REGISTER YOUR S.R. SMITH PRODUCT AT
www.srsmith.com/en/customer-service/product-registration



Visit srsmith.com for information on the complete line of S.R. Smith pool products.

INTRODUCTION



DANGER – FAILURE TO FOLLOW THESE WARNINGS, INSTRUCTIONS, AND THE OWNER’S MANUAL MAY RESULT IN SERIOUS INJURY OR DEATH.

THE VORTEX IS DESIGNED AND MANUFACTURED FOR INSTALLATION AND USE ON INGROUND SWIMMING POOLS ONLY. DO NOT INSTALL THIS SLIDE ON ABOVEGROUND POOLS, HOUSEBOATS, BOAT DOCKS, FLOATING DOCKS OR PLATFORMS, OR OTHER BODIES OF WATER SUCH AS LAKES, PONDS, RIVERS, ETC. PROPER ASSEMBLY, INSTALLATION, USE, AND SUPERVISION ARE ESSENTIAL FOR PROPER OPERATION AND TO REDUCE THE RISK OF SERIOUS INJURY OR DEATH.

ALL NATIONAL AND LOCAL BUILDING CODES MUST BE FOLLOWED. THIS INCLUDES ANY APPLICABLE REQUIREMENTS FOR SIZE OF CONCRETE FOOTING, OVERALL HEIGHT OF SLIDE, AND BODING OR ELECTRICAL CODES.

CHECK INSIDE ALL BOXES AND PACKAGING MATERIALS FOR PARTS. BEFORE BEGINNING ASSEMBLY, READ ALL INSTRUCTIONS AND IDENTIFY PARTS USING THE FIGURES AND PARTS LISTED IN THIS DOCUMENT. IT IS CRITICAL THAT ALL PARTS BE CAREFULLY INSPECTED BY THE INSTALLER PRIOR TO INSTALLATION TO ENSURE THAT NO DAMAGE OCCURRED IN TRANSIT AND THAT A DAMAGED PART IS NOT USED. PROPER INSTALLATION CANNOT BE OVERSTRESSED. IMPROPER INSTALLATION VOIDS THE S.R. SMITH WARRANTY AND MAY AFFECT THE SAFETY OF THE USER.

PRECAUTION: POWDER COATING IS SCRATCH RESISTANT, NOT SCRATCH PROOF. IT IS STILL SUSCEPTIBLE TO SCRATCHING AND CHIPPING. THIS SHOULD BE PREVENTED BECAUSE EXPOSED METAL SURFACES WILL RUST.

PRECAUTION: CONTACT YOUR POOL PROFESSIONAL TO MAKE SURE THAT YOU HAVE ADEQUATE ACCESS TO YOUR POOL PUMP HOUSE FOR THE WATER SUPPLY. IT IS STRONGLY RECOMMENDED THAT THE WATER LINE BE PULLED FROM THE SWIMMING POOL RETURN LINE SO THAT THE CIRCULATED WATER IS SANITARY AND DOES NOT AFFECT THE CHEMISTRY OF THE POOL.

INSTALLER MUST GIVE TO SLIDE OWNER: VORTEX SLIDE INSTALLATION AND OWNER’S MANUAL, THE WARRANTY CARD, AND ANSWER ALL QUESTIONS REGARDING SAFE AND PROPER USE AND SLIDE MAINTENANCE.

WARNING SIGN MUST BE MOUNTED NEAR SLIDE ENTRANCE. SIGN SHOULD BE LOCATED WITHIN 2 FEET OF THE ENTRANCE OF THE SLIDE AND MUST POINT AWAY FROM ENTRANCE SO THAT IT IS VISIBLE AT LEAST 10 FEET FROM SLIDE.

FOR COMPLETE SLIDE SAFETY INFORMATION REFER TO THE OWNER’S MANUAL.

INSTALLED VORTEX STRUCTURAL & INSTALLATION CHECKLIST

Installer to review this checklist with slide's owner upon completion of slide installation.

1. Inspect the runway for visible cracks or tears.
2. Inspect the ladder for sharp edges, protrusions, cracks, or tears.
3. Inspect all fasteners to make sure they are fully tightened.
4. Inspect the ladder for structural stability.
5. Measure the following dimensions and compare with the manufacturer's placement instructions listed on pages 44 and 45.
 - Measure the depth of water in front of the slide exit. (4'-6" min. Depth at a distance of 4'-6" from exit end of slide.)
 - Measure the height of the slide runway exit above the water. (20" max.)
 - Measure the distance between the centerline of the slide and the edge of other pool equipment.
6. Observe the position of the exit of the slide as shown on pages 44 and 45.

MAINTENANCE INSTRUCTIONS

1. Periodically inspect the vortex to assure there are no worn parts and that all hardware is properly tightened. Replace any hardware which exhibits rust or corrosion.
2. All slide components require periodic maintenance. Clean components with a cotton cloth and a non-abrasive soap and water. Avoid harsh chemicals and disinfectants.
3. Always read the label instructions on any cleaner carefully before applying it to a surface.
4. Inspect the plumbing system for leaks. Freeze/thaw cycles may cause leaks at plumbing joints which should be repaired prior to use.
5. Check all safety labels to insure they have not peeled or been removed. Contact S.R. Smith customer service (800-824-4397) for replacement labels.
6. The support structure is made from steel, is primed and powder coated with a high quality acrylic urethane finish. However, corrosion may occur depending on water chemistry and environmental conditions. Inspect the slide on a semi-annual basis, sand and repair any surface rust. For touch-up paint (PN # 09-819-1), contact S.R. Smith customer service (800-824-4397).

CAUTION:

BECAUSE THIS PRODUCT IS MANUFACTURED FROM STEEL, PLACEMENT ON A POOL WITH A SALT CHLORINE GENERATOR WILL REQUIRE FREQUENT INSPECTION AND MAINTENANCE DUE TO THE CORROSIVE NATURE OF THESE SYSTEMS WITH ALL STEEL ALLOYS. IT IS RECOMMENDED THAT ALL SLIDE COMPONENTS BE RINSED DAILY WITH FRESH WATER.

ASSEMBLED VORTEX WITH STAIRS LAYOUT

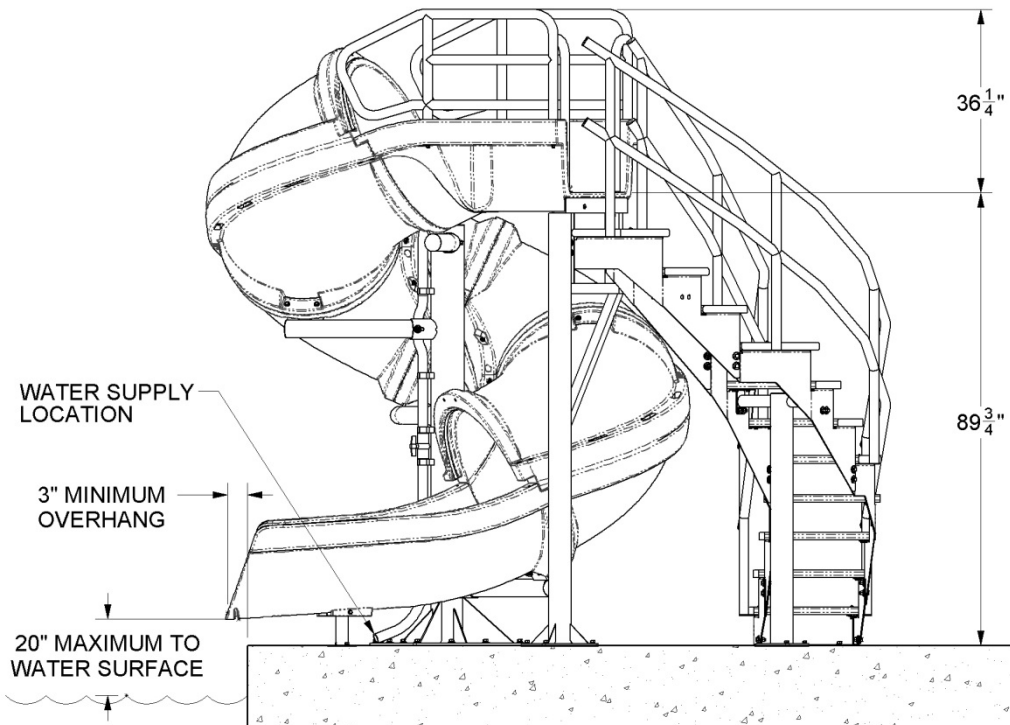
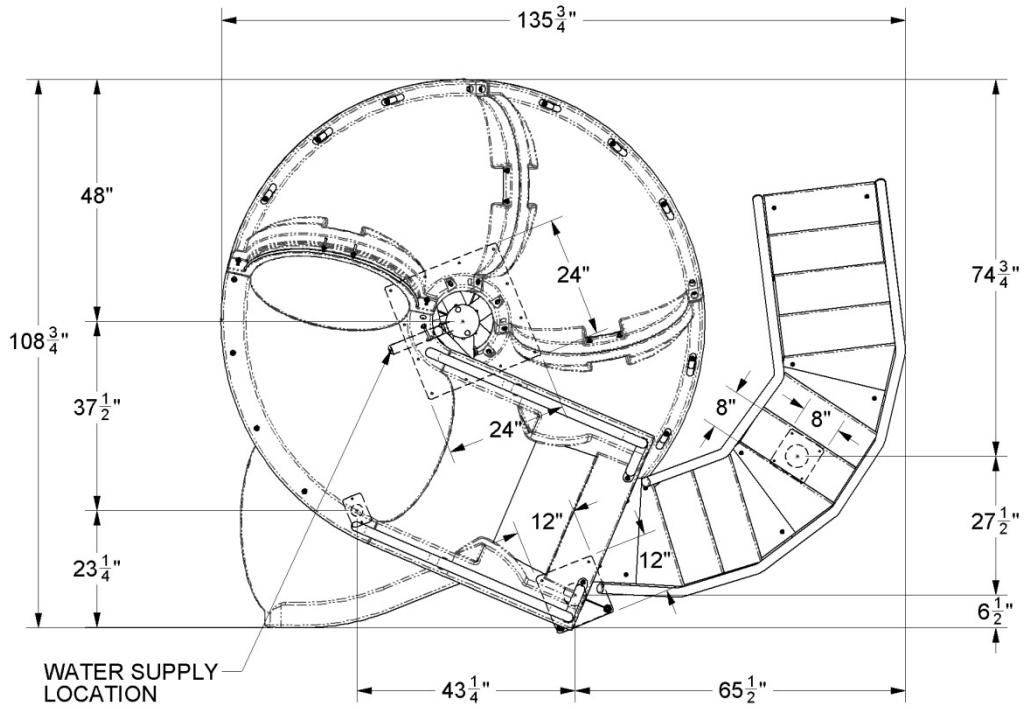

FIGURE A

ASSEMBLED VORTEX WITH LADDER LAYOUT

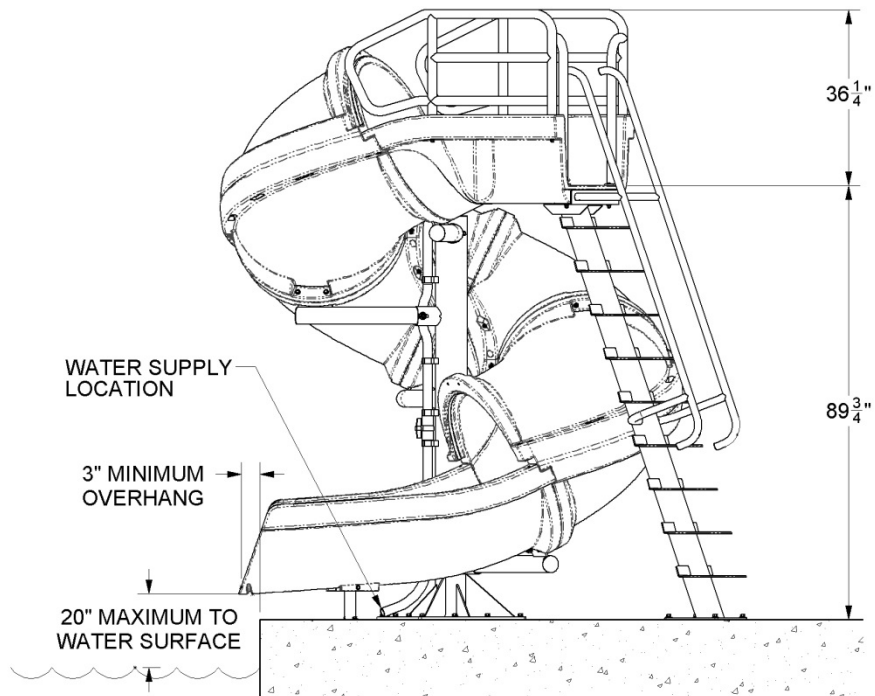
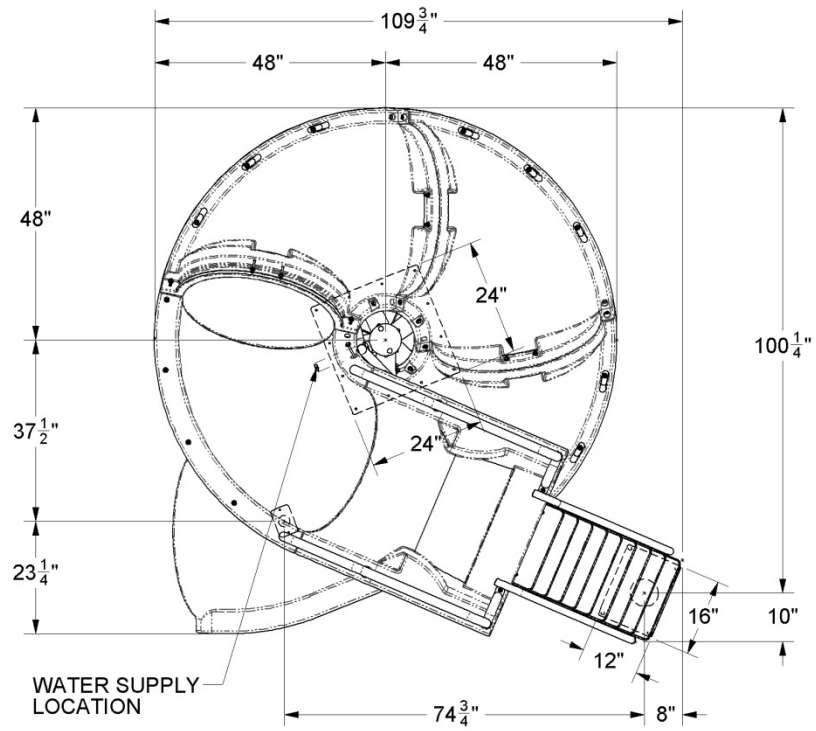
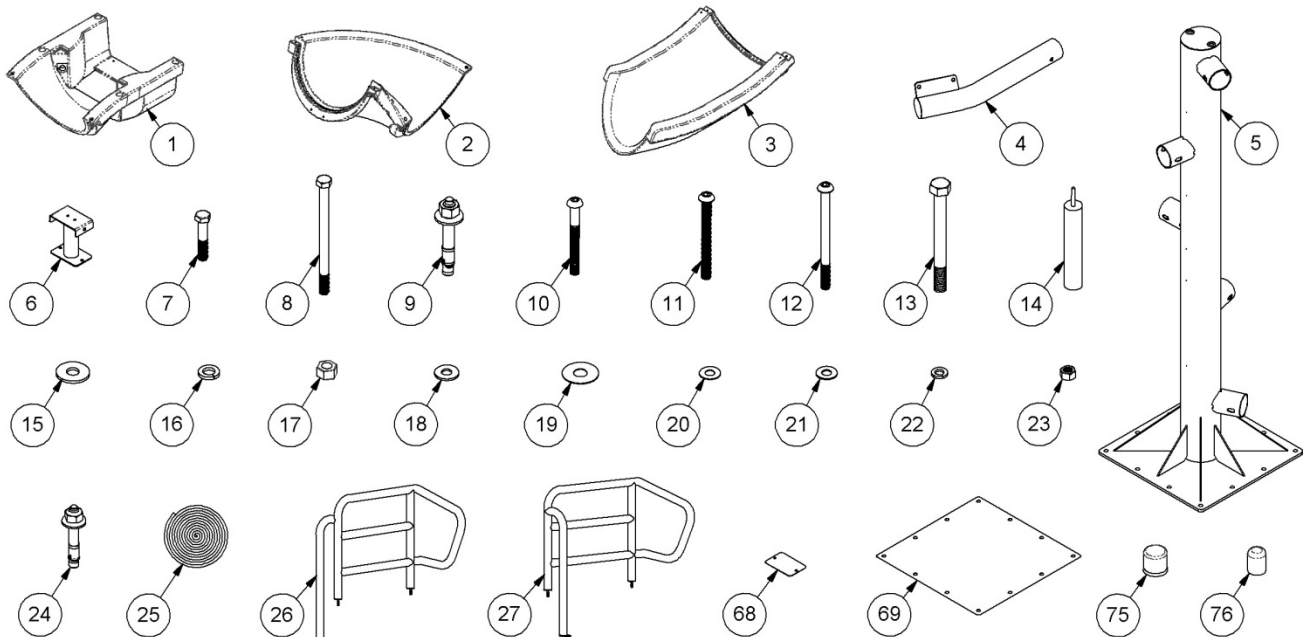

FIGURE B

MAIN SECTION AND SLIDE RUNWAY PARTS LIST

ITEM NO.	PART NO.	DESCRIPTION	QTY.	KIT A	KIT B	KIT C
KIT A	66-209-177	FLUME HARDWARE KIT	1 ea.			
KIT B	66-209-178	HALF FLUME HARDWARE KIT	1 ea.			
KIT C	66-209-311	UNIVERSAL SPARE HARDWARE KIT	1 ea.			
1	6-690-1	ENTRANCE SECTION	1 ea.			
2	6-690-2	RUNWAY SECTION	4 ea.			
3	6-690-3	EXIT SECTION	1 ea.			
4	14-301	BRANCH ARM	5 ea.			
5	14-300	MAIN SUPPORT	1 ea.			
6	14-205	EXIT SUPPORT	1 ea.			
7	5-113	3/8" x 2" HHCS S/S	2 ea.	•	•	
8	05-32-131	3/8" x 5-1/2" HHCS	8 ea.	•	•	
9	5-523	1/2" x 3-3/4" CONC. ANCHOR W/ HARDWARE	12 ea.	•	•	
10	5-250	3/8" x 3-1/2" BHCS S/S	2 ea.	•	•	
11	5-512	3/8" x 4" BHCS S/S	8 ea.	•	•	
12	5-515	3/8" x 5" BHCS S/S	4 ea.	•	•	
13	5-524-SS	1/2" x 5" HHCS S/S	5 ea.	•	•	
14	VULKEM-116	VULKEM GRAY SEALANT	1 ea.			
15	05-14-132	1/2" x 1-3/8" FLAT WASHER S/S	10 ea.	•	•	•
16	05-14-115	1/2" LOCK WASHER S/S	17 ea.	•	•	•
17	05-14-116	1/2" HEX NUT S/S	5 ea.	•	•	•
18	05-14-107	3/8" x 1" FLAT WASHER S/S	16 ea.	•	•	•
19	05-616	1/2" NYLON WASHER	22 ea.	•	•	•
20	05-32-111	3/8" NYLON WASHER	18 ea.	•	•	•
21	5-145	3/8" x 7/8" FLAT WASHER S/S	34 ea.	•	•	•
22	5-151	3/8" LOCK WASHER S/S	30 ea.	•	•	•
23	5-139	3/8" HEX NUT S/S	26 ea.	•	•	•
24	5-521	3/8-16 x 3" CONC. ANCHOR W/ HARDWARE	2 ea.	•	•	
25	8-536	1/2" WIDE x 1/3" TALL RUBBER GASKET	21 ft.			
26	14-203	RIGHT GUARD RAIL	1 ea.			
27	14-204	LEFT GUARD RAIL	1 ea.			
68	05-237	HDPE GASKET FOR EXIT SUPPORT	1 ea.			
69	05-234	HDPE GASKET FOR MAIN SUPPORT	1 ea.			
75	05-618	1/2" NUT CAP - GRAY PLASTIC	12 ea.			
76	05-608	3/8" x 1" NUT CAP - BLACK RUBBER	2 ea.			

Visit srsmith.com for hardware kit and replacement part information.



Tools Required

- | | | | |
|-----|-------------------------------|-----|---------------------------------------|
| 1. | Ratchet Handle | 12. | 4 Irwin Quick Grip™ 18" XP Bar Clamps |
| 2. | 9/16" Socket (Deep) | 13. | Power Drill |
| 3. | 9/16" Wrench | 14. | PVC Pipe Primer & Glue |
| 4. | 3/4" Socket or Wrench (Deep) | 15. | Anti-Seize |
| 5. | 7/32" Allen Wrench (Deep) | 16. | Saw to Cut PVC Pipe |
| 6. | Phillips Head Screwdriver | 17. | Knife |
| 7. | Roto-Hammer Drill | 18. | Level |
| 8. | 1/4" Drill Bit for Step Assy. | 19. | Hammer |
| 9. | 1/2" Concrete Drill Bit | 20. | 8' Step Ladder |
| 10. | 3/8" Concrete Drill Bit | 21. | Rubber Mallet |
| 11. | 4" Ratchet Extension | 22. | Torque Wrench |

Gasket Installation

- The gasket material has been installed at the factory, however additional gasket has been provided in case any gasket has fallen off during shipping. If gasket installation is required, follow the instructions below.
- Apply gasket in the required locations as shown in the figures below.
- Place gasket along the section to determine the length needed.
- Cut gasket to appropriate length.
- Remove backing and adhere gasket to slide.

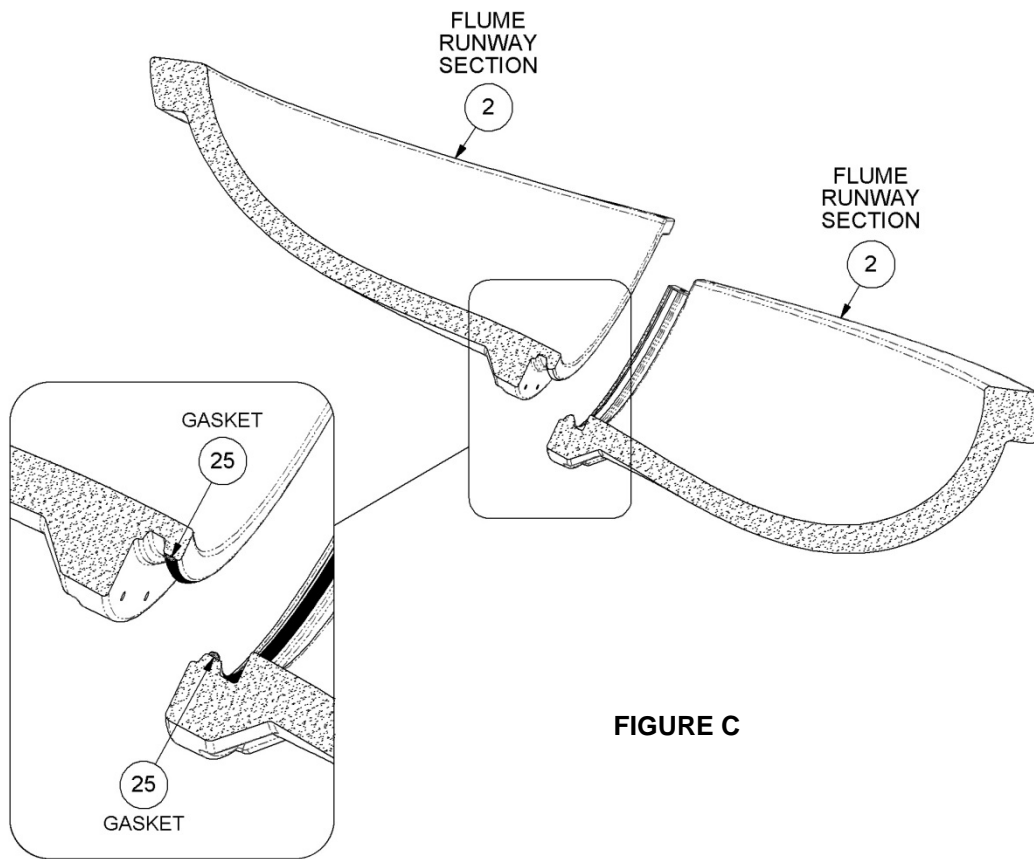

FIGURE C

VORTEX MAIN SECTION AND SLIDE RUNWAY ASSEMBLY INSTRUCTIONS

1. Insert all five of the Branch Arms (4) into the Main Support (5). Carefully slide the arms into the support sockets to ensure the powder coating is not damaged. Align the holes in the branch arms with the slots in the main tube support and fasten them as shown in Figure D.

The required hardware is as follows: 1/2"-13 x 5" Hex Head Cap Screw (13), 1/2" Flat Washer (15), 1/2" Nylon Washer (19), and 1/2" Nylon Washer (19), 1/2" Flat Washer (15), 1/2" Lock Washer (16), 1/2" Hex Nut (17) on the other side of the support.

ANTI-SEIZE NEEDS TO BE USED ON ALL BOLTS, and should be applied to the threads before attempting to place the nut on the bolt.

Note: It is important to NOT TIGHTEN the hardware at this point.

Place the column near the installation location.

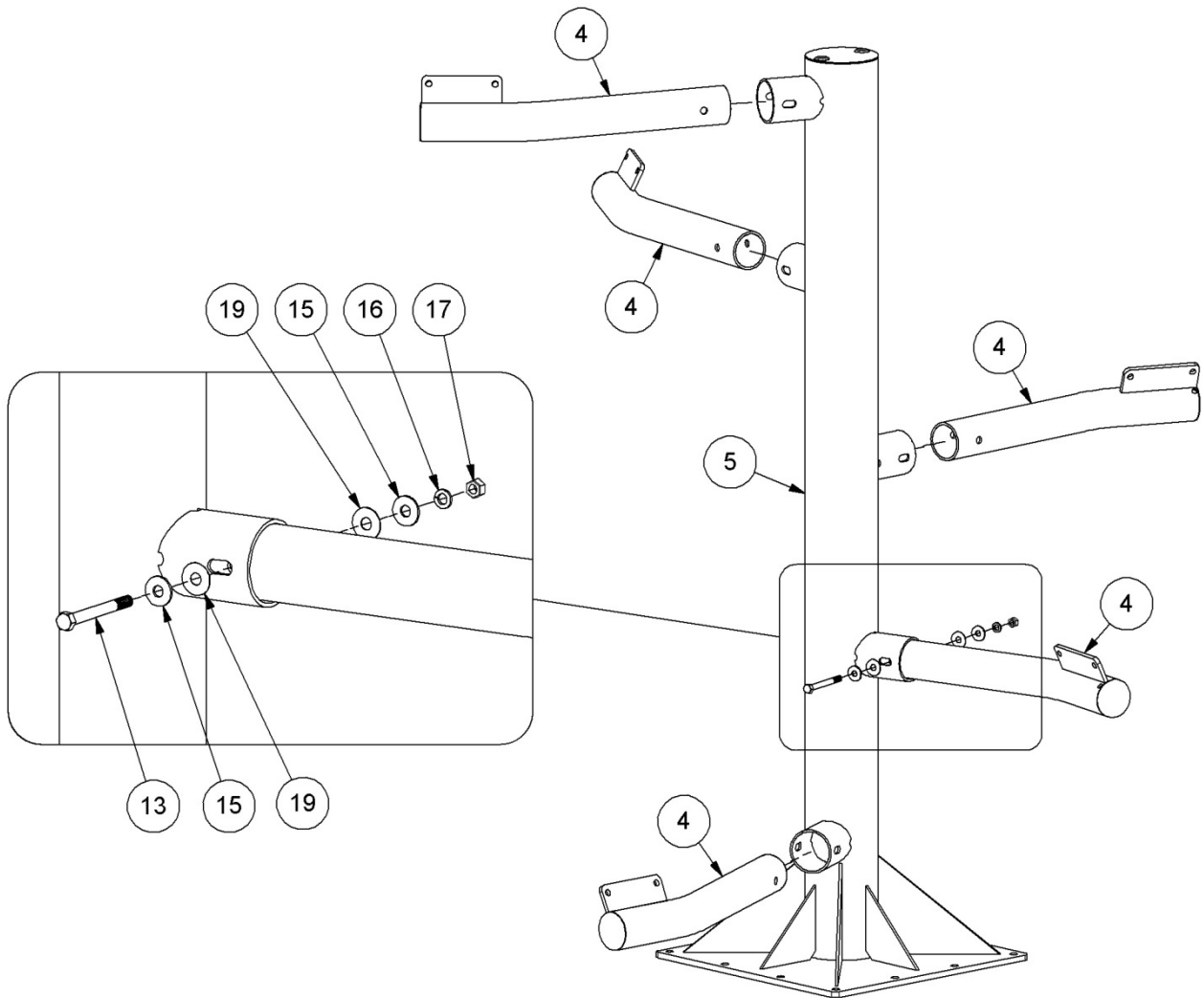

FIGURE D

Note: Before working with the flume pieces, cover the concrete with cardboard or carpet to prevent scratching the plastic slide components.

The order of assembly is important!

All of the Runway Sections (2) are labeled at both ends indicating the order in which they need to be assembled.

2. Assemble the Exit Flume (3) and the Runway Section (2) as shown in Figure E. Make sure that the Runway Section (2) that you are installing is labeled B1 on one end and B2 on the other. Install the hardware through both side rails. The required hardware is as follows: 3/8"-16 x 4" Button Head Cap Screw S/S (11), 3/8" Flat Washer (21), 3/8" Flat Washer (21), 3/8" Lock Washer (22), 3/8" Hex Nut S/S (23). Tighten the hardware until snug.

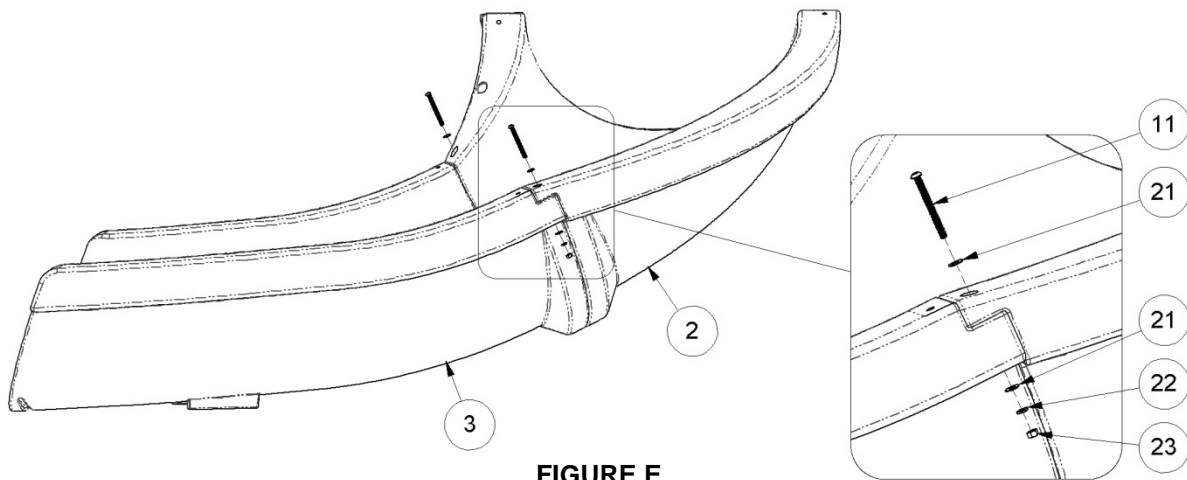

FIGURE E

3. Turn the two previously connected flume parts upside down. Attach the Exit Support (6) to the Exit Flume (3), as shown in Figure F. The required hardware is as follows: 3/8"-16 x 2" Hex Head Bolt (7), 3/8" Flat Washer (21) on the outside and 3/8" Nylon Washer (20), 3/8" Flat Washer (21), 3/8" Lock Washer (22), 3/8" Hex Nut (23) on the inside. Tighten the hardware until snug.

Note: Apply anti-seize to all fasteners to prevent galling.

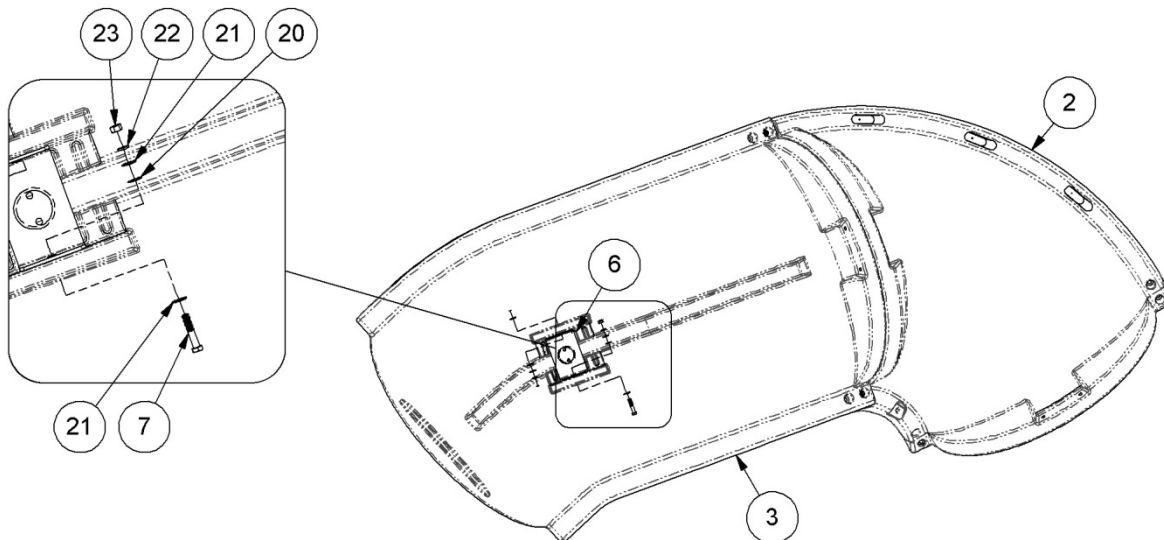
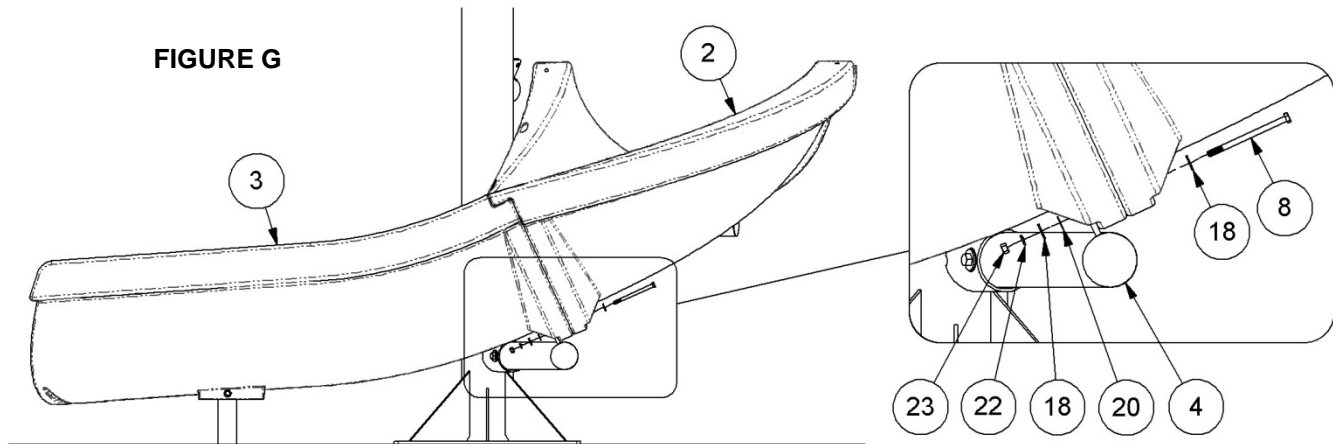

FIGURE F

- Place the assembled Exit Flume (3) and Runway Section (2) over the first Branch Arm (4). Attach the slide sections to the first branch arm as shown in Figure G. The required hardware is as follows: 3/8"-16 x 5-1/2" Hex Head Cap Screw (8), 3/8" Flat Washer (18), 3/8" Nylon Washer (20), 3/8" Flat Washer (18), 3/8" Lock Washer (22), and a 3/8" Hex Nut (23).

Note: Do not completely tighten the hardware at this point. Be sure to apply anti-seize to all fasteners to prevent galling.



- With the Exit Flume (3) and Runway Section (2) connected to the branch arm (4), position the slide exit in accordance with the Manufacturer's Placement Instructions listed on page 44 and 45. Temporarily place bolts through the other end of Runway Section (2) into the second branch arm to ensure proper alignment. Once the assembly is in the correct position, mark the locations for the main support and the exit support anchors. Move the assembly aside then drill 1/2"Ø x 4" deep holes for the Main Support (5) concrete wedge anchors and 3/8"Ø x 4" deep holes for the Exit Support (6) concrete wedge anchors. Move the assembly back into place, with the HDPE Gaskets (68) and (69) between the base plates and deck. Then install the wedge anchors in accordance with the instructions on page 43.

The required hardware for the Main Support (5) anchors is as follows: 1/2" Wedge Anchor with hardware (9), 1/2" Nylon Washer (19), 1/2" Lock Washer (16), Nut Cap (75). See Figure H for order of assembly.

The required hardware for the Exit Support (6) anchors is as follows: 3/8" Wedge Anchor with hardware (24), 3/8" Nylon Washer (20), 3/8" Lock Washer (22), Nut Cap (69). See Figure H for order of assembly.

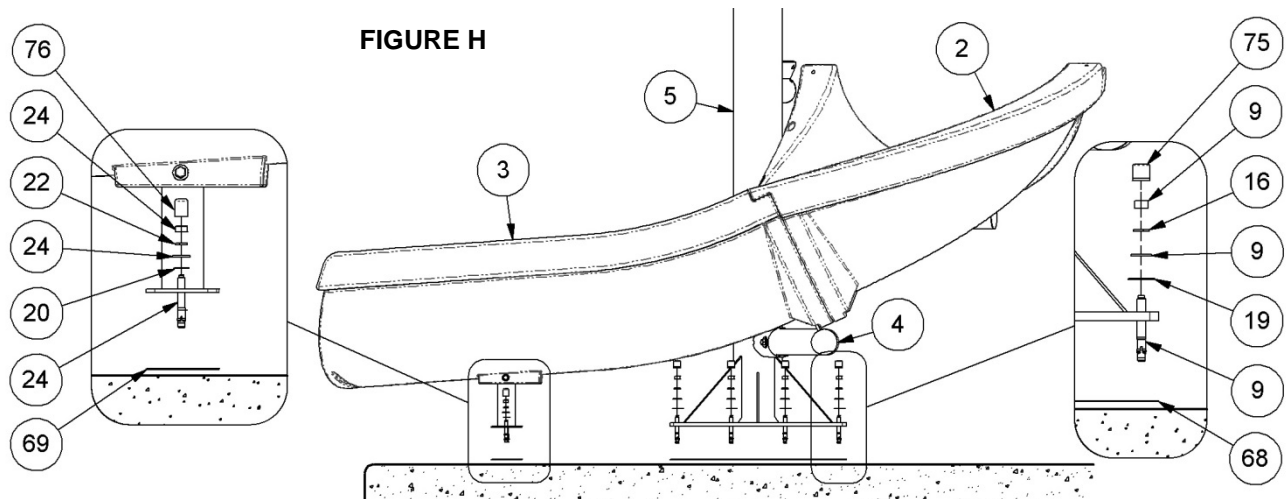

- Fasten the sides of Runway Section (2) labeled B2 to the previously assembled runway section using the fasteners shown in Figure E. Then attach the bottom of Runway Section (2) to the branch arm using the fasteners shown in Figure G.

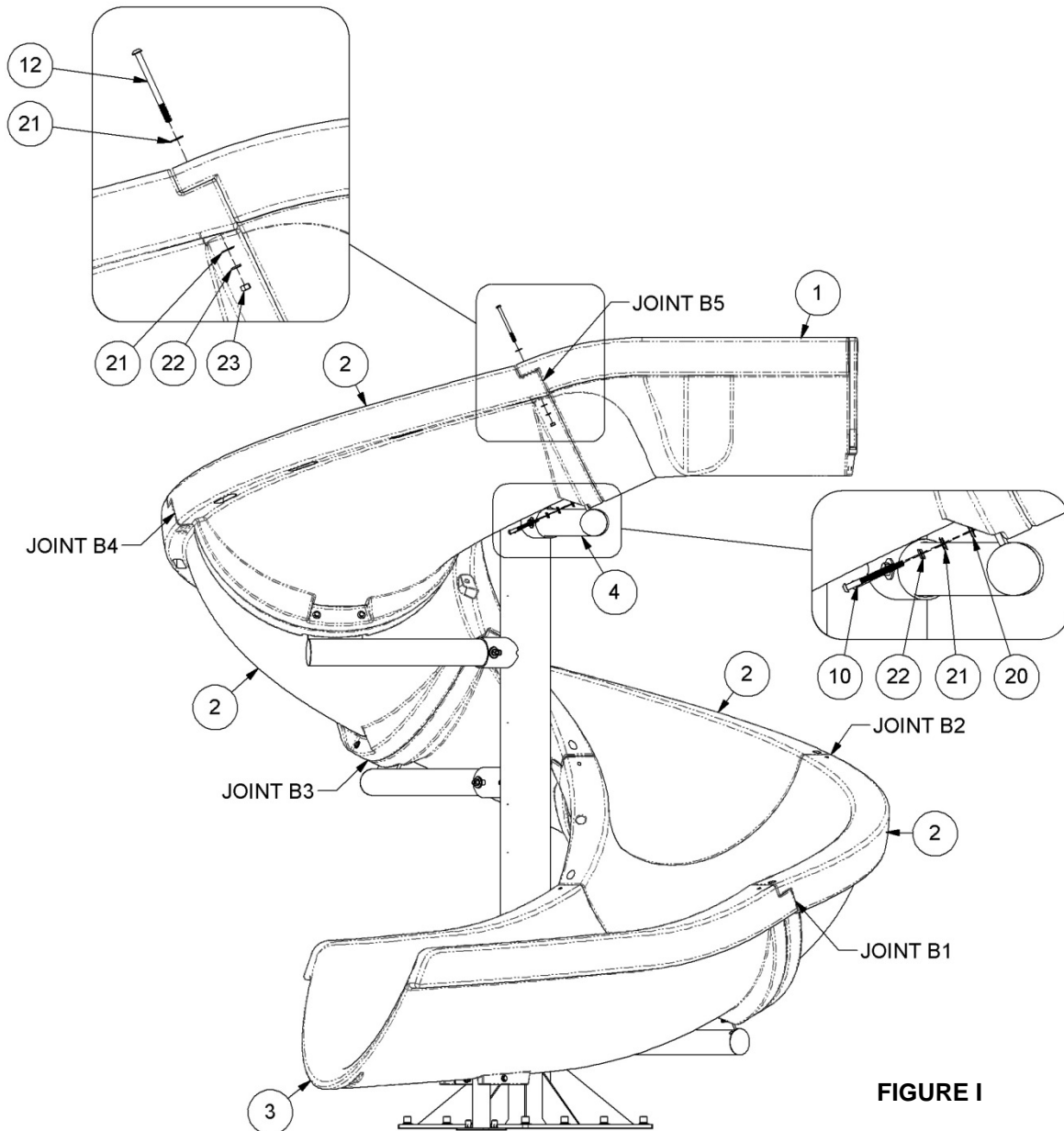

FIGURE I

- Repeat this process for the three remaining Runway Sections. **Remember that order of assembly is important.** The end of each runway section is labeled and must be assembled to the runway section with the same label.

Assembly Tip: It is recommended that Irwin Quick Grip bar clamps be used to help align the fastener holes in the runway sections.

- Attach the Entrance Section (1) to the last Runway Section (2). Fasten the sides of the Entrance Section (1) as shown in Figure I. The hardware required is as follows: 3/8"-16 x 5" Button Head Cap Screw S/S (12), 3/8" Flat Washer S/S (21), 3/8" Flat Washer S/S (21), 3/8" Lock Washer S/S (22), 3/8" Hex Nut S/S (23).

9. Fasten the bottom of the Entrance Section (1) to the branch arm, as shown in Figure I. The screws will be screwed into the threaded inserts in the Entrance Section (1). The hardware required is as follows: 3/8"-16 x 3-1/2" Button Head Cap Screw S/S (10), 3/8" Lock Washer S/S (21), 3/8" Flat Washer S/S (22), and a 3/8" Nylon Washer (20).

Note: Be sure to apply anti-seize to all fasteners to prevent galling.

After you have started all of these bolts, go back through and tighten all of the fasteners installed up to this point.

Apply the 1/2" wide X 0.3" tall gasket to the top runway parts along the outside curve edge only. The gasket should be applied on the mating surface, between the bolt holes and the inside edge of the part.

10. Insert the Left Guard Rail (26) and the Right Guard Rail (27) into the two sockets on the top of the Entrance Section (1), as shown in Figure J, so that the threaded stud ends come through the slide side rails.

The hardware required to secure the studded Guard Rail legs are as follows: 3/8" Flat Washer (21), 3/8" Lock Washer (22), and a 3/8" Hex Nut (23). **After all hardware has been attached tighten each bolt securely.**

Fasten the following hardware to attach the guardrail feet to the entrance section: 3/8" x 5" Button Head Cap Screw, (12), 3/8" Flat Washer (21), 3/8" Nylon Washer (20), 3/8" Nylon Washer (20), 3/8" Flat Washer (21), 3/8" Lock Washer (22), and a 3/8" Hex Nut (23). **Do not fully tighten the nuts yet because the fasteners will need to be removed later when installing the ladder or stairway.**

Note: Be sure to apply anti-seize to all fasteners to prevent galling.

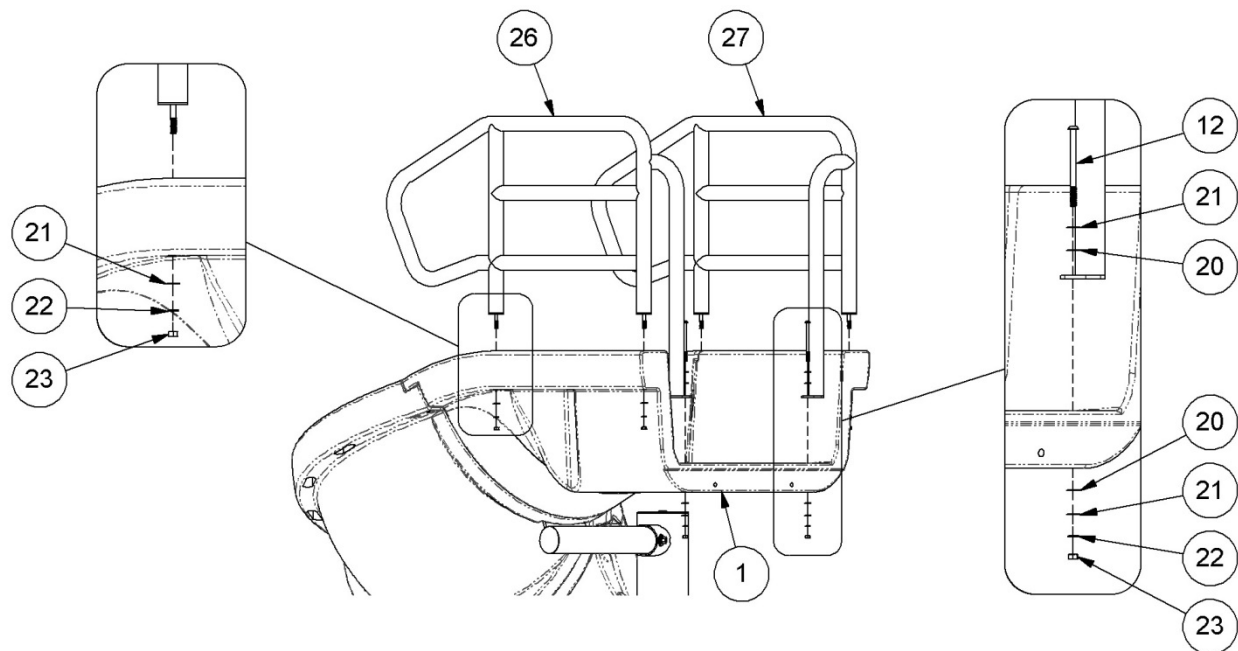
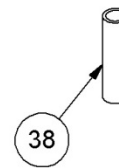
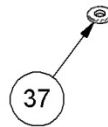
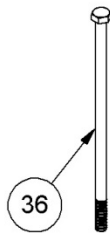
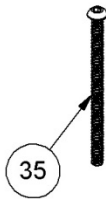
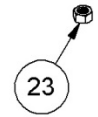
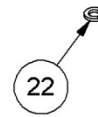
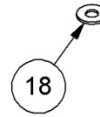
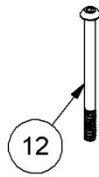
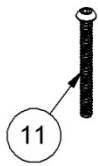
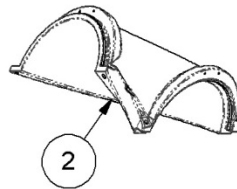

FIGURE J

VORTEX CLOSED FLUME PARTS LIST

ITEM NO.	PART NO.	DESCRIPTION	QTY.	KIT A
KIT A	66-209-177	FLUME HARDWARE KIT	1 ea.	
2	6-690-2	RUNWAY SECTION	4 ea.	•
11	5-512	3/8" x 4" BHCS S/S	6 ea.	•
12	5-515	3/8" x 5" BHCS S/S	18 ea.	•
18	5-518	3/8" x 1" FLAT WASHER S/S	72 ea.	•
22	5-516	3/8" LOCK WASHER S/S	30 ea.	•
23	05-14-107	3/8"-16 HEX NUT S/S	30 ea.	•
35	5-151	3/8" x 6" BHCS S/S	2 ea.	•
36	5-139	3/8" x 8-1/2" HHCS S/S	4 ea.	•
37	05-626	3/8" RUBBER WASHER	4 ea.	•
38	1-300-2	1/2" SCH 40 PVC SPACER 2-3/4"	12 ea.	•

Visit srsmith.com for hardware kit and replacement part information.



VORTEX CLOSED FLUME ASSEMBLY INSTRUCTIONS

1. Assemble the four remaining Runway Section (2) pieces. **Order of assembly is important.** The end of each runway section is labeled and must be assembled to the runway section with the same label.

Assemble the lower two sections. They are labeled T1 on their mating ends. Fasten the sections together using the screw hole locations located at the sides and the top of the Runway Section (2) as shown in Figure K.

The hardware required for the two side locations is as follows: 3/8"-16 x 4" Button Head Cap Screw S/S (11), 3/8" Flat Washer S/S (18), 3/8" Flat Washer S/S (18), 3/8" Lock Washer S/S (22), 3/8" Hex Nut S/S (23).

The hardware required for the top location is as follows: 3/8"-16 x 5" Button Head Cap Screw (12), and a 3/8" Flat Washer S/S (18), 3/8" Flat Washer (18), 3/8" Lock Washer (22), 3/8" Hex Nut (23).

Follow the same procedure to finish assembling the remaining two sections. First, assemble the Runway Sections (2) labeled T2, followed by the Runway Section (2) labeled T3.

Note: Be sure to apply anti-seize to all fasteners to prevent galling.

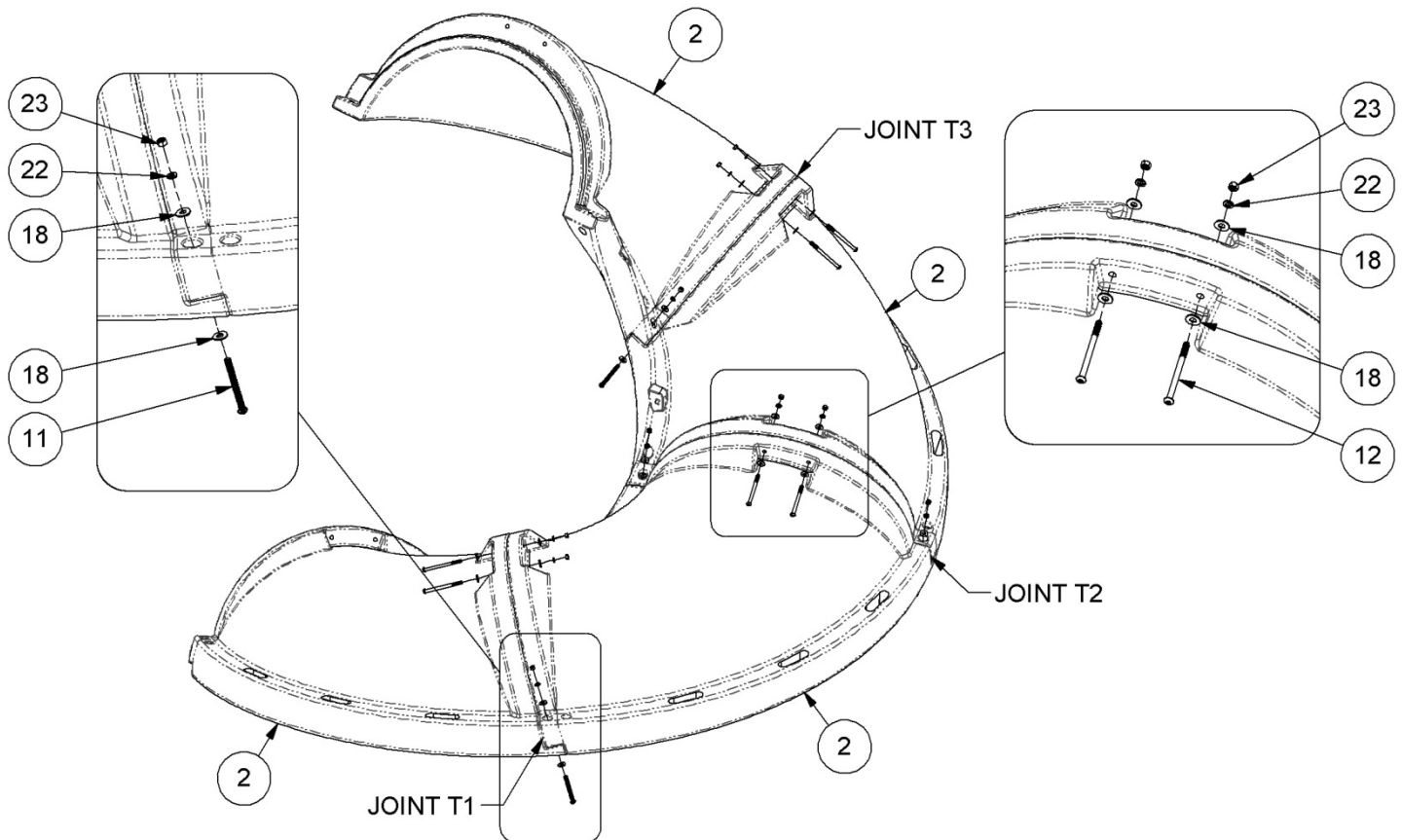

FIGURE K

2. **Make sure the gasket is in place.** Slide all four assembled parts of the cover flume up the slide from the bottom. You will need 3-4 people to assist in getting it positioned correctly.

Attach the hardware at the top of the runway as shown in Figure L. The hardware required for this step is as follows: 3/8"-16 x 6" Button Head Cap Screw S/S (35), 3/8" Flat Washer S/S (18), 3/8" Flat Washer S/S (18), 3/8" Lock Washer S/S (22), 3/8" Hex Nut S/S (23).

Next, working from the top to bottom, fasten the flumes together along the outside edge as shown in Figure 12. The required hardware is as follows: a 3/8"-16 x 5" Button Head Cap Screw S/S (12), 3/8" Flat Washer S/S (18), 3/8" Flat Washer S/S (18), 1/2" Sch. 40 PVC Spacer 3-1/4" (38), 3/8" Flat Washer S/S (18), 3/8" Lock Washer S/S (22), 3/8" Hex Nut S/S (23).

Tighten the hardware until the gap in the joint is closed.

Do not over tighten.

Note: Be sure to apply anti-seize to all fasteners to prevent galling.

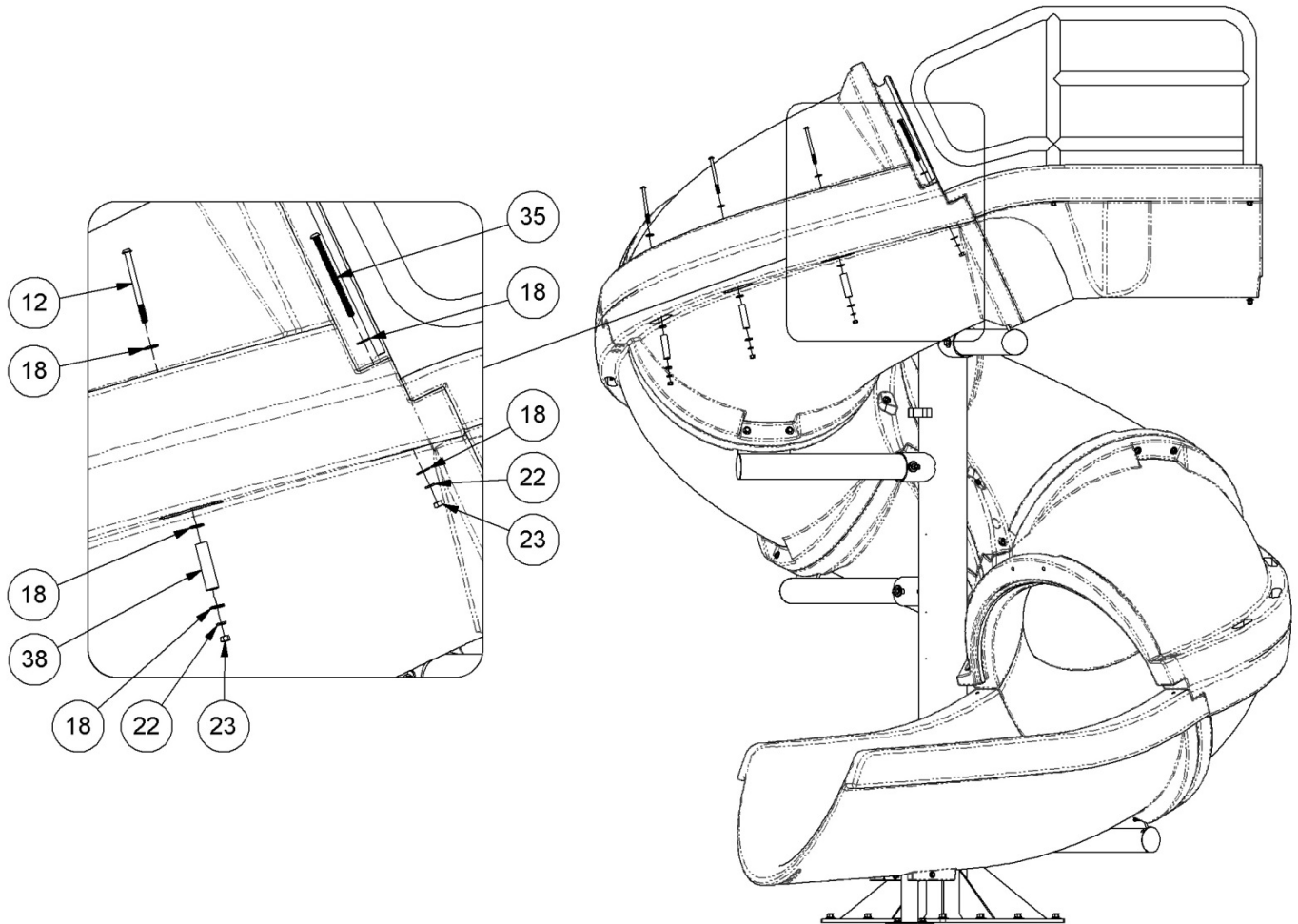

FIGURE L

3. Fasten the top and bottom runway parts together along the inside curve as shown in Figure 13. The hardware required for this step is as follows: a 3/8"-16 x 8-1/2" Hex Head Cap Screw S/S (14), 3/8" Flat Washer S/S (21), 3/8" Rubber Washer (27), 3/8" Flat Washer S/S (21), 3/8" Lock Washer S/S (25), 3/8" Hex Nut S/S (26). There are four locations where this step is repeated.

After you have started all of these bolts, you should go back through and tighten all of the fasteners installed up to this point .

Note: Be sure to apply anti-seize to all fasteners to prevent galling.

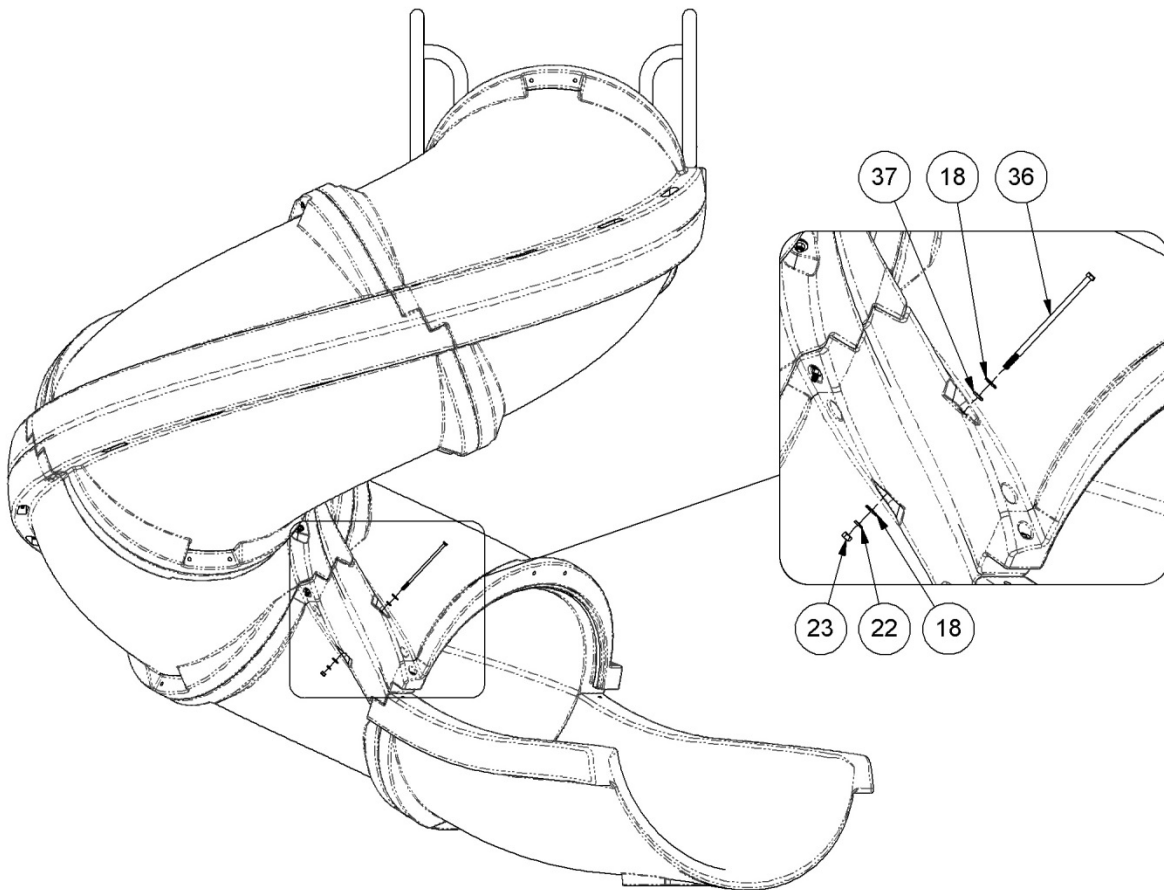
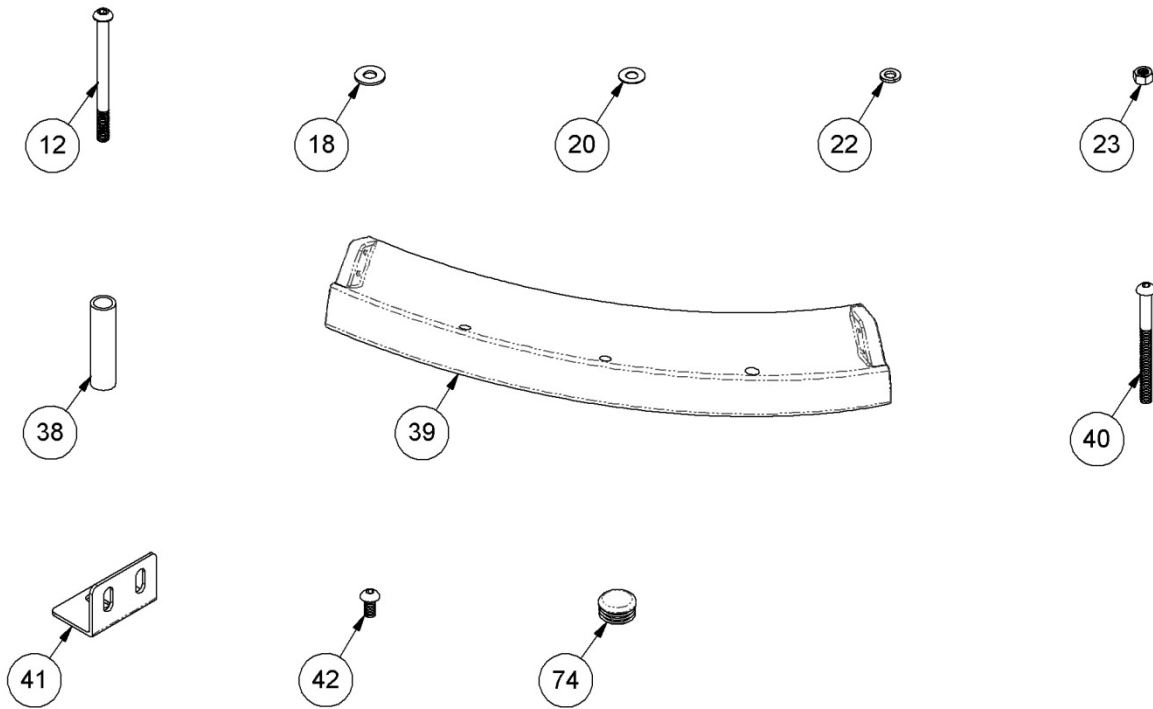

FIGURE M

VORTEX OPEN FLUME PARTS LIST

ITEM NO.	PART NO.	DESCRIPTION	QTY.	KIT B
KIT B	66-209-178	HALF FLUME HARDWARE KIT	1 ea.	
12	5-515	3/8" x 5" BHCS S/S	13 ea.	•
18	05-14-107	3/8" x 1" OD FLAT WASHER S/S	54 ea.	•
20	05-32-111	3/8" NYLON WASHER	6 ea.	•
22	5-151	3/8" LOCK WASHER S/S	19 ea.	•
23	5-139	3/8" HEX NUT S/S	19 ea.	•
38	1-300-2	1/2" SCH 40 PVC SPACER 2-3/4"	12 ea.	•
39	6-690-4	CURVE SECTION RISER	4 ea.	
40	5-513	3/8" x 4-1/2" BHCS S/S	6 ea.	•
41	4-235	CURVE SECTION RISER BRACKET S/S	2 ea.	•
42	5-514	3/8" x 3/4" BHCS S/S	4 ea.	•
74	8-537	CCF-1-1/4"-14-20, BLACK PE PLUG	12 ea.	•

Visit srsmith.com for hardware kit and replacement part information.



VORTEX OPEN FLUME ASSEMBLY INSTRUCTIONS

1. Assemble the four Curve Section Riser (39) pieces. Fasten the two sections together using the two bolt locations through the side of the parts as shown in Figure N. The hardware required for the two side locations is as follows: 3/8"-16 x 4-1/2" Button Head Cap Screw S/S (40), 3/8" Flat Washer S/S (18), 3/8" Flat Washer S/S (18), 3/8" Lock Washer S/S (22), 3/8" Hex Nut S/S (23).

Follow the same procedure to finish assembling the remaining two sections together.

**Do not fully tighten any of the hardware until all of the hardware has been assembled.
Do not over tighten. Be sure to apply anti-seize to all fasteners to prevent galling.**

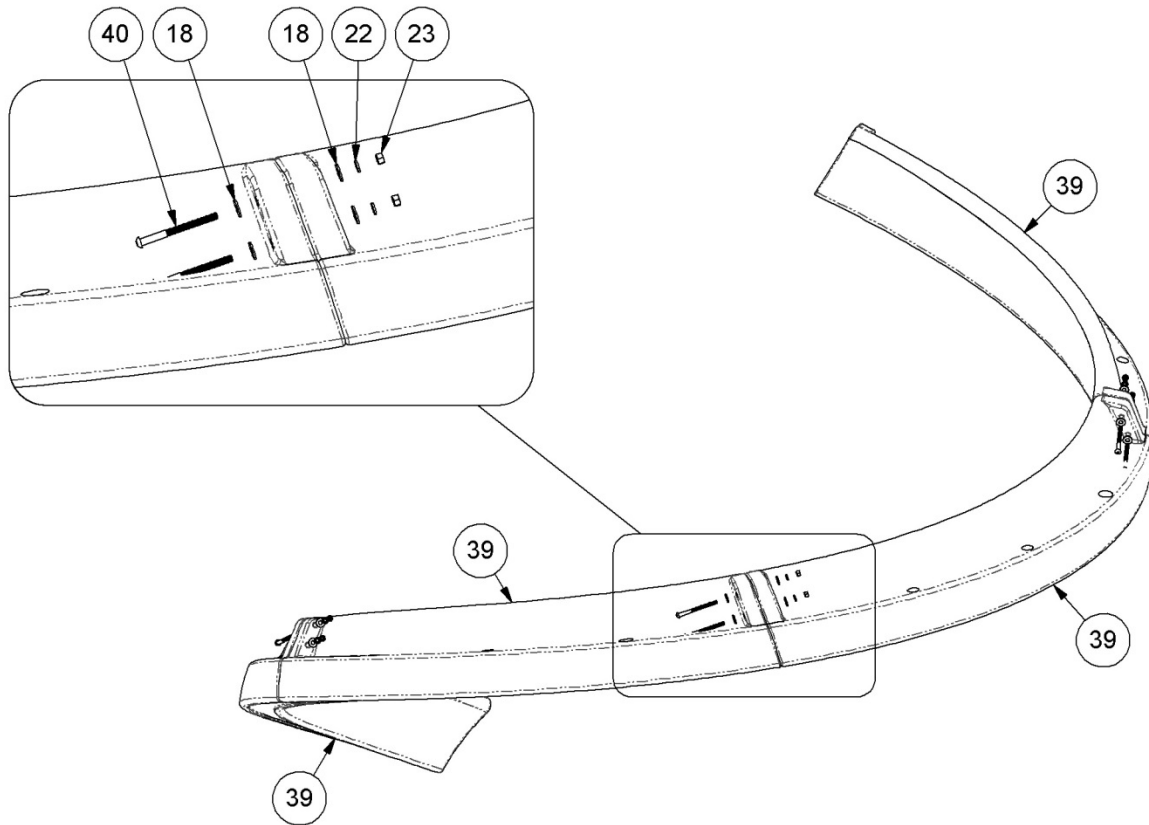

FIGURE N

2. Make sure the gasket is in place.
3. Slide all four pieces of the open flume up the slide from the bottom. Attach the hardware at the top of the runway as shown in Figure O. Use the Riser Bracket (41) to secure the Open Flume Risers to the Runway.
4. Connect the Bracket to the Runway Flume with a 3/8"-16 x 5" Button Head Cap Screw S/S (12), 3/8" Flat Washer S/S (18), 3/8" Nylon Washer (20), 3/8" Flat Washer S/S (18), 3/8" Lock Washer S/S (22), 3/8" Hex Nut S/S (23).

Note: When installing the upper Riser Bracket, remove and reuse the existing hardware previously installed during the main section installation. See Figure O. Add a Nylon Washer (20) to protect the Riser Bracket's powder coat finish.

5. Install a 3/8"-16 x 3/4" Button Head Cap Screw S/S (42), 3/8" Flat Washer S/S (18), and 3/8" Nylon Washer (20) through the Riser Bracket (41) and the Open Flume Riser.

**Do not fully tighten any of the hardware until all of the hardware has been assembled.
Do not over tighten. Be sure to apply anti-seize to all fasteners to prevent galling.**

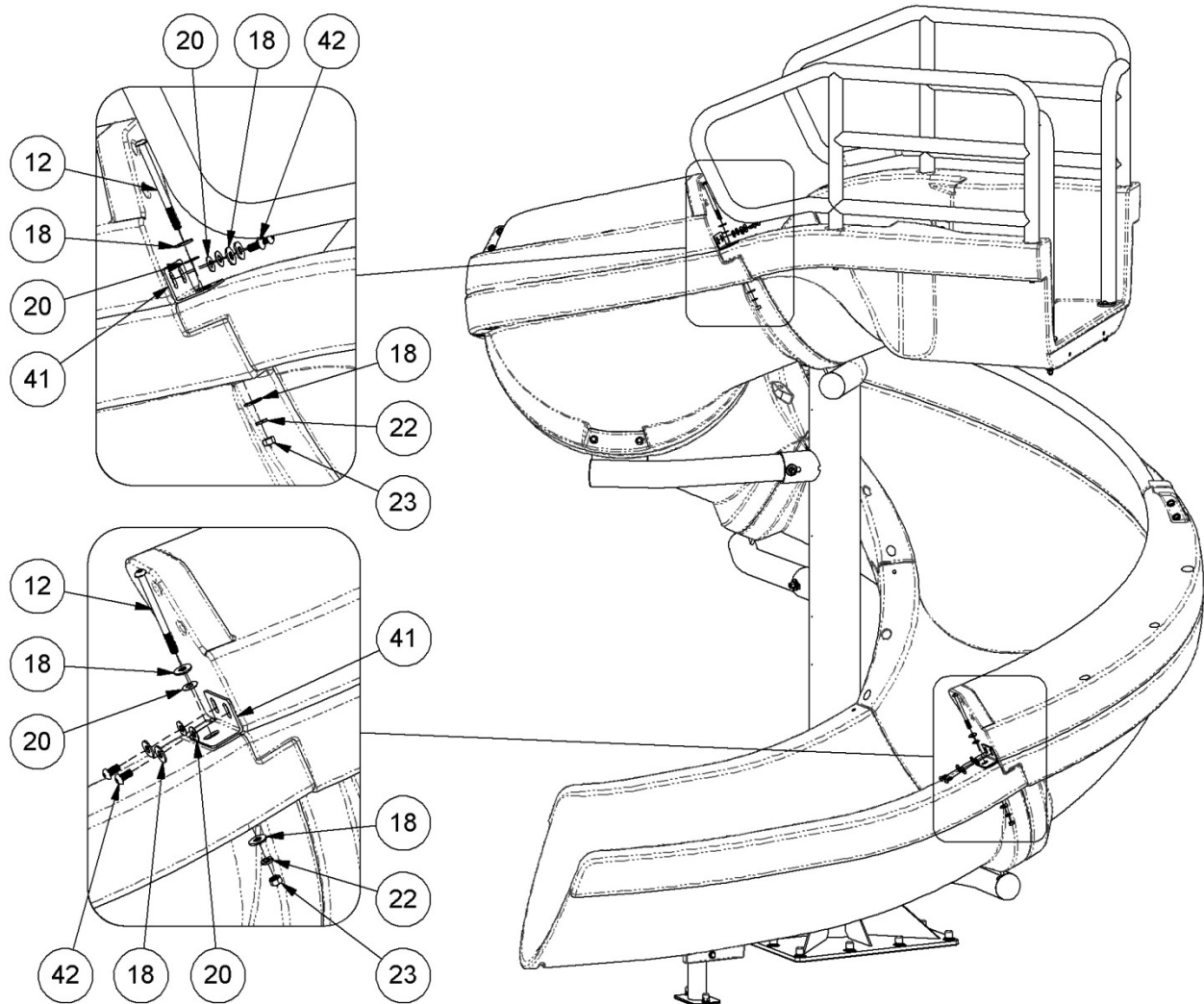

FIGURE O

- Working from the top to bottom, fasten the Risers to the Runway Flumes along the outside edge as shown in Figure P.

The required hardware is as follows: 1-1/4" Plastic Plug (74), 3/8"-16 x 5" Button Head Cap Screw S/S (12), 3/8" Flat Washer S/S (18), 3/8" Flat Washer S/S (18), 1/2" Sch. 40 PVC Spacer 3-1/4" (38), 3/8" Flat Washer S/S (18), 3/8" Lock Washer S/S (22), 3/8" Hex Nut S/S (23). Tighten the hardware until the gap in the joint is closed.

After you have started all of these bolts, you should go back through and tighten all of the fasteners installed up to this point.

Note: Be sure to apply anti-seize to all fasteners to prevent galling.

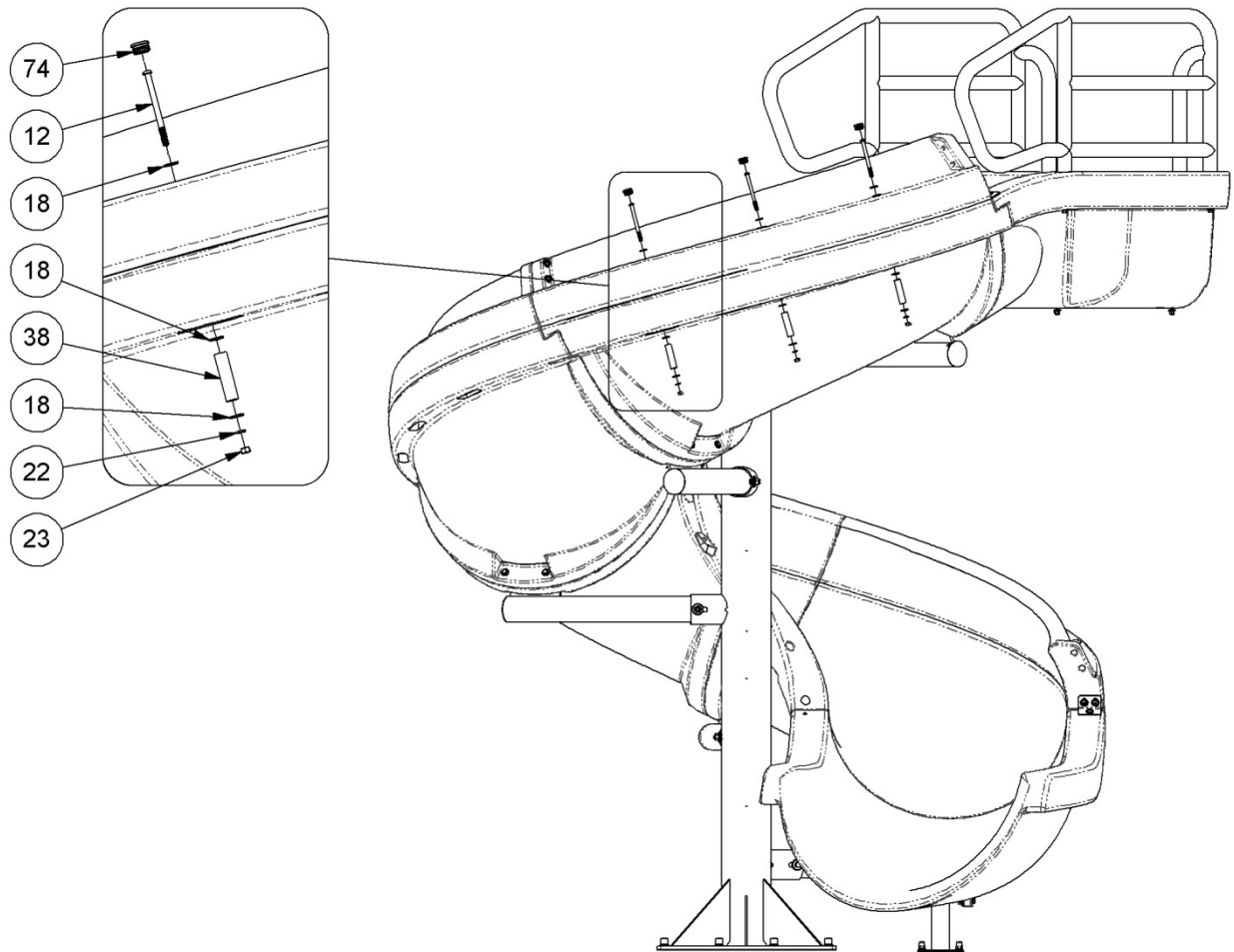
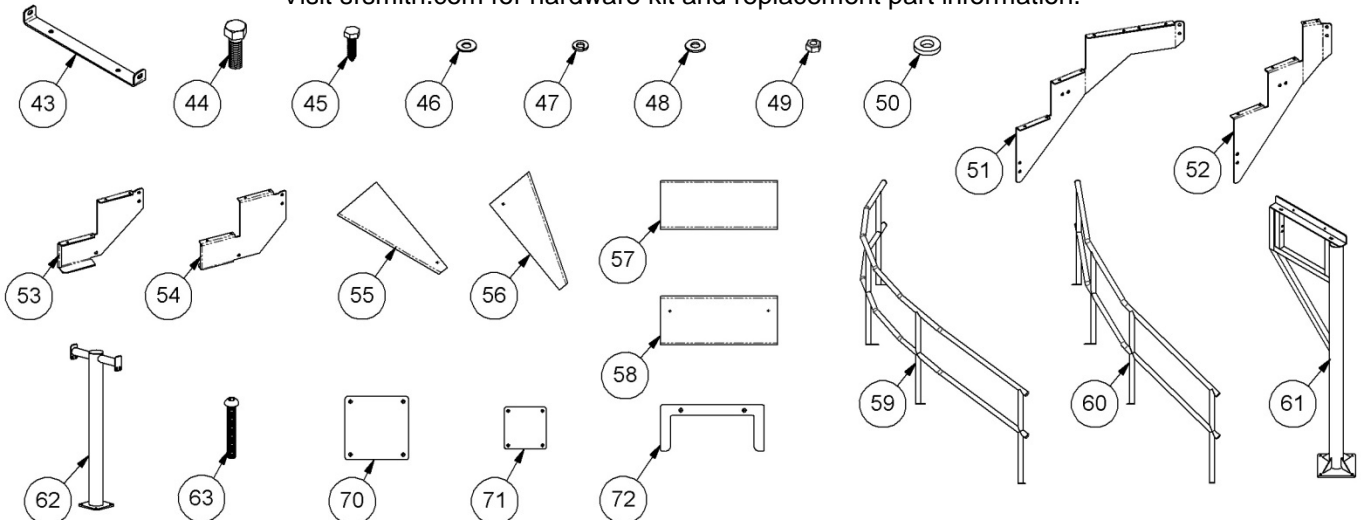

FIGURE P

VORTEX STAIRWAY PARTS LIST

ITEM NO.	PART NO.	DESCRIPTION	QTY.	KIT D
KIT D	66-209-2S	STAIRWAY HARDWARE KIT	1 ea.	
9	5-523-SS	1/2" x 3-3/4" CONC. ANCHOR WITH HARDWARE (SEE PAGE 7)	6 ea.	•
10	5-250	3/8" x 3-1/2" BHCS S/S (SEE PAGE 7)	2 ea.	
15	05-14-132	1/2" x 1-3/8" FLAT WASHER S/S (SEE PAGE 7)	44 ea.	•
16	05-14-115	1/2" LOCK WASHER S/S (SEE PAGE 7)	28 ea.	•
17	05-14-116	1/2" HEX NUT S/S (SEE PAGE 7)	22 ea.	•
19	05-616	1/2" NYLON WASHER (SEE PAGE 7)	50 ea.	•
20	05-32-111	3/8" NYLON WASHER (SEE PAGE 7)	6 ea.	•
21	5-145	3/8" x 7/8" FLAT WASHER S/S (SEE PAGE 7)	4 ea.	•
22	5-151	3/8" LOCK WASHER S/S (SEE PAGE 7)	6 ea.	•
23	5-139	3/8" HEX NUT S/S (SEE PAGE 7)	2 ea.	•
24	5-521-SS	3/8" x 3" CONC. ANCHOR WITH HARDWARE (SEE PAGE 7)	4 ea.	•
43	8-306	STEP BRACKET ANCHOR	1 ea.	
44	5-252-SS	1/2" x 1-1/2" HEX HEAD BOLT S/S	22 ea.	•
45	5-253-SS	5/16" x 1-1/4" HEX HEAD LAG SCREW S/S	42 ea.	•
46	05-625	5/16" NYLON WASHER	50 ea.	•
47	5-306	5/16" LOCK WASHER S/S	8 ea.	•
48	5-303	5/16" FLAT WASHER S/S	58 ea.	•
49	2022650	5/16" HEX NUT S/S	8 ea.	•
50	05-233	1/2" SPACER	14 ea.	
51	8-301	OUTSIDE STAIR BRACKET	3 ea.	
52	8-300	INSIDE STAIR BRACKET	3 ea.	
53	8-303	BOTTOM OUTSIDE STAIR BRACKET	1 ea.	
54	8-302	BOTTOM INSIDE STAIR BRACKET	1 ea.	
55	6-695	REAR PLATFORM STEP	3 ea.	
56	6-694	FORWARD PLATFORM STEP	3 ea.	
57	6-693	RECTANGULAR STEP W/ PILOT HOLES	7 ea.	
58	6-696	RECTANGULAR STEP W/ THROUGH HOLES	1 ea.	
59	14-305	INSIDE HANDRAIL	1 ea.	
60	14-304	OUTSIDE HANDRAIL	1 ea.	
61	14-302	MAIN STAIR SUPPORT	1 ea.	
62	14-303	MIDDLE STAIR SUPPORT	1 ea.	
63	5-257	5/16"-18 x 2-1/2" BHCS S/S	8 ea.	•
70	05-235	HDPE GASKET – MAIN STAIR SUPPORT BASE PLATE	1 ea.	
71	05-236	HDPE GASKET – MIDDLE STAIR SUPPORT BASE PLATE	1 ea.	
72	05-241	HDPE GASKET – STEP BRACKET ANCHOR PLATE	1 ea.	
75	05-618-20	1/2" NUT CAP - GRAY PLASTIC (SEE PAGE 7)	6 ea.	•
76	05-608	3/8" x 1" NUT CAP – BLACK RUBBER (SEE PAGE 7)	4 ea.	•

Visit srsmith.com for hardware kit and replacement part information.



VORTEX STAIRWAY ASSEMBLY INSTRUCTIONS

1. The nuts and washers will need to be removed from the lower guardrail connections, so the stair support angle bracket can be slipped up under the entrance flume with these screw threads feeding through the slots in the angle bracket. Move the Main Stair Support (61) into place as shown in Figure Q. Align the holes in the stair support angle bracket with the holes in the entrance section (1).
2. To ensure proper alignment of the assembly, temporarily place bolts through the mounting holes in the stair support angle bracket and the entrance section. It is also recommended that the bar clamps be used at this point to ensure that the support remains in place. Be sure that the support base plate is flat against the concrete deck. Mark the hole locations for the concrete anchors.
3. To protect the powder coat finish from damage, move the support aside before drilling the 1/2"Ø x 4" deep holes for the concrete anchors.
4. Place the support back over the holes, with the HDPE Gasket (70) between the base plate and deck. Lean the top angle bracket up against the entrance section of the slide. Then follow the instructions in on page 43 for inserting the concrete anchors into the deck.
5. Attach the following hardware to the concrete anchors (9), but do not fully tighten: 1/2" Nylon Washer (19), 1/2" Flat Washer (9), 1/2" Lock Washer (16), and a 1/2"-13 Hex Nut (9).

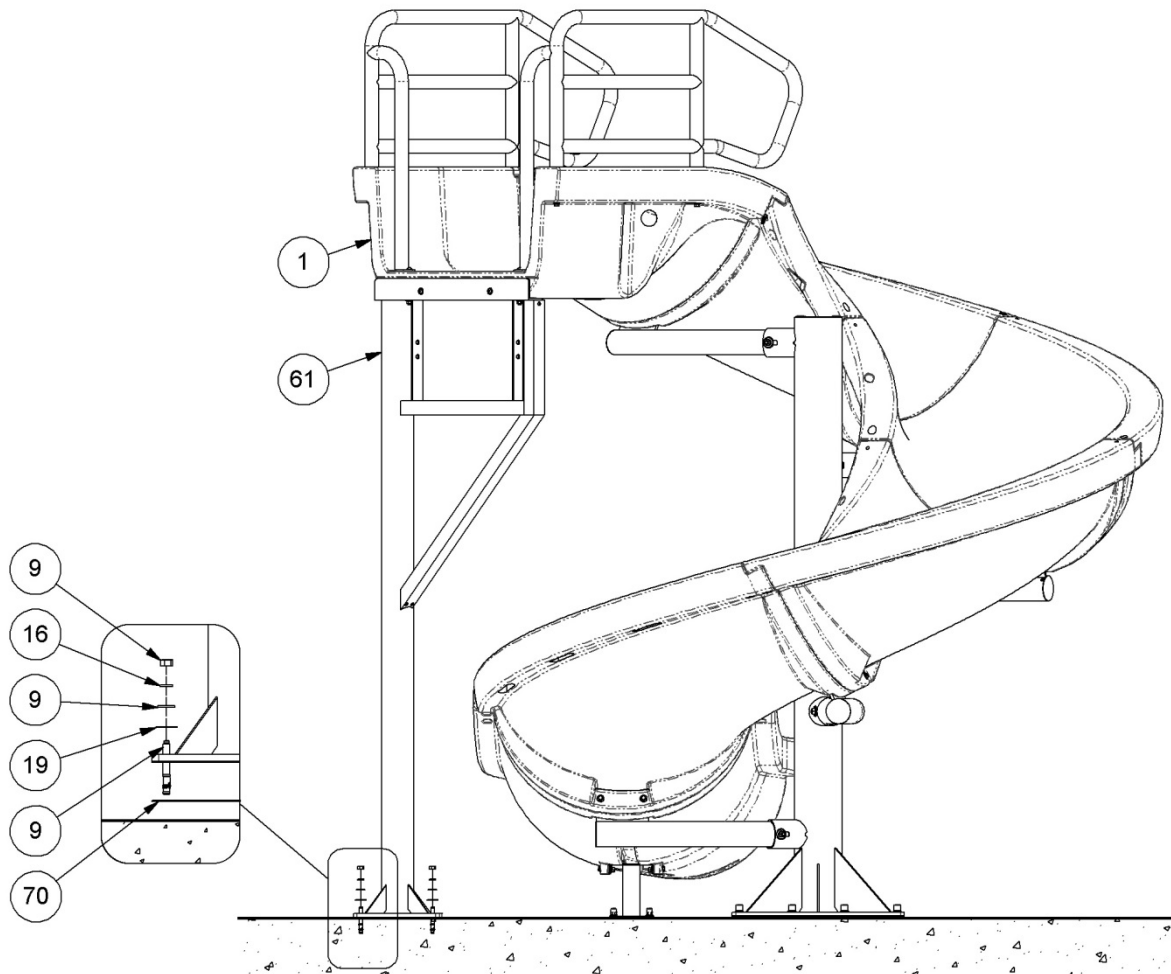

FIGURE Q

6. Install the hardware through the holes on the front face of the Main Stair Support angle bracket (61) and the Entrance Flume (1), See Figure R.

The required hardware is as follows: 3/8" x 3-1/2" Button Head Cap Screw (10), 3/8" Flat Washer (21), 3/8" Nylon Washer (20), 3/8" Flat Washer (21), 3/8" Lock Washer (22), 3/8" Hex Nut (23). This should be done for both sides of the support. After this connection is completed, finish tightening down the concrete anchor hardware at the base of the support.

7. Replace the nuts and washers previously removed from the lower guardrail brackets.

Note: Be sure to apply anti-seize to all fasteners to prevent galling.

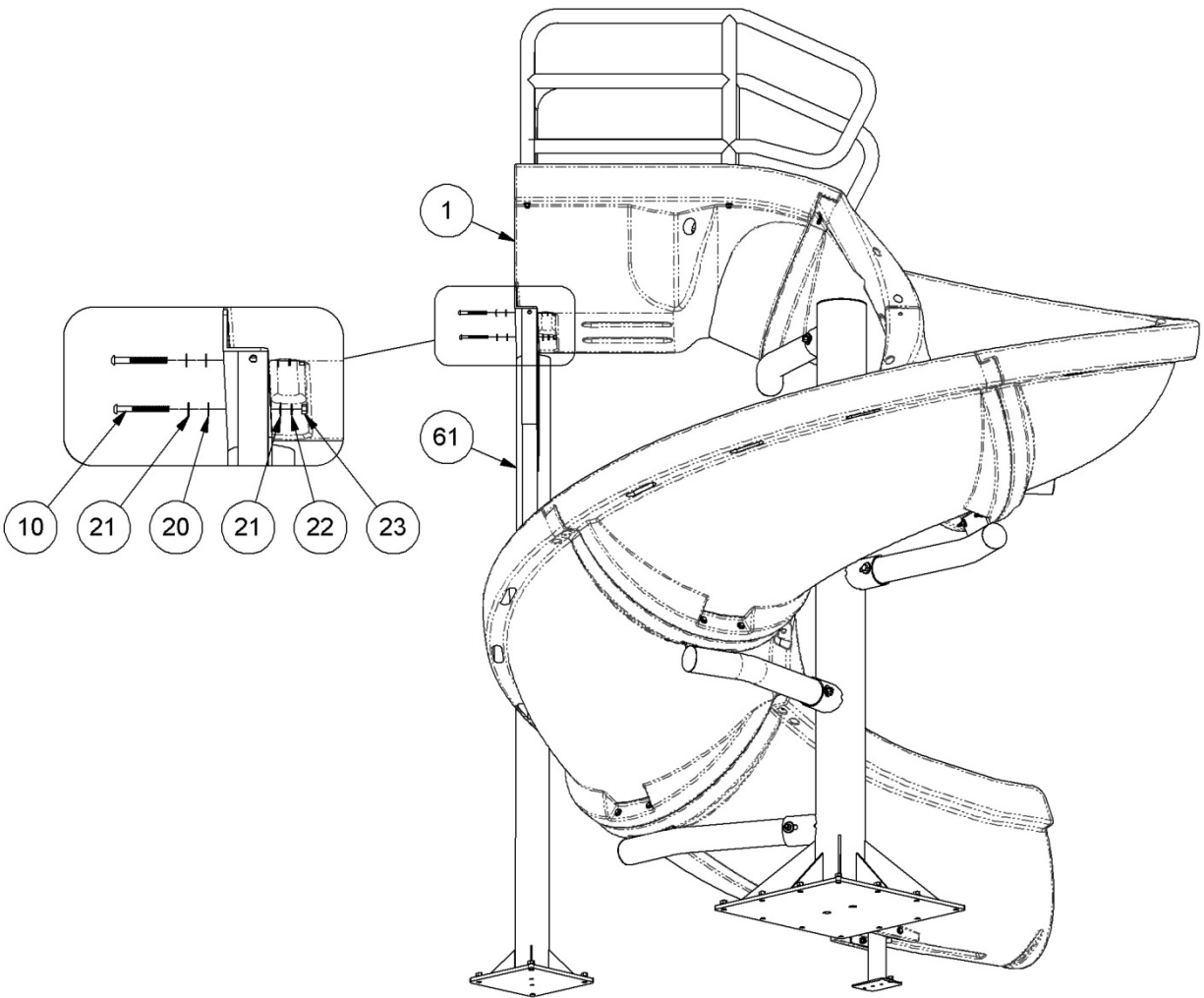

FIGURE R

- Place the Outside Stair Bracket (51) in line with the two holes on the inside of the Main Stair Support Angle Bracket so that it is closest to the support tube. See Figure S.

Use the following hardware to attach the bracket to the main stair support: 1/2" x 1-1/2" Hex Head Bolt (44), 1/2" Flat Washer (15), 1/2" Nylon Washer (19), 1/2" Nylon Washer (19), 1/2" Flat Washer (15), 1/2" Lock Washer (16), and a 1/2" Hex Nut (17), see Figure S.

Note: Do not fully tighten fasteners until after installing the handrails.

- Place the Inside Stair Bracket (52) on the inside of the Main Stair Support and repeat the steps to mount it securely to the slide as shown in Figure S.
- Add another set of side brackets and use the same hardware to fasten them. See Figure T for proper alignment and placement.

Note: Be sure to apply anti-seize to all fasteners to prevent galling.

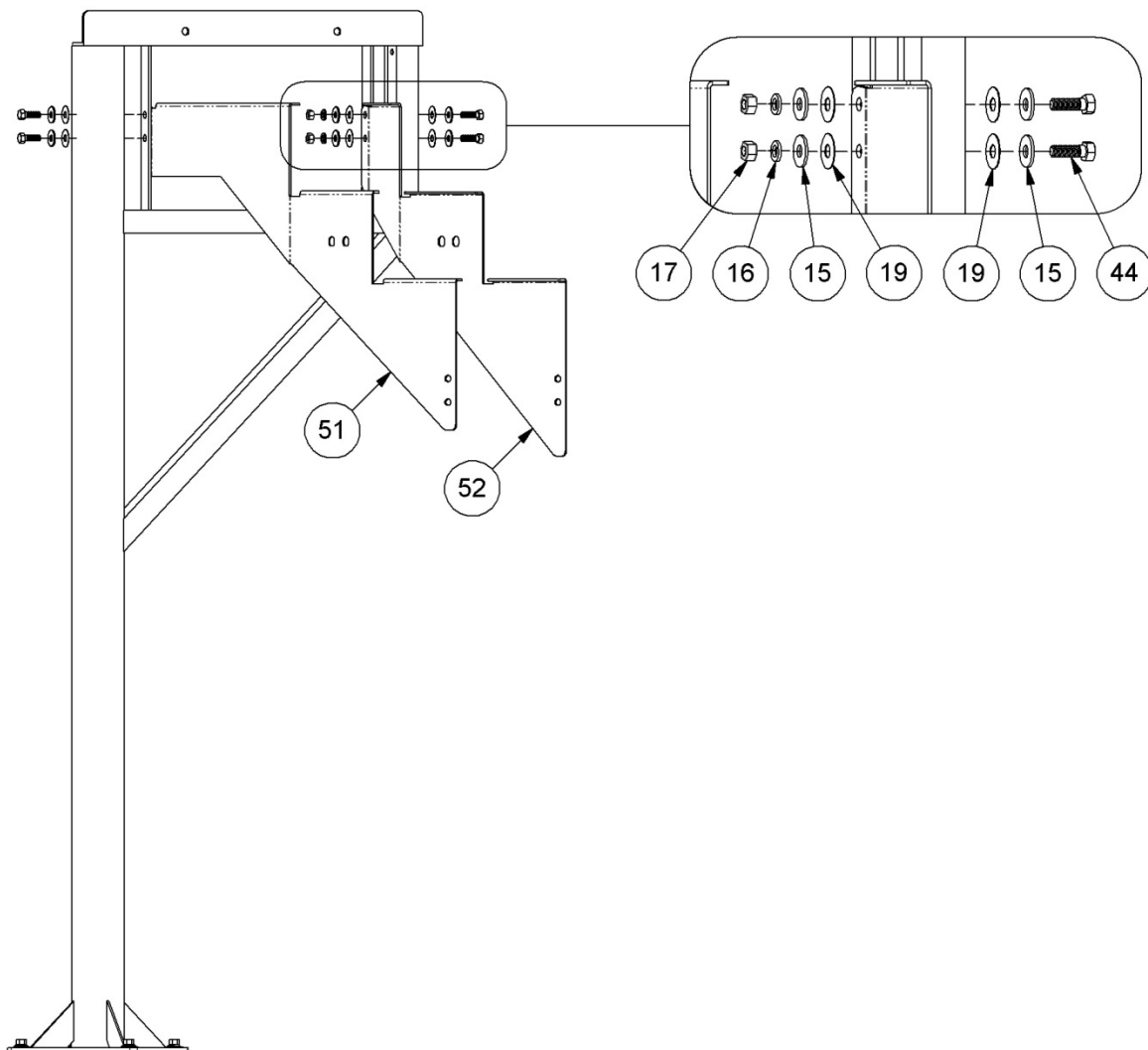

FIGURE S

11. Move the Middle Stair Support (62) into place as shown in Figure T. Align the holes in the Middle Stair Support bracket with the holes in the stair brackets.
12. Attach both sides of the Middle Stair Support to the stair brackets as shown in Figure T. The required hardware is as follows: 1/2" x 1-1/2" Hex Head Bolt (44), 1/2" Flat Washer (15), 1/2" Nylon Washer (19), 1/2" Flat Washer (15), 1/2" Lock Washer (16), 1/2" Hex Nut (17).
13. Add another set of side brackets and use the same hardware as shown in Figure S to fasten them.

Note: Be sure to apply anti-seize to all fasteners to prevent galling.

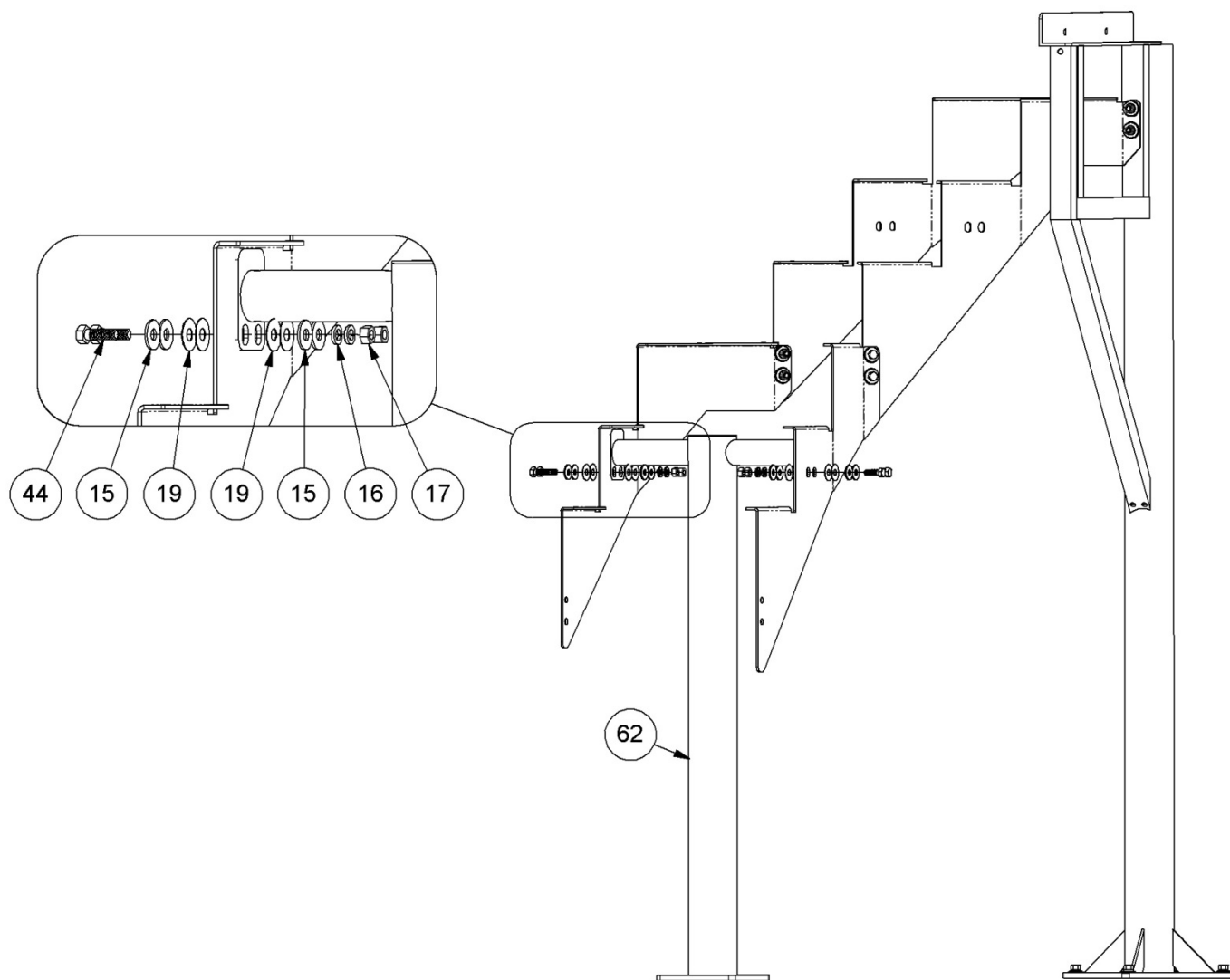

FIGURE T

- Place the bottom outside Stair Bracket (53) in line with the two holes on the outside Stair Bracket so that it is inside the stair bracket, as shown in Figure U.

Use the following hardware to attach the bracket to the Main Stair Support: 1/2" x 1-1/2" Hex Head Bolt (44), 1/2" Flat Washer (15), 1/2" Nylon Washer (19), 1/2" Nylon Washer (19), 1/2" Flat Washer (15), 1/2" Lock Washer (16), and a 1/2" Hex Nut (17).

Note: Do not fully tighten fasteners until after installing the handrails.

- Finally, place the bottom inside Stair Bracket (54) on the outside of the previous bracket and repeat the steps above to secure it to the stair assembly.

Note: Be sure to apply anti-seize to all fasteners to prevent galling.

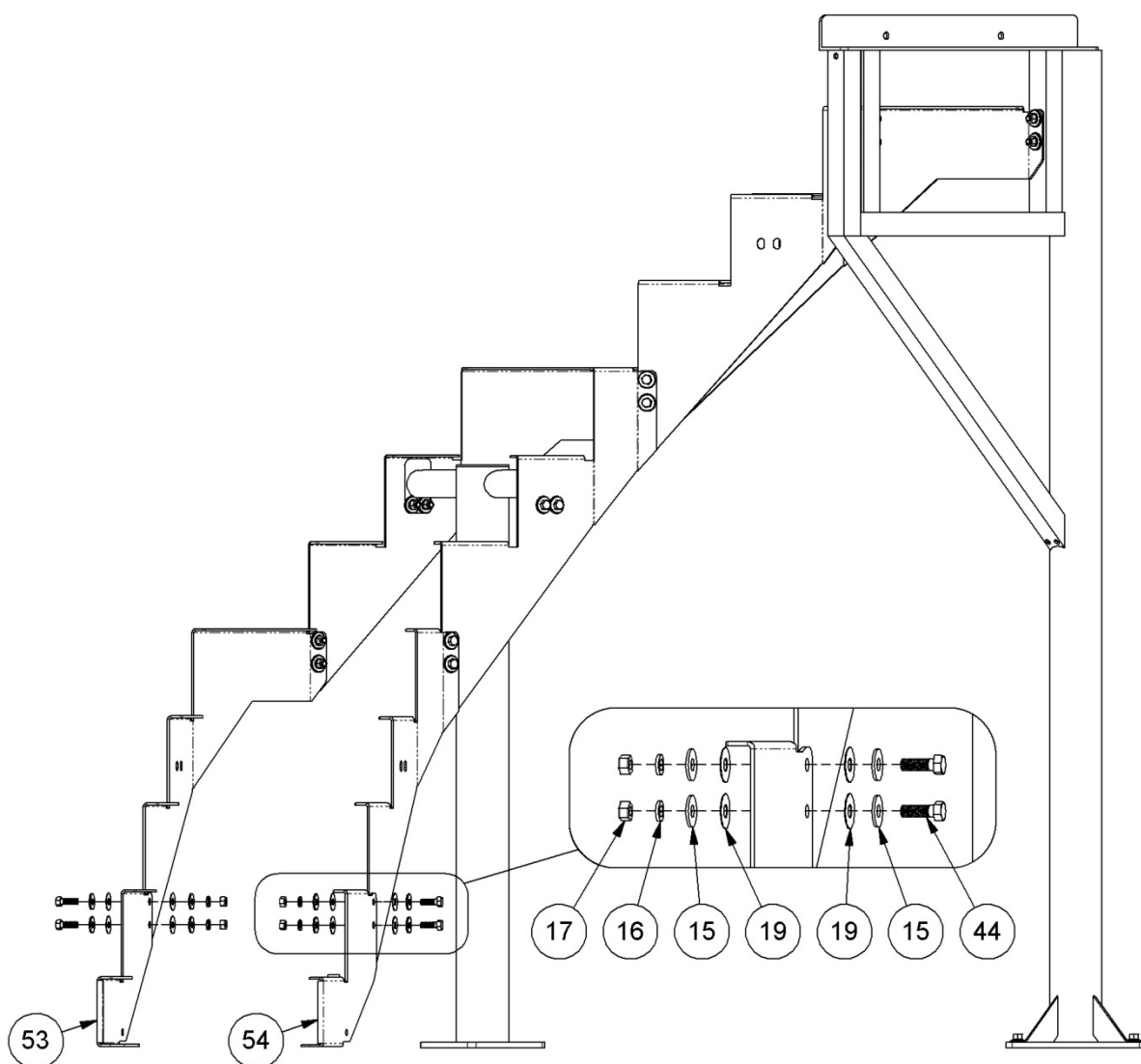

FIGURE U

16. Place the Step Bracket Anchor (43) inside the two Bottom Stair Brackets and align the holes in the flanges as shown in Figure V.

Use the following hardware to attach both sides of the Step Bracket Anchor (43) to the Bottom Stair Brackets: 1/2" x 1-1/2" Hex Head Bolt (44), 1/2" Flat Washer (15), 1/2" Nylon Washer (19), 1/2" Nylon Washer (19), 1/2" Flat Washer (15), 1/2" Lock Washer (16), and a 1/2" Hex Nut (17).

Note: Do not fully tighten fasteners until after installing the handrails.

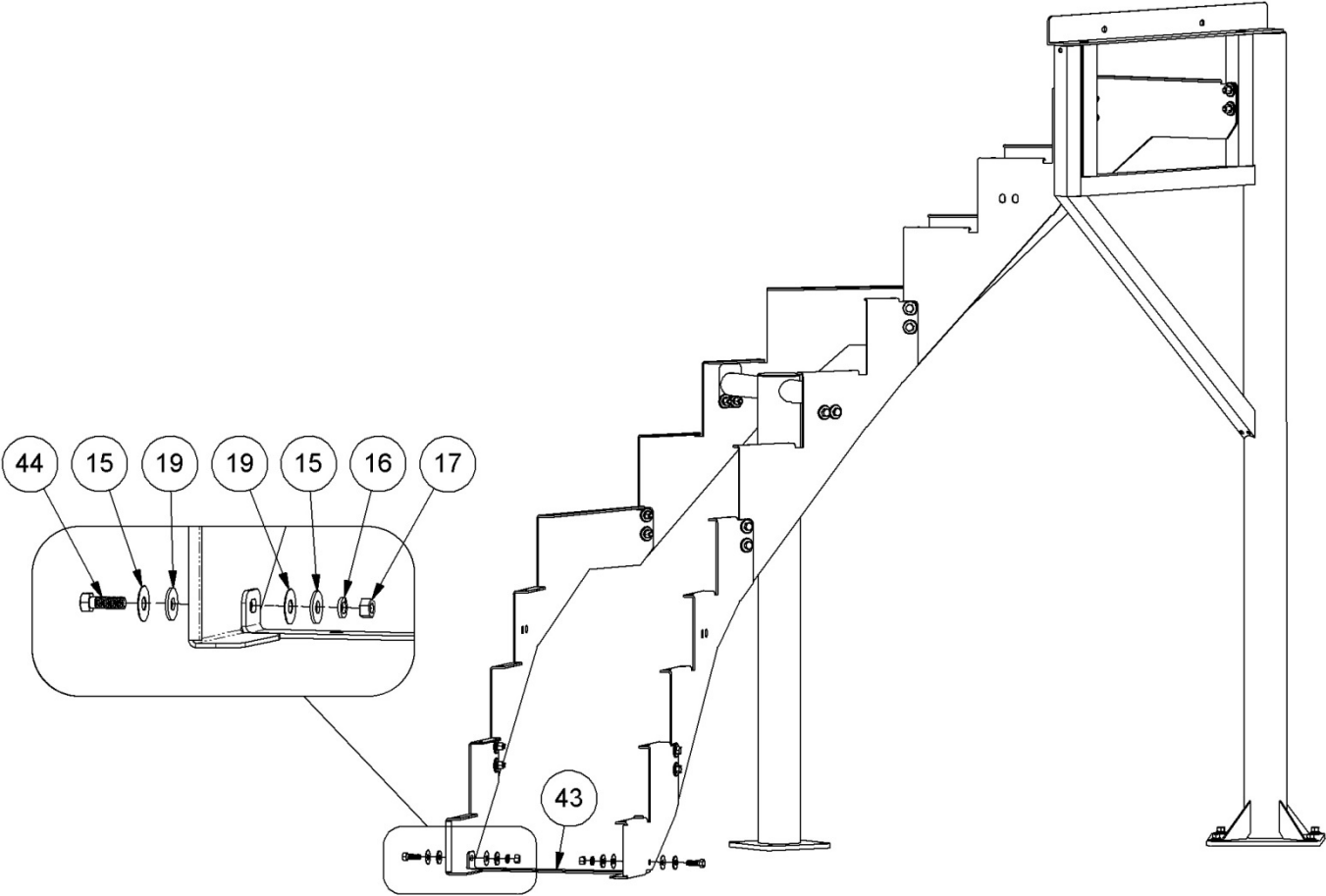

FIGURE V

17. Install Stair Steps (57) on all of the steps except for the ones where handrail brackets will be attached. Align the pre-drilled pilot holes in the Stair Steps (57) with the holes on each side of the stair brackets as shown in Figure W.

Use the following hardware to attach the Stair Steps (57) to the brackets: 5/16" x 1-1/4" Hex Head Lag Screw (45), 5/16" Flat Washer (48), and a 5/16" Nylon Washer (46).

Note: Be sure to apply anti-seize to all fasteners to prevent galling.

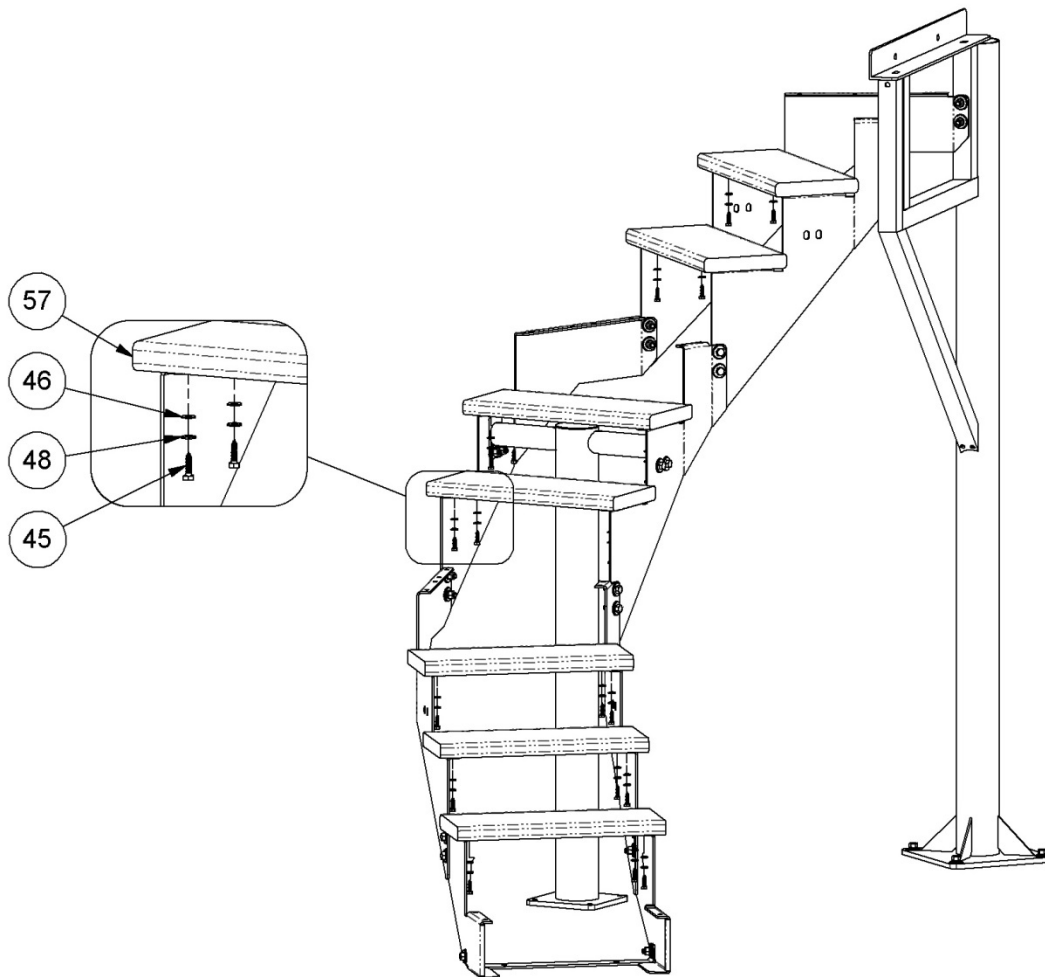

FIGURE W

18. Install the handrails using enough hardware to hold them in place. Make sure that the Step Bracket Anchor (43) and the base plate of the Middle Stair Support (62) are flat against the concrete deck.
19. Mark the hole locations for the concrete anchors. Unfasten the stair assembly from the Main Stair Support (61), and move it aside. Drill 1/2"Ø x 4" deep holes for the Step Bracket Anchor (43), and 3/8"Ø x 4" deep holes for the concrete anchors for the Middle Stair Support (62). Move the stair assembly back into place, with the HDPE Gaskets (71) and (72) between the base plates and deck. Then reattach it to the Main Stair Support (61) and then follow the instructions on page 43 for inserting concrete anchors into the deck.

The required hardware for the Step Anchor Bracket (43) is as follows: 1/2" Wedge Anchor with hardware (9), 1/2" Nylon Washer (19), 1/2" Lock Washer (16).

For order of assembly see Figure X.

The required hardware for the Middle Stair Support (62) is as follows: 3/8" Wedge Anchor with hardware (24), 3/8" Nylon Washer (20), 3/8" Lock Washer (22).

For order of assembly, see Figure X.

Note: Do not fully tighten the concrete anchors yet.

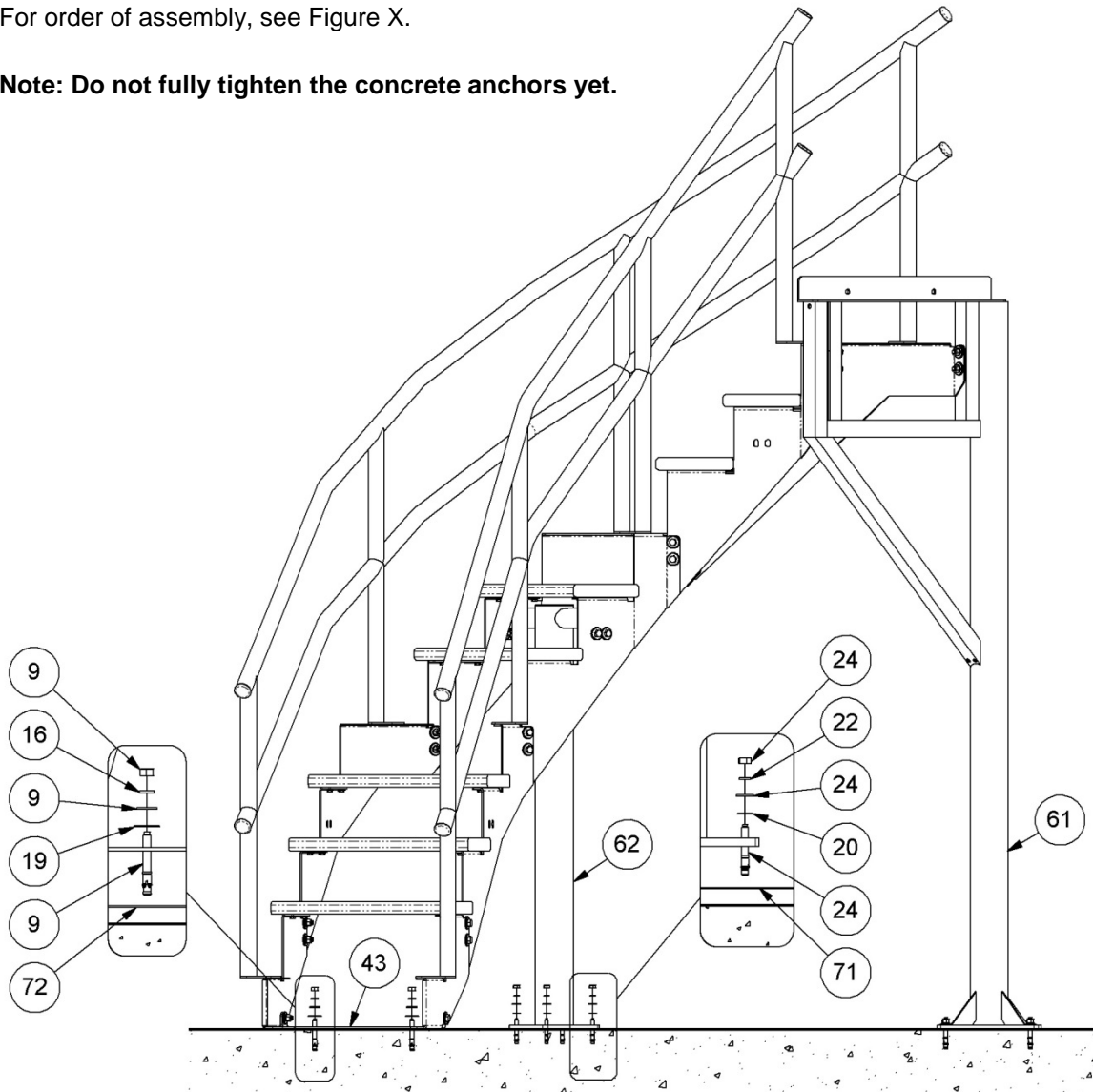

FIGURE X

20. Install the Platform Steps (55 and 56) and the Bottom Step (58).

Use the following hardware to attach the stair steps through the Handrail brackets: 5/16" x 2-1/2" Socket Head Cap Screw (63), 5/16" Flat Washer (48), 5/16" Nylon Washer (46), 5/16" Flat Washer (48), 5/16" Lock Washer (47), and a 5/16" Hex Nut (49), see Figure Y.

Use the following hardware to attach the stair steps where there are not Handrail Brackets: 5/16" x 1-1/4" Hex Head Lag Screw (45), 5/16" Flat Washer (48), and a 5/16" Nylon Washer (46), and a 1/2" Spacer (50). See Figure Y.

21. After all stairway hardware has been attached, go through and make sure that all the hardware is tightened securely. Once all the hardware is tight, install 1/2" Nut Caps (75) on the 1/2" Concrete Anchors and 3/8" Nut Caps (76) on the 3/8" Concrete Anchors.

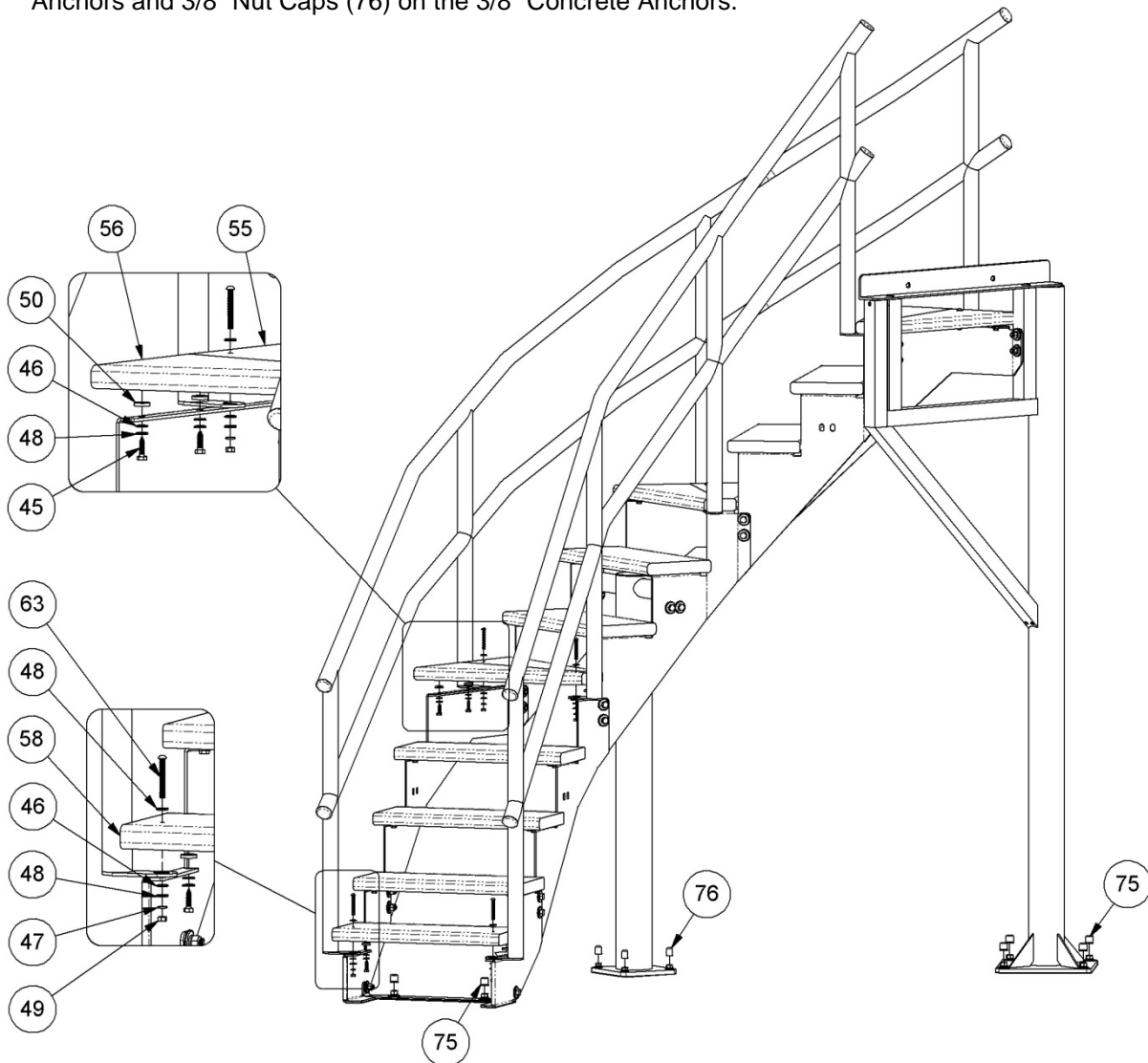
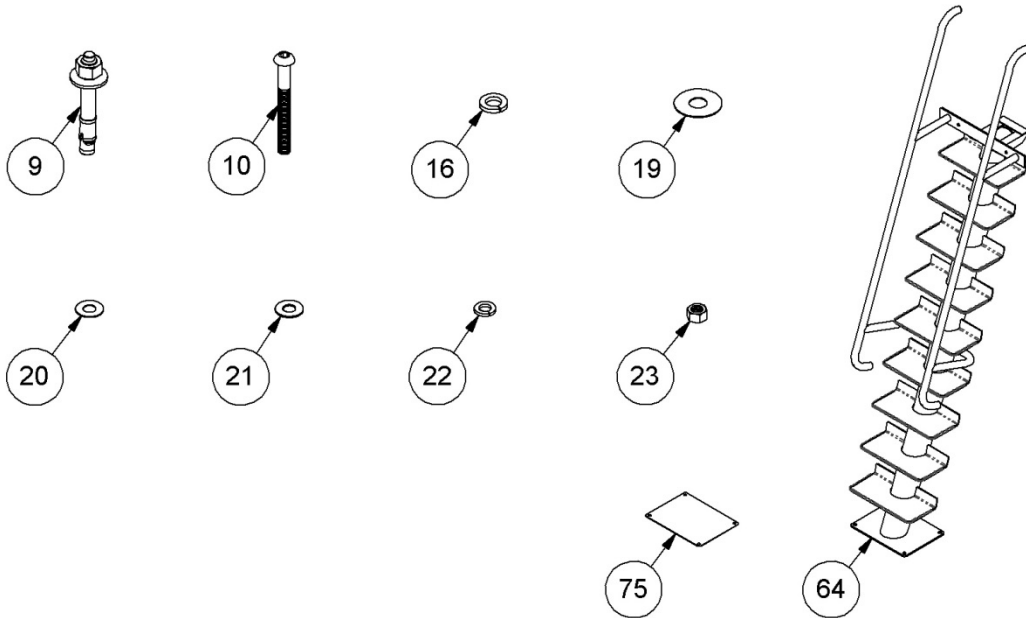

FIGURE Y

VORTEX LADDER PARTS LIST

ITEM NO.	PART NO.	DESCRIPTION	QTY.
9	5-523-SS	1/2" x 3-3/4" CONC. ANCHOR WITH HARDWARE	4 ea.
10	5-250	3/8" x 3-1/2" BHCS S/S	2 ea.
16	05-14-115	1/2" LOCK WASHER S/S	4 ea.
19	05-616	1/2" NYLON WASHER	4 ea.
20	05-32-111	3/8" NYLON WASHER	2 ea.
21	5-145	3/8" x 7/8" FLAT WASHER S/S	4 ea.
22	5-151	3/8" LOCK WASHER S/S	2 ea.
23	5-139	3/8" HEX NUT S/S	2 ea.
64	14-209	LADDER	1 ea.
73	05-238	HDPE GASKET – LADDER BASE PLATE	1 ea.
75	05-618-20	1/2" NUT CAP - GRAY PLASTIC (SEE PAGE 7)	4 ea.

Visit srsmith.com for hardware kit and replacement part information.



VORTEX LADDER ASSEMBLY INSTRUCTIONS

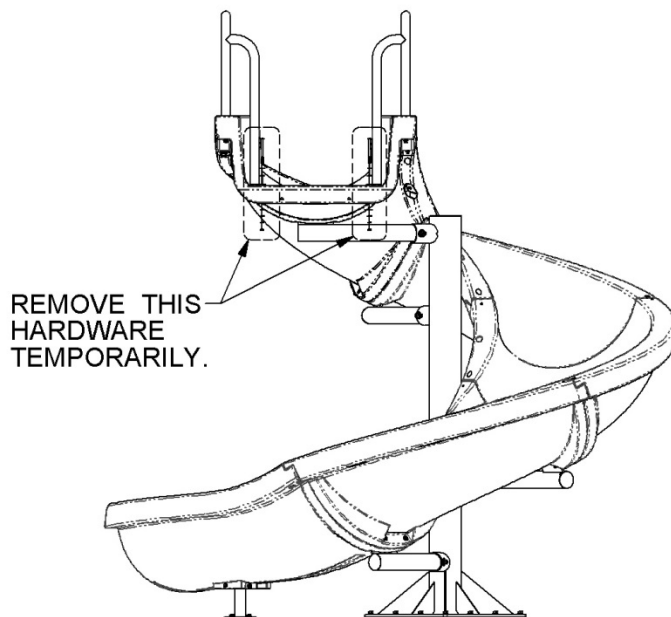

FIGURE Z

1. Move the Ladder (64) into place as shown in Figure AA. Align the holes in the ladder angle bracket with the holes in the entrance section. To ensure proper alignment of the assembly, temporarily place bolts through the mounting holes in the ladder and the entrance section. It is recommended that the bar clamps be used at this point to ensure that the ladder remains in place.
2. With the mounting plate flat against the concrete deck, mark the hole locations for the Ladder's (64) concrete anchors.

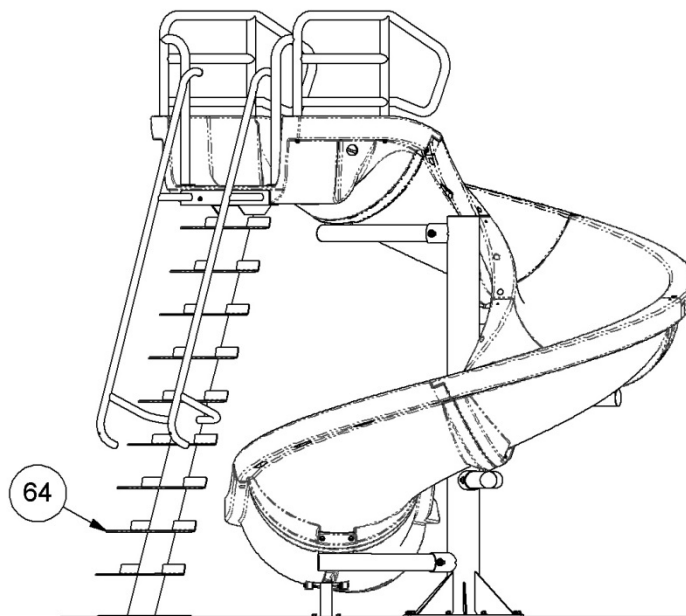

FIGURE AA

3. Move the ladder aside, before drilling the 1/2"Ø x 4" deep holes for the concrete anchors.
4. Move the ladder back over the holes and against the entrance section of the slide, with the HDPE Gasket (73) between the base plate and deck. Then follow the instructions on page 43 for inserting the concrete anchors into the deck.

The required hardware is as follows: 1/2" Concrete Anchor with hardware (9), 1/2" Nylon Washer (19), 1/2" Lock Washer (16). For order of assembly, see Figure BB.

Note: Do not fully tighten the concrete anchors yet.

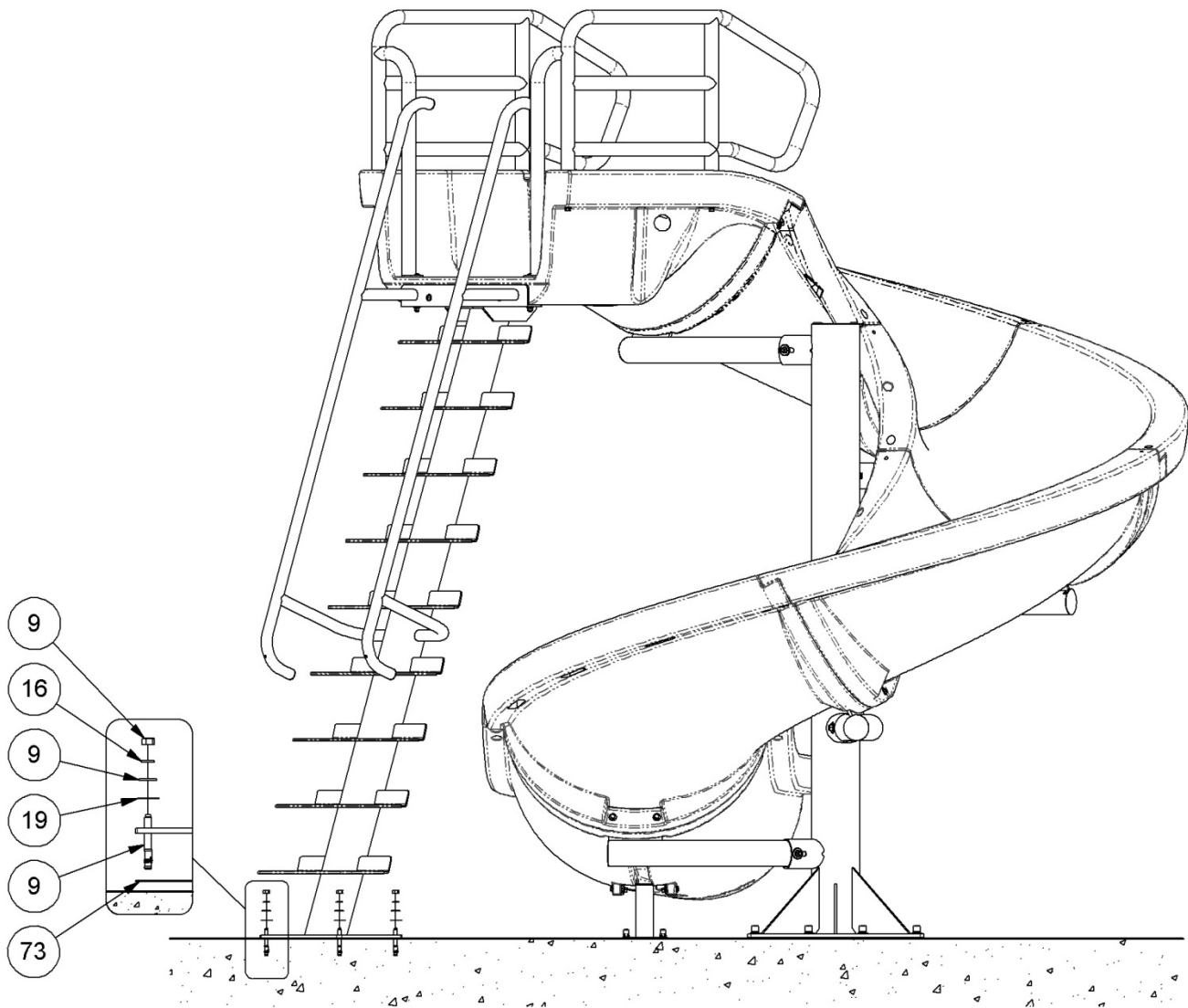

FIGURE BB

5. Fasten the hardware through the holes on the front face of the Ladder angle bracket as shown in Figure CC. The required hardware is as follows: 3/8" x 3-1/2" Button Head Cap Screw (10), 3/8" Flat Washer (24), 3/8" Nylon Washer (23), 3/8" Flat Washer (24), 3/8" Lock Washer (25), 3/8" Hex Nut (26).
6. Replace the hardware for the entrance guardrail brackets that was removed during the first step of the ladder installation.
7. After these connections are completed, finish tightening the concrete anchor hardware at the base of the ladder.
8. Once all the fasteners are tightened, install Nut Caps (76) on the concrete anchors.

Note: Be sure to apply anti-seize to all fasteners to prevent galling.

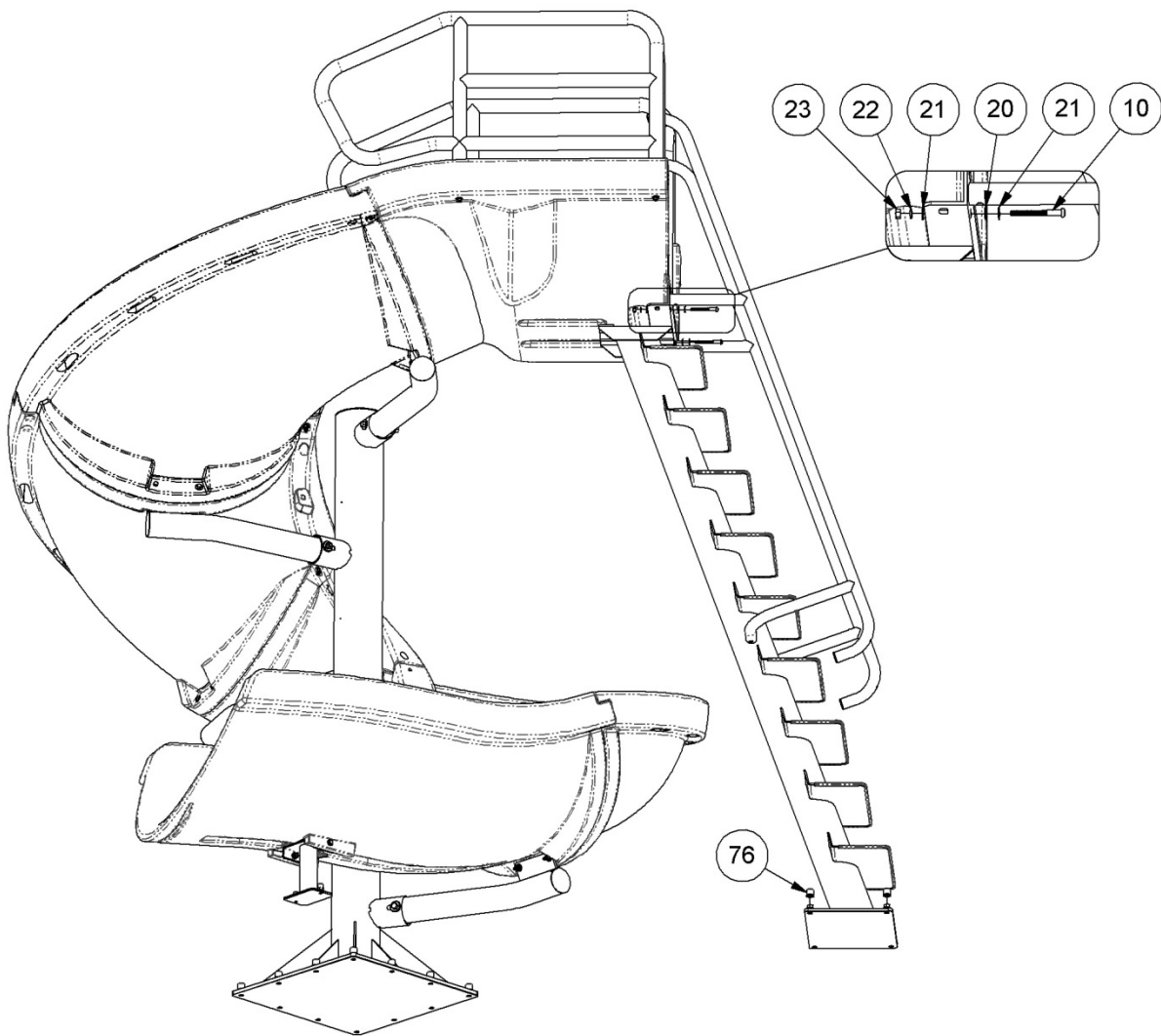

FIGURE CC

VORTEX WARNING SIGN PARTS LIST

ITEM NO.	PART NO.	DESCRIPTION	QTY.
77	05-623	SLIDE LARGE DECK FLANGE WITH HARDWARE	1 ea.
78	06-369	VORTEX SLIDE RULES SIGN (NOT SHOWN)	1 ea.
79	05-162	5/16"x 2-3/4" CONCRETE ANCHOR WITH HARDWARE	4 ea.
80	800-1110	5/16" LOCK WASHER	1 ea.
81	4-409	VORTEX WARNING SIGN POST	1 ea.

Visit srsmith.com for hardware kit and replacement part information.

VORTEX WARNING SIGN ASSEMBLY INSTRUCTIONS

1. Find a location within 2'-0" of the entrance to the slide to mount the warning sign. The warning sign must face away from the entrance in a manner that it is visible at least 10'-0" from the slide entrance.
2. Use the Deck Flange (77) as a template to mark the location of the warning sign anchors.
3. Move the sign aside, and drill 5/16"Ø x 3" deep holes into the deck.
4. Move the sign back into place and install the concrete anchors in accordance with the instructions on page 43.

The following hardware is required for mounting the Warning Sign (78) anchors: 5/16"Ø x 2-3/4" Concrete Anchors (79) and a 5/16"Ø Lock Washer (80). See Figure DD for order of assembly.

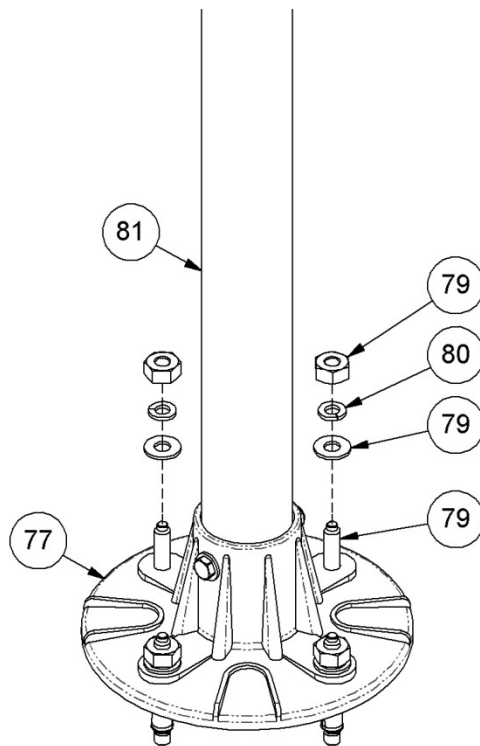
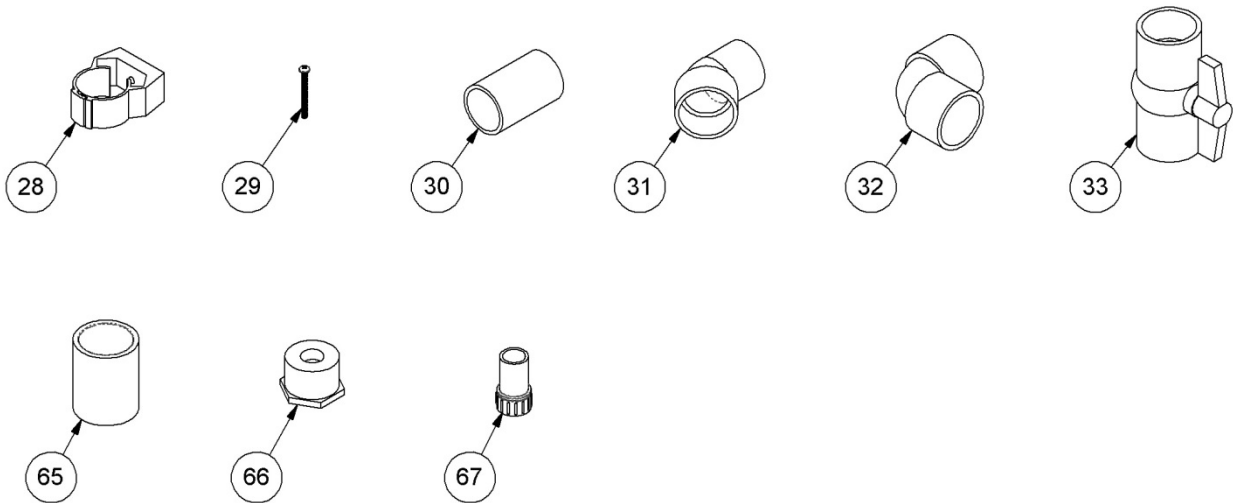

FIGURE DD

VORTEX WATER SYSTEM PARTS LIST

Item Number	Description	Quantity
28	1-1/2"Ø "CLIC TOP" PIPE CLAMP	5 ea.
29	#10-32 x 2" PANHEAD SCREW (PRE-INSTALLED IN MAIN SUPPORT)	5 ea.
30	1-1/2"Ø x 3" SCH 80 PIPE	1 ea.
31	1-1/2"Ø 45° SCH 80 ELBOW	1 ea.
32	1-1/2"Ø 90° SCH 80 ELBOW	1 ea.
33	1-1/2"Ø PVC BALL VALVE	1 ea.
34	1-1/2"Ø PVC FLEX HOSE 6'-0" LENGTH (NOT SHOWN)	2 ea.
65	1-1/2"Ø COUPLING	1 ea.
66	1-1/2"Ø x 3/4"Ø REDUCER	1 ea.
67	GARDEN HOSE ADAPTER	1 ea.

Visit srsmith.com for hardware kit and replacement part information.



WATER SYSTEM ASSEMBLY INSTRUCTIONS

1. Attach the 1-1/2"Ø Pipe Clamps (28) to the Main Support Tube with #8-32 x 2" Pan Head Screws (29) as shown in Figure EE.

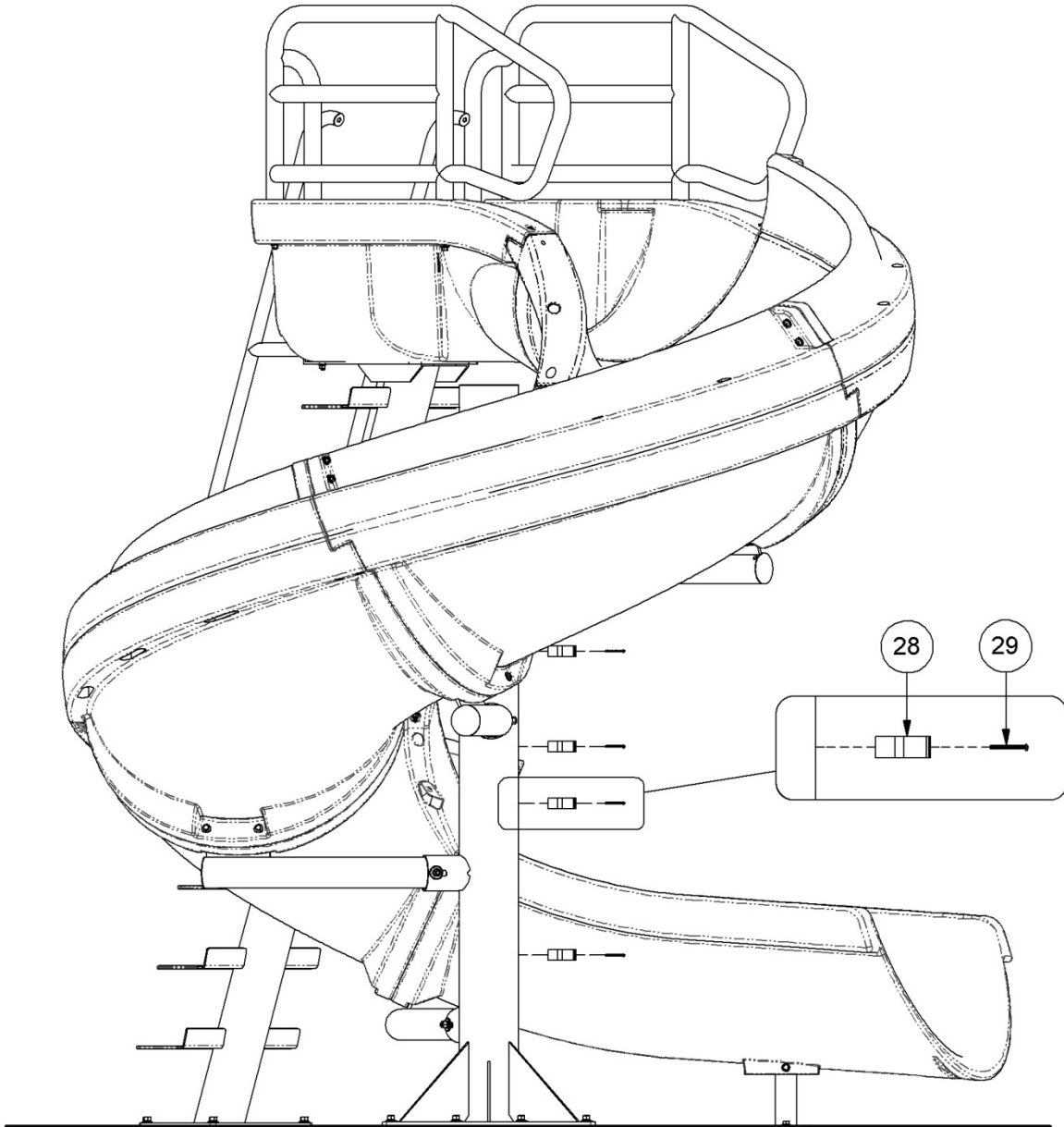

FIGURE EE

2. Assemble the three PVC components together in the order shown in Figure FF. Do not glue any of the parts together at this point. The plumbing system should be fully assembled first to ensure correct orientation before the parts are glued together.
3. Slide the 1-1/2"Ø x 3" PVC Pipe (30) into the back side of the water nozzle socket in the side of the entrance section. Then assemble the 1-1/2"Ø 45° Elbow (31) and the 1-1/2"Ø 90° Elbow (32).
4. Aim the 90° Elbow (32) toward the Main Support (5) of the slide. This is where the water supply hose which will be run.

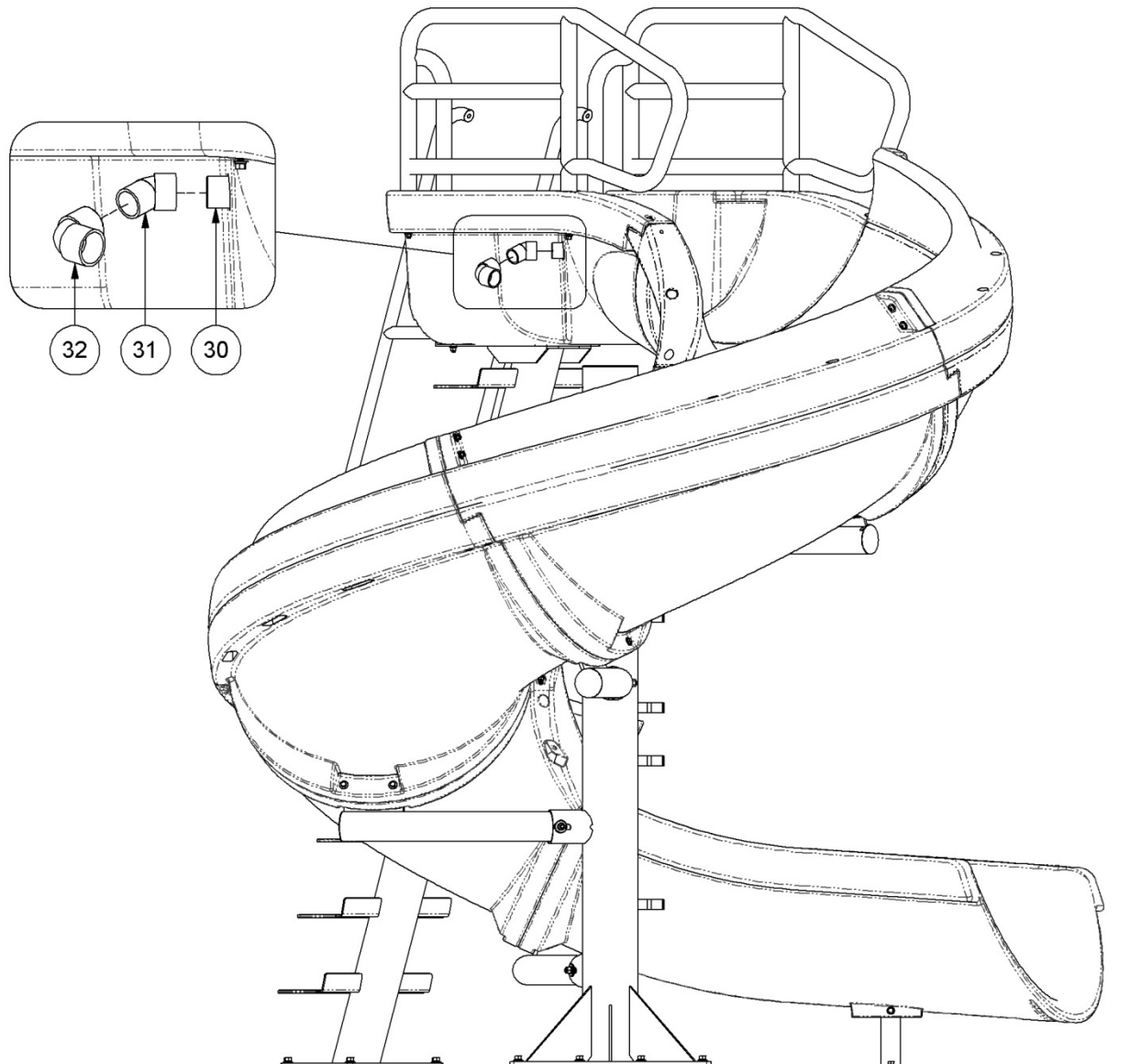

FIGURE FF

5. Connect the 1-1/2"Ø PVC Flex Hose (34) to the water supply. Then run the other end up through the lower 1-1/2"Ø Pipe Clamps (28).
6. Attach the 1-1/2"Ø PVC Ball Valve (33) as shown in Figure GG.

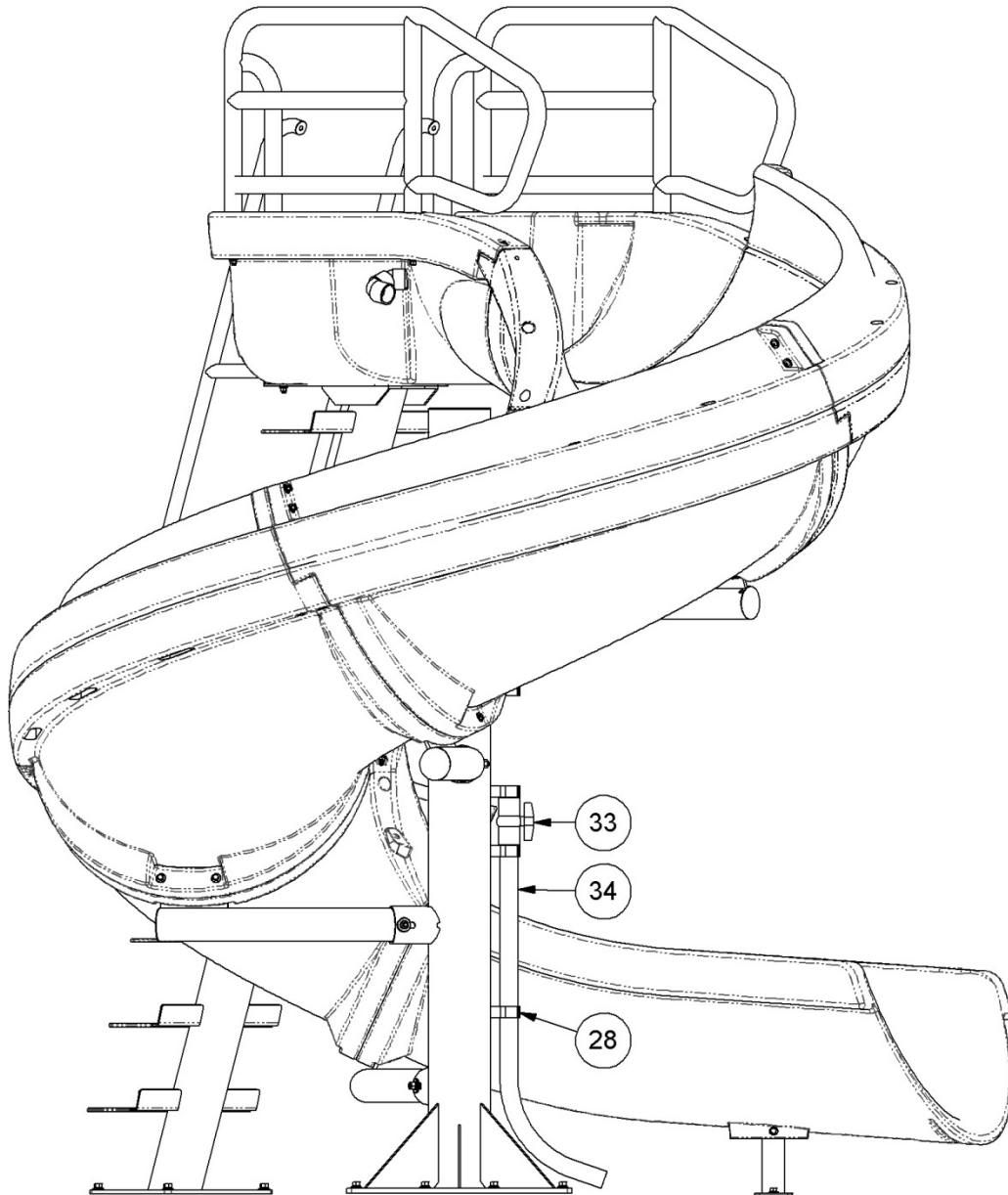

FIGURE GG

7. Attach another length of 1-1/2"Ø PVC Flex Hose (34) to the top end of the 1-1/2"Ø PVC Ball Valve (33) and run it up through the upper 1-1/2"Ø Pipe Clamps (28) to the 1-1/2"Ø 90° Elbow (32). See Figure HH.
8. When all of the connections have been made, start at the top and use PVC primer and glue to attach each connection securely. First place the primer on both surfaces that will be attached, then place the glue on the connections and slide them together. These are not provided, but can be purchased at any plumbing supply store.
9. After everything is assembled, use the Vulkem-116 Sealant (14) to fill in all of the galvanizing holes in the main section metal frame, ladder or stairway, and handrails.

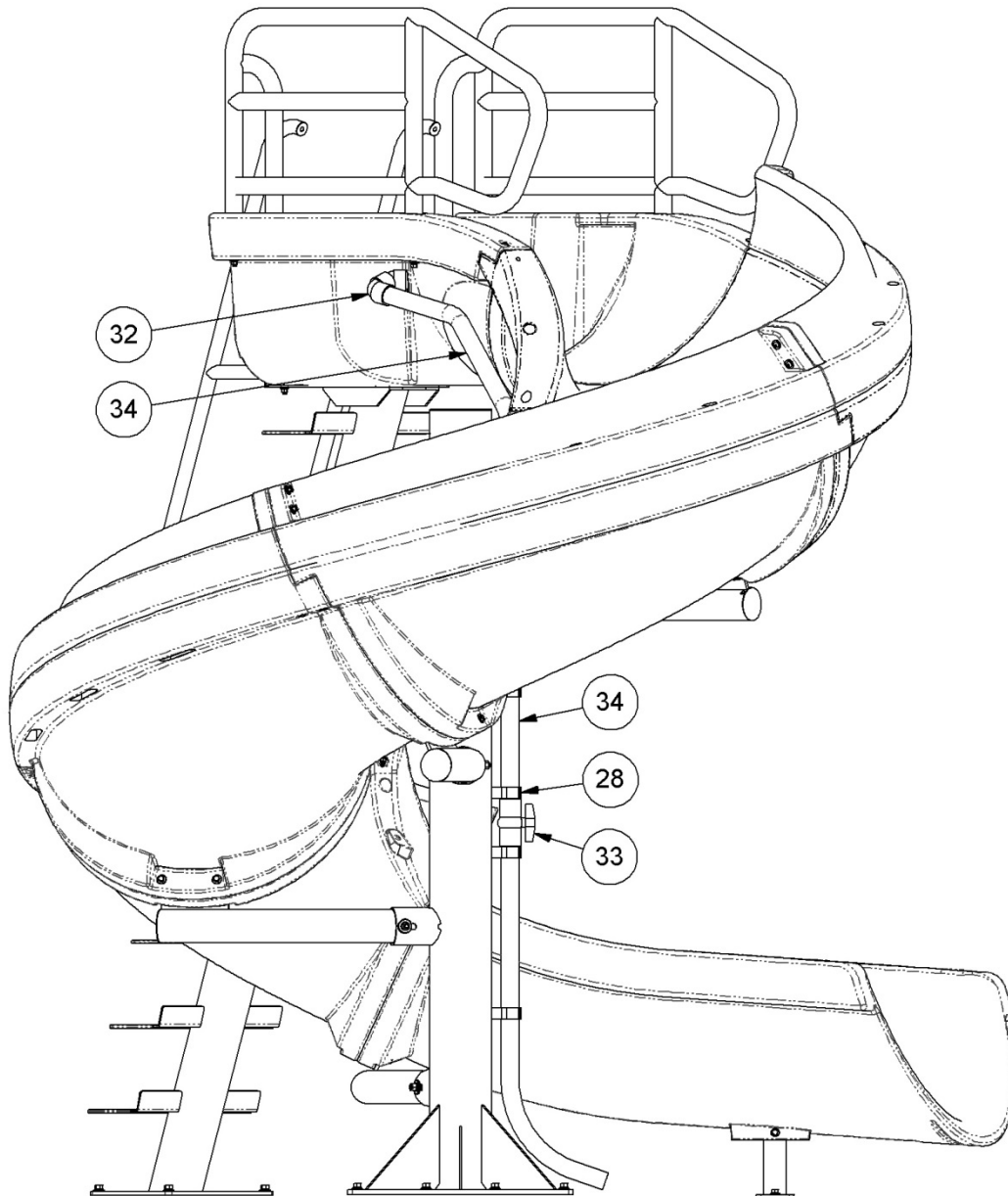

FIGURE HH

10. The Vortex is designed to connect to a 1-1/2"Ø water supply line. Plumb the water supply from the pool return line with a 1-1/2"Ø PVC pipe. Position the water supply "stub up" at the base of the slide's ladder, where the lower end of the 1-1/2"Ø Flex Hose (28) is located. The "stub up" should be installed prior to mounting the slide to the deck. The "stub up" should be dark grey PVC to match the slide's plumbing assembly. Extend the water supply "stub up" to a height of 18" above the deck. It can be cut to the desired length later, during the installation process.
11. Attach the "stub up" to the plumbing assembly installed in the slide as necessary.
12. If a garden hose is going to be used to supply water to the slide, glue the Garden Hose Adapter (66) and the 1-1/2"Ø x 3/4"Ø Reducer (65) together and then glue them into the bottom of the 1-1/2"Ø Coupler (64), as shown in Figure II.

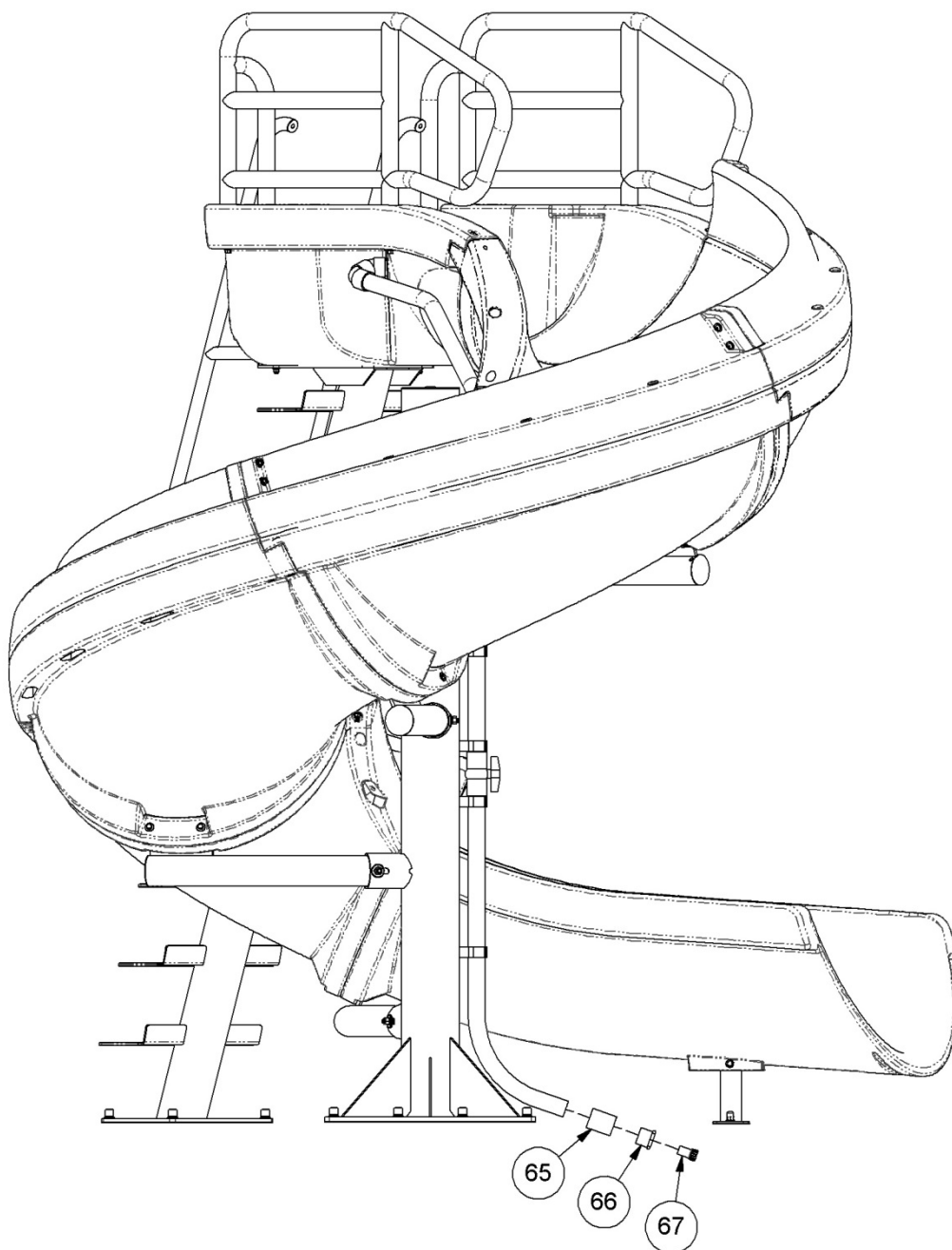

FIGURE II

CONCRETE WEDGE ANCHOR MOUNTING INSTRUCTIONS

1. Place the assembled slide on the deck relative to the pool wall. Ensure that the exit flume clears any coping. Slide may be angled slightly providing all dimensions are maintained as noted in the **“Manufacturer’s Placement Instructions”** noted on pages 44 and 45.
2. The Vortex slide must be anchored into a concrete pad that is a minimum of 8” thick.
3. With the slide in its proper location, center punch or otherwise mark through the mounting holes in the base plates so that a visible mark is apparent on the concrete.
4. In order to protect the slide from being damaged by the drill bit, move the slide aside before drilling the holes into the concrete deck.
5. Drill the holes to the required depth using a hammer drill and a concrete drill bit. Use tape or a marking on the drill bit to ensure that the hole is drilled to the required depth. Keep the drill straight and perpendicular to the deck surface while drilling in order to maintain proper holding strength of the concrete wedge anchors.
6. Clear the newly drilled holes of all debris.
7. Move the slide, stairway or ladder back into position over the holes in the concrete deck.
8. Assemble the nylon washer, flat washer, and nut so that the top of the nut is flush with the top of the wedge anchor.
9. Drive the assembled concrete wedge anchors through the slide’s mounting plate holes until the nylon washer is flush with the base plate as shown in Figure JJ.

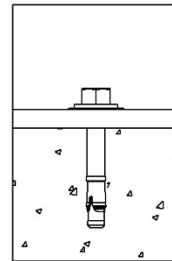

FIGURE JJ

10. Expand concrete wedge anchor by tightening the nut 3 to 5 turns.
11. When anchor is set, remove the hex nut and install a lock washer.
12. Retighten the hex nut to a torque of 25 ft.-lbs. See Figure KK for the final assembly.

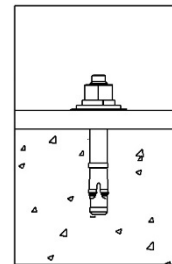

FIGURE KK

MANUFACTURER'S PLACEMENT INSTRUCTIONS

PROPER ASSEMBLY, INSTALLATION, USE, AND SUPERVISION ARE ESSENTIAL FOR PROPER OPERATION AND TO REDUCE THE RISK OF SERIOUS INJURY.

1. The critical dimensions for placement of the Vortex are as shown in Figure LL and Figure MM.
 - A. The slide exit runway surface shall not exceed 20" above the water surface as shown in Figure LL.
 - B. The slide shall be positioned so that all water flowing off the runway exit drops into the pool. The recommended overhang is 4".
 - C. The minimum depth of water below the exit lip of the slide shall be 3'-0" and increase to 4'-6" at Point A, which is a distance of 4'-6" from the exit lip of the slide as shown in Figure LL.
 - D. A minimum depth of 4'-6" shall be maintained at a distance of 9'-0" along the extended centerline of the slide from Point A. as shown in Figure LL.

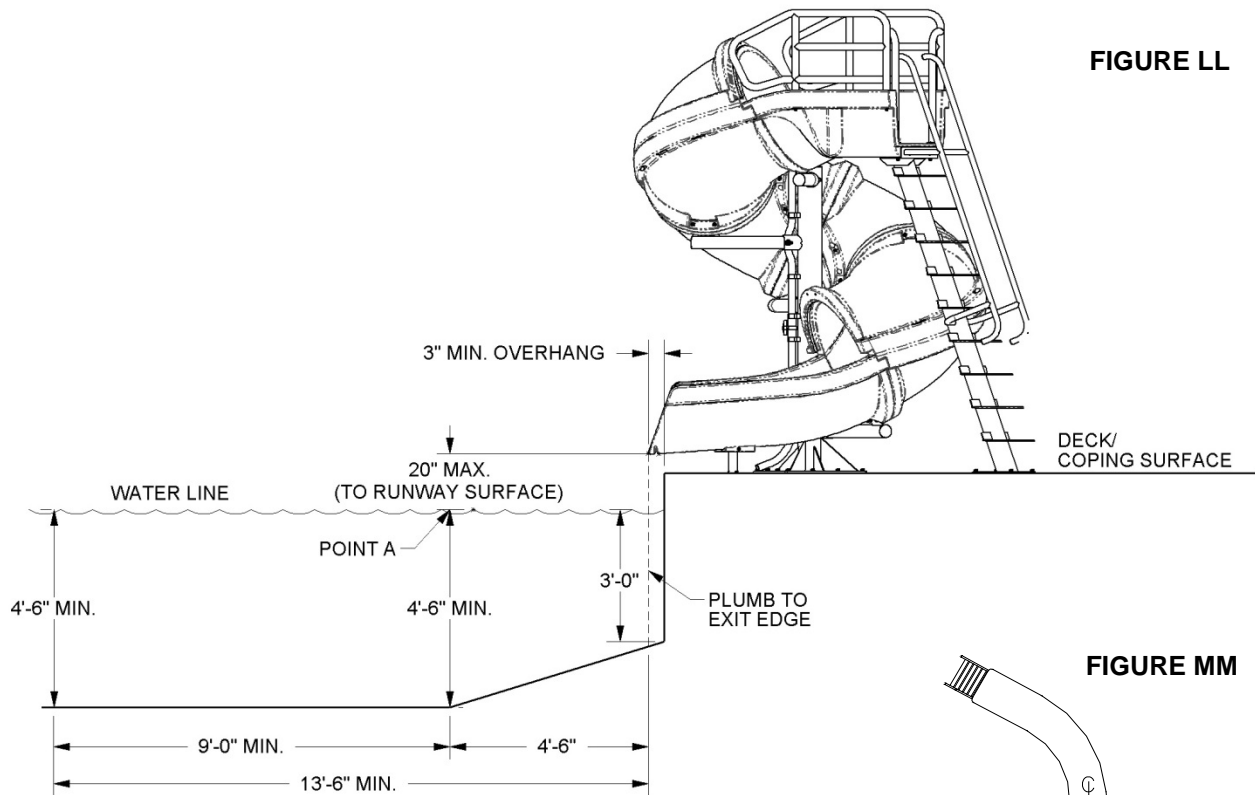

FIGURE LL

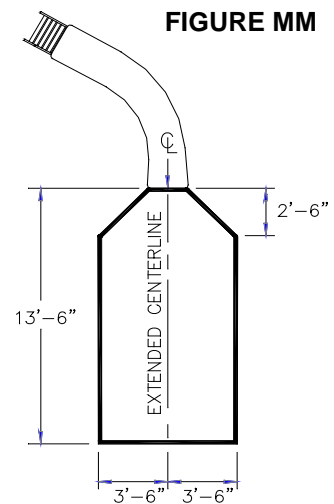

FIGURE MM

2. A minimum clearance area in front of the slide shall be maintained at all times as follows:
 - A. The minimum clearance distance on either side of the extended centerline of the slide runway shall not be less than 3'-6" at a point no less than 2'-6" from the exit lip of the slide and extending a distance of 13'-6" in front of the slide as shown in Figure MM.

SLIDE
MINIMUM CLEARANCE AREA

3. Slide placement instructions for installations on pools with other slides and / or diving boards.
 - A. The minimum clearance area in front of a properly installed diving board on an in-ground swimming pool is a minimum distance of 3'-6" on either side of the board's centerline as shown in Figure NN. (Pt. C) extends a minimum distance of (C) from the tip end of the board as shown in Figure NN. The width distance (W) on either side of (Pt. C) is given in Table 1 below.

TABLE 1

Board Minimum Clearance Area		
Pool Type	(C) Dimension	(W) Dimension
I	14'-6"	5'-0"
II	14'-6"	6'-0"
III	16'-6"	6'-0"
IV	18'-6"	7'-6"
V	21'-0"	7'-6"
VI	18'-6"	9'-0"
VII	21'-0"	10'-0"
VIII	25'-0"	11'-0"
IX	31'-6"	12'-0"

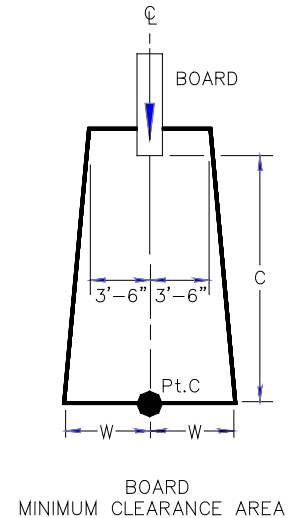

**BOARD
MINIMUM CLEARANCE AREA**

For Pool Type I-V, see Article 5.8 contained in ANSI/APSP/ICC-5 2011 STANDARD FOR RESIDENTIAL INGROUND SWIMMING POOLS and refer to Figure NN and Table 1 for Minimum Water Envelope Dimensions AB, BC and Width at Point C. For Pool Type VI-IX, see Article 6.6 in ANSI/APSP-1 2003 STANDARD FOR PUBLIC SWIMMING POOLS and refer to Minimum Dimensions for Diving Portion of Class B and C Pools.

FIGURE NN

- (C) DIMENSION FOR BOARD = AB + BC or L2 + L3
 (W) DIMENSION FOR BOARD = WIDTH AT (Pt. C)

- B. The minimum clearance area of a slide or diving board shall not intersect any coping or rope and float line as shown in Figure OO. The minimum clearance area of a slide or diving board may intersect each other provided that they are not used simultaneously.

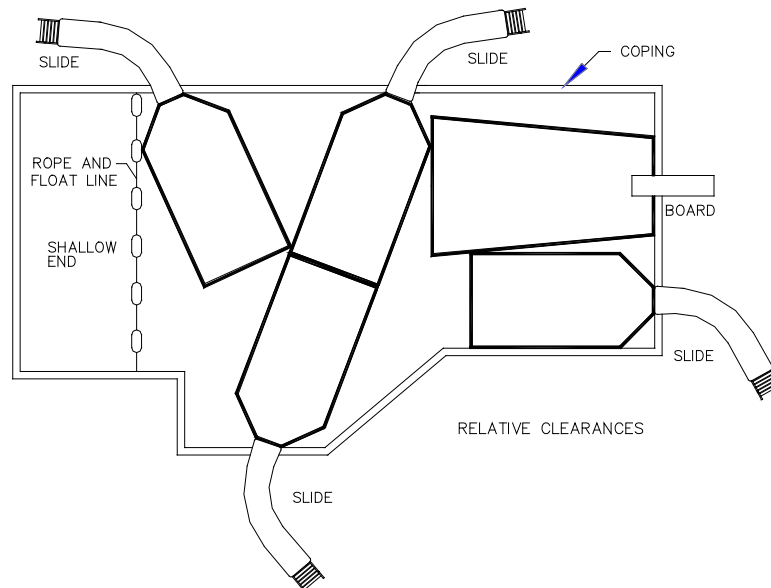

FIGURE OO