

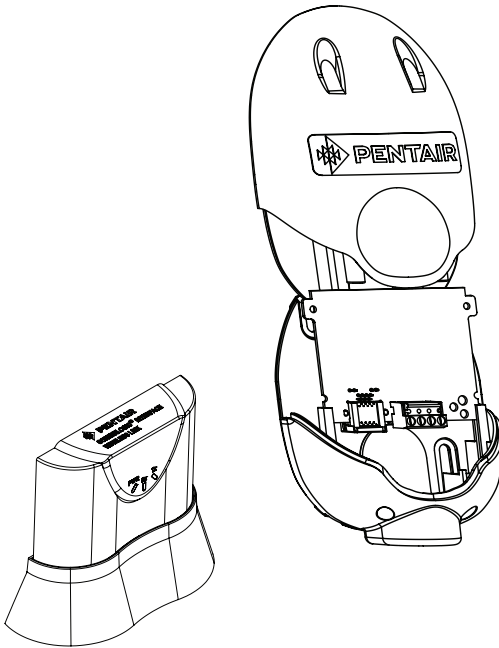

# HIGH POWER WIRELESS LINK KIT FOR INTELLICENTER™, INTELLITOUCH® AND EASYTOUCH® CONTROL SYSTEMS



## INSTALLATION GUIDE

IMPORTANT SAFETY INSTRUCTIONS  
READ AND FOLLOW ALL INSTRUCTIONS  
SAVE THESE INSTRUCTIONS

## Technical Support

Phone: (800) 831-7133 - [www.pentair.com](http://www.pentair.com)

### Contents

FCC Regulatory Safety Notice.....	3
High Power Wireless Link Kit Overview .....	4
High Power Wireless Link Kit Contents.....	4
High Power Wireless Link Indoor Transceiver LEDs and Connectors .....	5
<b>High Power Wireless Link For ScreenLogic Interface Systems .....</b>	<b>6</b>
Mounting Indoor Transceiver .....	6
Mounting Outdoor Transceiver .....	8
Connect Transceiver Cable to the RS-485 COM Port.....	8
<b>IntelliCenter Control System</b> <b>(Replacing Existing Wireless Antenna with HPW Link) .....</b>	<b>13-14</b>
<b>IntelliCenter Control System</b> <b>(Without an Existing Transceiver) .....</b>	<b>15</b>



#### FCC Regulatory Safety Notice

##### FCC non-modification statement:

Changes or modifications not expressly approved by the party responsible for compliance could void the user's authority to operate the equipment.

##### FCC RF Exposure requirements:

##### Notice for High Power Wireless Link (FCC ID: 2AHWAQTSHPWETH -

**HVIN/MODEL: HPW-WETHLINK:** In order to comply with FCC/ISED RF Exposure requirements, a minimum separation distance of 8 in (20 cm) must be maintained between the equipment and all persons during normal operation.

##### Exigences de la FCC en matière d'exposition aux fréquences radio:

##### Remarque: pour lien sans fil haute puissance (FCC ID: 2AHWAQTSHPWETH -

**HVIN/MODEL: HPW-WETHLINK:** Afin de respecter les exigences d'exposition RF de la FCC / ISED, une distance minimale de 20 cm doit être respectée entre l'appareil et toutes les personnes en fonctionnement normal.

##### Canada - Innovation, Science and Economic Development (ISED)

**(ISED: 21176-QTSHPWETH):** The Control System and the High Power Wireless (HPW) Link complies with RSS210 of ISED Canada (2019). Operation is subject to the following two conditions: (1) this device may not cause interference, and (2) this device must accept any interference, including interference that may cause undesired operation of the device.

This Class B digital apparatus complies with Innovation, Science and Economic Development (ISED) Exempt RSSs. Operation is subject to the following: (1) This device may not cause interference; and (2) This device must accept interference that may cause undesired operation of the device.

*Continue on next page.*



## FCC Regulatory Safety Notice (Continued)

Le dispositif est conforme à la licence Innovation, Science and Economic Development (ISED) Canada. Le fonctionnement est soumis à la suivante. (1) Ce ne doit pas provoquer d'interférences ; et (2) Cet appareil doit accepter les interférences qui peuvent causer un mauvais fonctionnement de l'appareil.

Cet appareil numérique de classe B est conforme à la norme canadienne ISDE (RSP-100, section 2.1) et Terminal Equipment Registrations (DC-01, Section 3.). Cet appareil numérique de la classe B est conforme à la norme NMB-003 du Canada. Le terme «ISED» précédant le numéro de certification / d'enregistrement signifie uniquement que les spécifications techniques relatives à l'innovation, à la science et au développement économique ont été respectées.

### FCC Regulatory Notice - 47 CFR Part 15, Subpart C

**Instruction to User:** This equipment has been tested and found to comply with the limits for a Class B digital device, pursuant to Part 15 of the FCC Rules. These limits are designed to provide reasonable protection against harmful interference in a residential installation. This equipment generates, uses and can radiate radio frequency energy and, if not installed and used in accordance with the instructions, may cause harmful interference to radio communications. However, there is no guarantee that interference will not occur in a particular installation. If this device does cause harmful interference to radio or television reception, which can be determined by switching the device off and on, the user is encouraged to try to correct the interference by one or more of the following measures:

- Reorient or relocate the receiving antenna.
- Increase the separation between the equipment and receiver.
- Connect the equipment into an outlet on a circuit different from that to which the receiver is connected.
- Consult the dealer or an experienced radio/TV technician for help.

### Industry Canada (IC) Regulatory Notice – RSS210:

**Instruction To User:** This device complies with RSS210 of Innovation, Science and Economic Development Canada (ISED). Under ISED regulations, this radio transmitter may only operate using an antenna of a type and maximum (or lesser) gain approved for the transmitter by ISED. To reduce potential radio interference to other users, the antenna type and its gain should be so chosen that the equivalent isotropically radiated power (e.i.r.p.) is not more than that necessary for successful communication. This device complies with Innovation, Science and Economic Development Canada licence-exempt RSS standard(s). Operation is subject to the following two conditions: (1) this device may not cause interference, and (2) this device must accept any interference, including interference that may cause undesired operation of the device.

Conformément à la réglementation d'Innovation, Sciences et Développement Économique Canada (ISED), le présent émetteur radio peut fonctionner avec une antenne d'un type et d'un gain maximal (ou inférieur) approuvé pour l'émetteur par ISED. Dans le but de réduire les risques de brouillage radioélectrique à l'intention des autres utilisateurs, il faut choisir le type d'antenne et son gain de sorte que la puissance isotrope rayonnée équivalente (p.i.r.e.) ne dépasse pas l'intensité nécessaire à l'établissement d'une communication satisfaisante. Le présent appareil est conforme aux CNR d'Innovation, Sciences et Développement Économique Canada applicables aux appareils radio exempts de licence. L'exploitation est autorisée aux deux conditions suivantes : (1) l'appareil ne doit pas produire de brouillage, et (2) l'utilisateur de l'appareil doit accepter tout brouillage radioélectrique subi, même si le brouillage est susceptible d'en compromettre le fonctionnement.

## High Power Wireless Link Kit Overview

The High Power Wireless Link consists of an indoor and outdoor 902-928 MHz wireless transceiver. Note: The wireless transceivers ship from the factory as a matched pair. The ID numbers on each transceiver must be the same number to function correctly. If needed, the transceivers must be replaced as a matched pair. For more information, call Customer Support 800.831.7133.

**Automation Control System:** The High Power Wireless Link indoor and outdoor transceiver provide a wireless connection between the Internet and the IntelliCenter®, IntelliTouch® or EasyTouch® Control System Load Center (or Power Center) located at the equipment pad which eliminates hard wire connection from inside your home to the equipment pad.

## Installation Guide

This Installation Guide provides installation instructions for the High Power Wireless Link kit. For information about ScreenLogic Interface operation, refer to the ScreenLogic Interface User's Guide (P/N 520493).

## High Power Wireless Link Kit Contents

The following items show are included in the kit:

Note: ScreenLogic Interface Protocol Adapter and Cable (purchased separately)

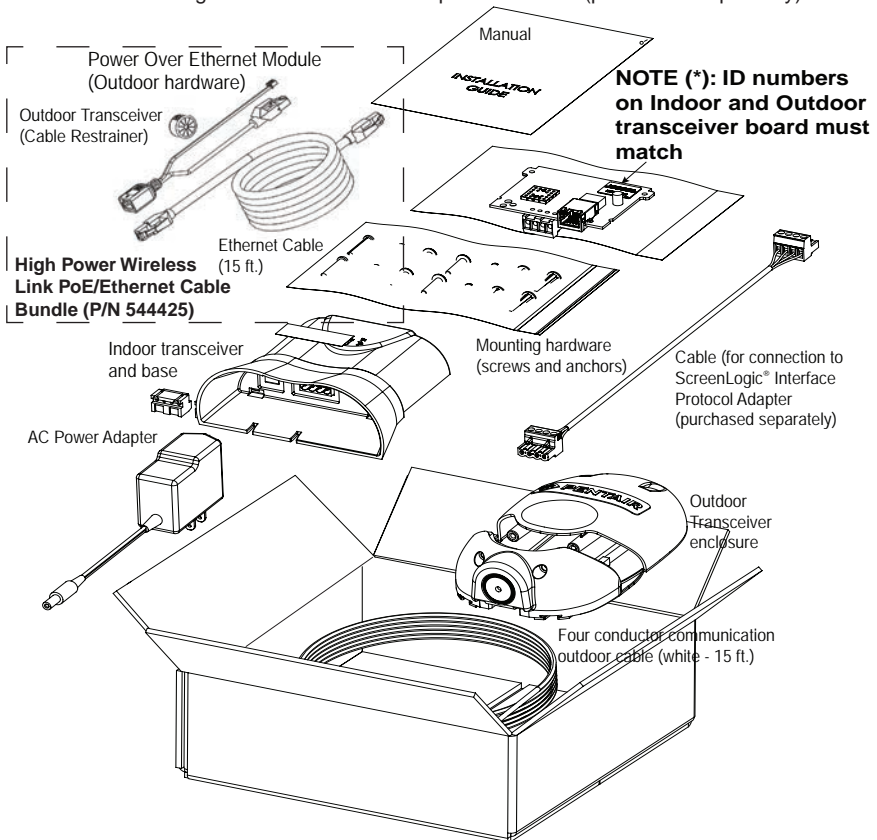

High Power Wireless Link Kit

# High Power Wireless Link Indoor Transceiver LEDs and Connectors

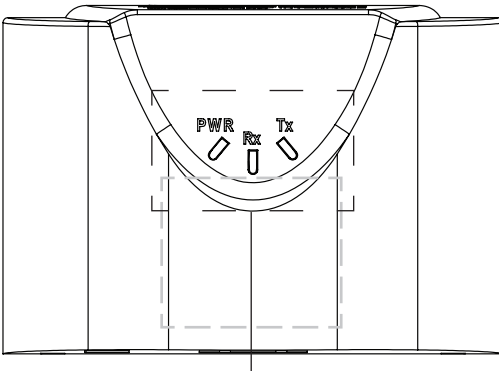

High Power Wireless Indoor Transceiver LEDs

**PWR:** Green LED on: Power is on to the unit.

**RX:** Yellow LED indicates the unit is receiving data.

**TX:** Green LED indicates the unit is transmitting data.

**PENTAIR**  
HIGH POWER WIRELESS LINK



**Keep this side clear of ALL metal objects for 2 ft. (61 cm)**

<b>Model:</b>	HPW-WETHLINK
<b>HVIN:</b>	HPW-WETHLINK
<b>FCC ID:</b>	2AHWAQTSHPWETH
<b>ISED:</b>	21176-QTSHPWETH

This device complies with Part 15 of the FCC rules. Operation is subject to the following two conditions: (1) this device may not cause interference, and (2) this device must accept any interference received, including interference that may cause undesired operation.

**Power Input**  
12 VDC - 500 mA

RS-485  
 RED  
 YELLOW  
 GREEN  
 BLACK

P/N 523446.A

RS-485 Connector (to Protocol Adapter, ScreenLogic only)

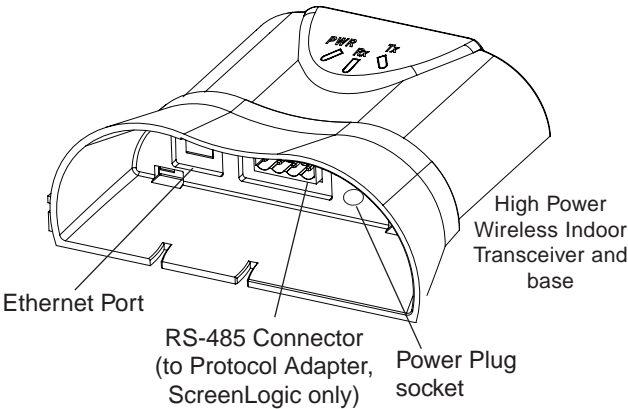

**IMPORTANT NOTICE:** Be sure the yellow ID label (8-digit ID number XXXXXXXX) located on the front side of the Indoor transceiver and the ID number on the outdoor transceiver circuit board are the same.

ID number (Outdoor transceiver)

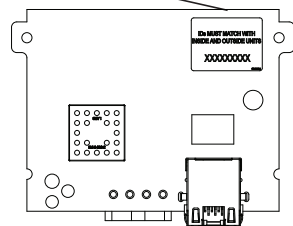

## High Power Wireless Link For ScreenLogic® Interface Systems

Connect the High Power Wireless (HPW) Indoor Transceiver to the ScreenLogic Interface Protocol Adapter as follow: See Figure 6 on page 12.

1. Using the provided 1 ft. RS-485 cable, connect one end of the cable plug to the Protocol adapter and the other end to the HPW Link indoor transceiver. The cable plugs are keyed for easy connection. See diagram below.
2. Plug the 120 VAC Power Adapter into an AC grounded electrical outlet. Plug the other end into the power socket on the HPW Link indoor transceiver.

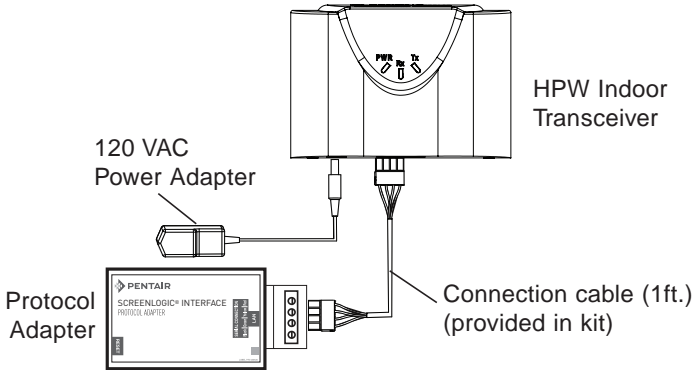

Connecting the HPW Indoor Transceiver and Protocol Adapter

### Base/Desk Mount the HPW Indoor Transceiver (Figure 1 on page 7)

Mount the HPW Indoor Transceiver in its base as follows:

1. Insert the power cable into the base of the HPW Link Indoor transceiver base. Fasten the cable into the cradle slot.
2. Insert the connection cable into the base of the transceiver cradle. Fasten the cable into the cradle slot.
3. Place the transceiver and base on a table or desk. Note: Keep the transceiver clear of all objects for two feet. **Note: Do not place the transceiver on the floor or behind a desk.**

**Wall Mount the HPW Indoor Transceiver (Figure 2 and Figure 3 on page 7).** Mount the HPW Indoor Transceiver on an indoor wall as follows:

1. Cut out the wall mounting template from the next page. Place the template on an indoor flat surface or wall and mark the two screw hole positions.
2. Drill two holes (0.223 in) 2-1/2 inches apart as shown on the template (see Figure 3 on next page).
3. Insert the wall plugs into both wall screw holes.
4. Insert the screws into the wall plug. Don't insert the screws all the way into the wall, leave about 1/16 in for the wireless transceiver to hang on the head of the screws (see Figure 2 on next page).
5. Mount the wireless transceiver onto both screw heads.

## Wall Mount the HPW Indoor Transceiver (Continued)

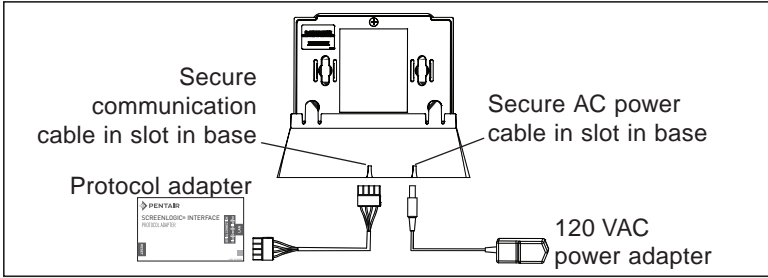

Figure 1: Cradle/Desk Mount the HPW Indoor Transceiver

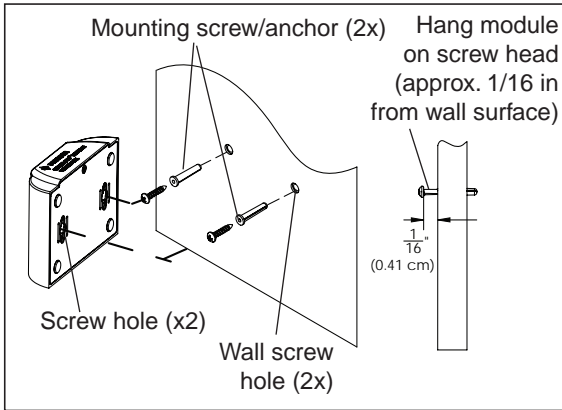

Figure 2: Wall Mount the Indoor Wireless Transceiver

### HPW Link Indoor Transceiver Mounting Screws Location

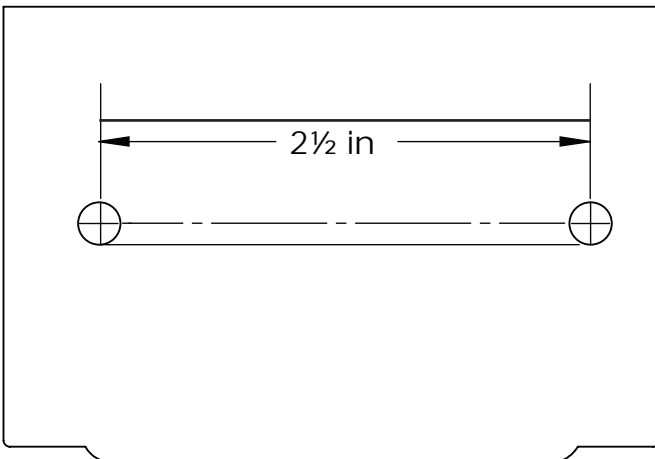

Figure 3: Wall Mount Template for HPW Link Indoor Transceiver

## Mounting and Connecting the Outdoor High Power Wireless (HPW) Link Transceiver to the Automation Control System Load Center

The following describes how to mount and connect the HPW Link outdoor transceiver to an IntelliTouch® or EasyTouch® Automation Control System Load Center or Power Center. See Figure 6 on page 12. The HPW Link outdoor transceiver is a two-way radio device with an attached antenna that communicates with the automation control system via a 15 ft. four-conductor RS-485 communication cable.

**HPW Outdoor Transceiver mounting location:** Choose a convenient location on a flat vertical surface near the Load Center at a minimum of 5 ft above ground level to optimize the transmit and receive operating range. For optimum performance position the HPW Link Outdoor transceiver with an unobstructed line-of-sight propagation between the HPW Indoor and Outdoor transceiver.

### Mounting the HPW Link Outdoor Transceiver

Mount the HPW Link outdoor transceiver as follows:

1. Remove the two screws securing the transceiver case. Slide the back plate downward out from the case.
2. *Note: To avoid signal interference, mount the transceiver a minimum of 10 feet away from the load center, any metal surface/structure, or air blower located in the immediate area of the equipment pad.* Position the back plate against the mounting surface so that the transceiver is oriented upright. Use a pencil to mark the four mounting points. Drill four 3/16 in. diameter holes into the mounting surface and insert the four plastic anchors provided in the kit.
3. Position the back plate over the mounting points and secure it to the surface with the four mounting screws provided in the kit.
4. Carefully position the transceiver circuit board into the mounted back plate. Route the communication cable wire up through the lower exit hole at the bottom of the back plate. Pull the communication cable through the lower hole and position the circuit board in the back plate.
5. Proceed to **Connect the HPW Outdoor Communication Cable to the RS-485 COM Port on Automation Control System** on the next page.
6. After wiring is complete, slide the case over the circuit board into the back plate. Secure the circuit board in the case using the two retaining screws.



## Connect the HPW Link Outdoor Transceiver Cable to the RS-485 COM Port on Automation Control System

**⚠ WARNING** Switch OFF the main power to the Load Center before making any connections.

1. Switch OFF the AC power to the enclosure at the main house panel circuit breaker.
2. Connect the four conductor connection cable to the screw terminal on the HPW Link Outdoor Transceiver circuit board as shown below in Figure 4.

Continue to next page.

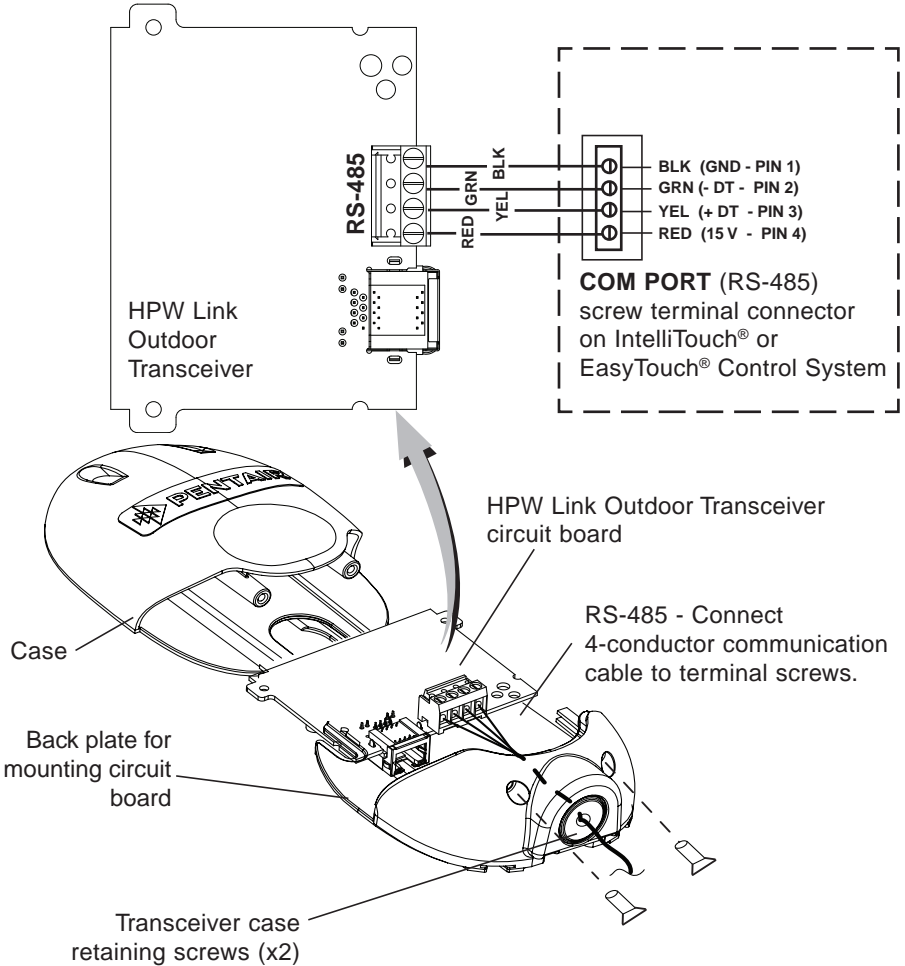

Figure 4. HPW Link Outdoor Transceiver

## Connect the HPW Outdoor Transceiver Cable to the RS-485 COM Port on Automation Control System (Continued)



**WARNING** Switch OFF the main power to the Load Center before making any connections.

3. Unlatch the front door latch and open the front door. Remove the two retaining screws from the High-Voltage Cover Panel and remove the panel. See Figure 5 below.
4. Loosen the two retaining screws securing from the top edge of the Outdoor Control Panel. Fold down the Outdoor Control Panel to access the circuit board sockets connectors for the electrical connections. Remove the panel from the enclosure.
5. Route the four conductor transceiver connection cable into the lower plastic grommet, up through the low voltage raceway to the system circuit board.

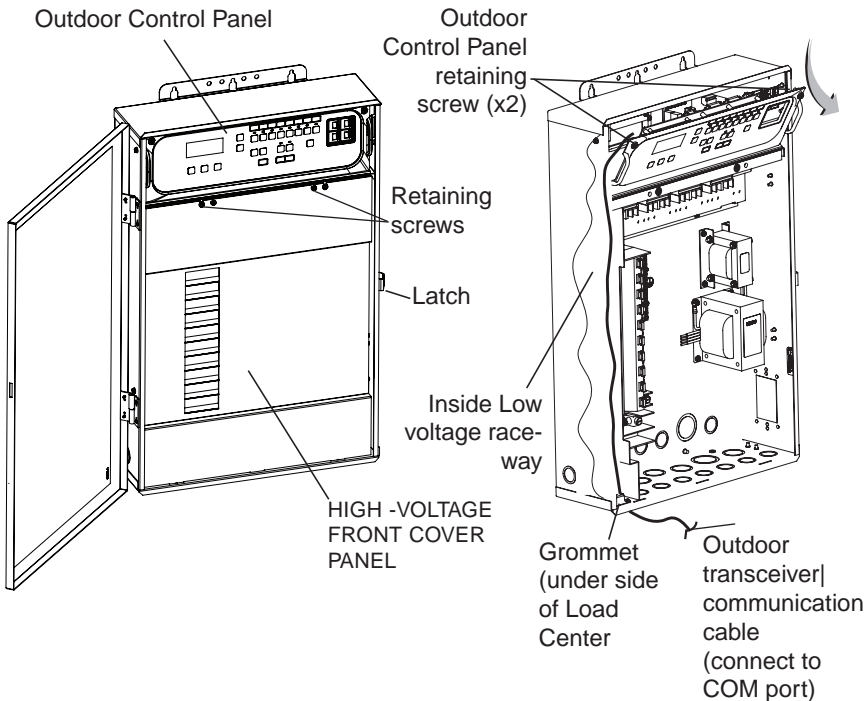
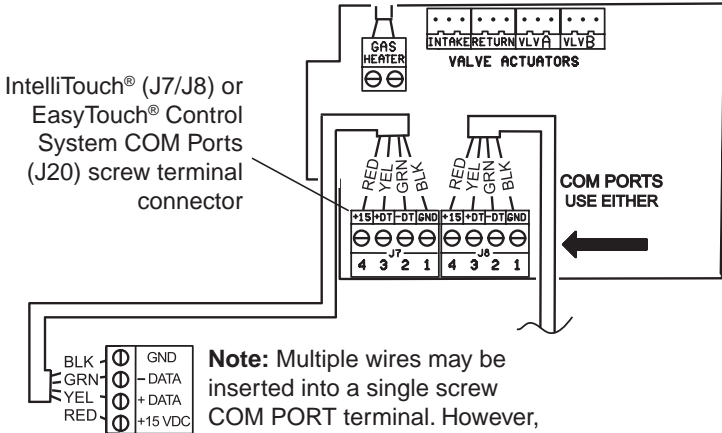

Figure 5. IntelliTouch® or EasyTouch® Control System Load Center

6. Strip the leads of the communication cable wires back  $\frac{1}{4}$  in. Insert the wires into the connector screw terminals. Using a small flat-blade screwdriver, secure the wires with the COM PORT (J7/J8) terminal screws. Note: Multiple wires may be inserted into a single screw terminal. Be sure to match the color-coding of the wires:

Pin 4 - Red = +15 VDC
Pin 3 - Yellow = +DT
Pin 2 - Green = -DT
Pin 1 - Black = GND



**Note:** Multiple wires may be inserted into a single screw COM PORT terminal. However, this can cause an intermittent connection. Note: For additional COM ports, an optional Serial COM Port Expansion Board (P/N 520818) can be installed in the low voltage compartment.

7. After the communication cable connection has been completed; close the Outdoor Control Panel and tighten the two retaining screws. Reinstall the High Voltage Panel: Insert the panel's three tabs into the lower slots on the enclosure. Secure the panel with the two (2) retaining screws. Close the front door and secure it with the latch.
8. Switch ON AC power to the Load Center.
9. After the Power Center is powered up the HPW Link outdoor transceiver will automatically synchronize with the system and will be ready for operation. **Note: The initial connection can take up to 2-3 minutes.**

Figure 6. High Power Wireless Link to EasyTouch or IntelliTouch Control System Connection Diagram

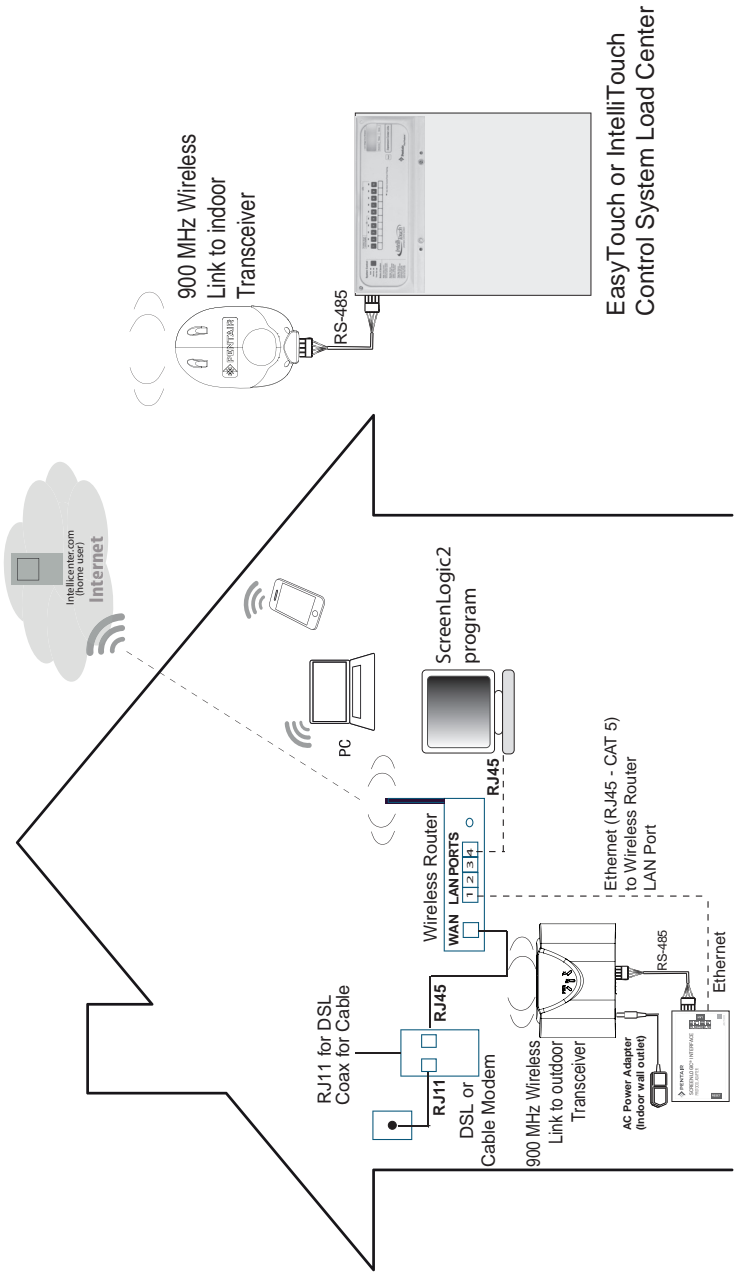

EasyTouch or IntelliTouch Control System Load Center

# INTELLICENTER® CONTROL SYSTEM (Replacing Existing Wireless Antenna with High Power Wireless (HPW) Link)



**WARNING** Switch OFF the main power to the Load Center before making any connections.

1. Switch OFF the AC power to the enclosure at the main house panel circuit breaker.
2. Unlatch the front door latch and open the front door. Remove the two retaining screws from the High-Voltage Cover Panel and remove the panel. See Figure 5 on page 10.
3. Loosen the two retaining screws securing from the top edge of the Outdoor Control Panel. Fold down the Outdoor Control Panel to access the circuit board connectors. See Figure 5 on page 10.
4. **Disconnect the Ethernet cable from the existing transceiver, and remove the transceiver:** To access the transceiver Ethernet port, remove the rear bottom panel from the antenna assembly. From the front of the antenna assembly, press down on the rear bottom panel clip to release it from the antenna assembly. See Figure 7 on page 14.
5. Remove the two screws securing the existing transceiver and remove the transceiver from its mounting position.
6. **Connect the HPW Link Outdoor Transceiver:** Connect the Ethernet cable (from the IntelliCenter Control System Power Module) to the Ethernet port on the HPW Link outdoor transceiver circuit board.
7. Mount and secure the HPW Link outdoor transceiver in the same location as the existing transceiver. Secure the transceiver in place with the two screws.
8. Slide case up over the circuit board and antenna into the back plate. Secure the circuit board in the case using the two retaining screws.
9. **Home Wireless Router Location: Connect Ethernet Cable (cat5) to Indoor HPW Link Transceiver and to Home Wireless Router (See Figure 7 on page 14):** Connect the Ethernet cable (provided) to a port on the home wireless router. Connect the other end of the Ethernet cable to the HPW Link indoor transceiver.
10. **Indoor Power Module Connection:** Connect the AC Power Adapter plug into the Power Module DC-IN socket and the plug other end into a AC wall outlet.

## System Start-Up

Refer to the IntelliCenter Control System using the step-by-step Setup Wizard. For more information refer to the IntelliCenter® Control System User's Guide (P/N 522990).

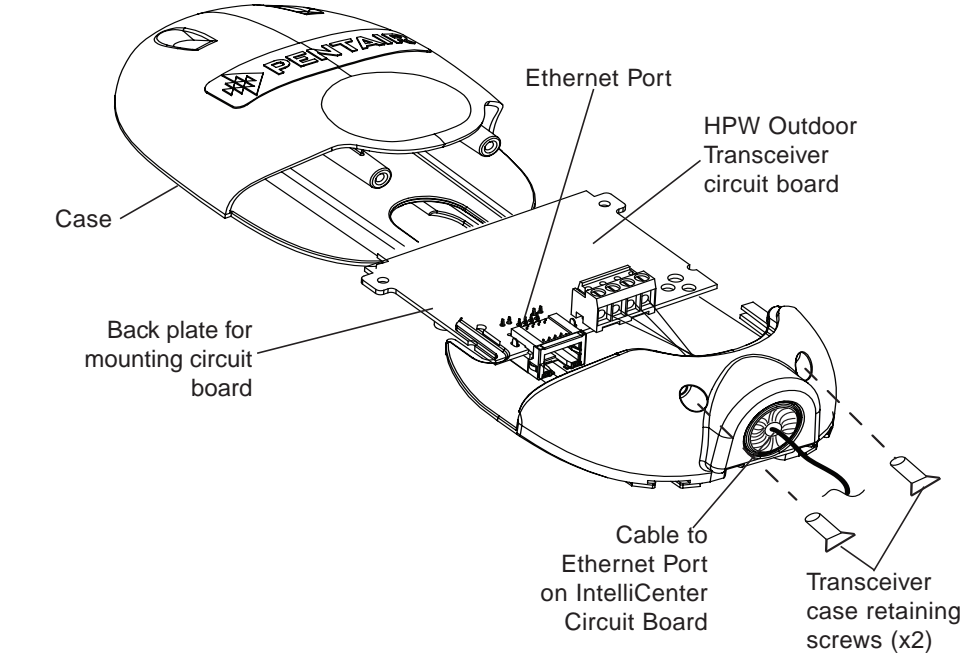

### HPW Link Outdoor Transceiver

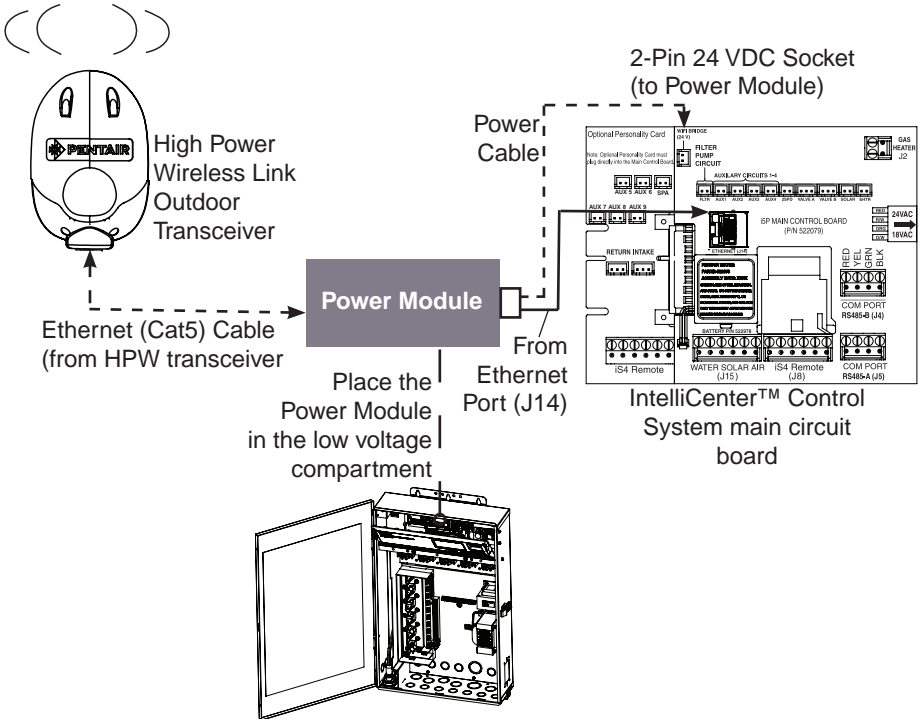

Figure 8. Power Module Connection

# INTELLICENTER CONTROL SYSTEM (Without an Existing Transceiver)



**WARNING** Switch OFF the main power to the Load Center before making any connections.

1. Switch OFF the AC power to the enclosure at the main house panel circuit breaker.
2. Unlatch the front door latch and open the front door. Remove the two retaining screws from the High-Voltage Cover Panel and remove the panel. See page 11 for connection diagram.
3. Loosen the two retaining screws securing from the top edge of the Outdoor Control Panel. Fold down the Outdoor Control Panel to access the circuit board connectors. See Figure 5 on page 10.
4. **Power Module Ethernet Cable Connection:** Connect the short Ethernet 1 ft cable (provided in kit) into the Ethernet port on the IntelliCenter Control System Outdoor Control Panel circuit board. Connect the other end into the LAN port on the Power Module. See Figure 7 on page 14.
5. Connect the Ethernet cable (15 ft cable provided in kit) into the LAN port on the Power Module. Route the cable down the Load Center raceway and out of the lower opening of the Load Center or Power Center.
6. **Power Module Power Connection:** Connect the 24VDC connector into the Power Module DC-IN socket and the plug other end into the IntelliCenter Control System Outdoor Control Panel circuit board. See Figure 7 on page 14.
7. Route the Ethernet cable (15 ft cable provided) to the HPW Link outdoor transceiver. Remove the knockout on the bottom of the transceiver and insert the Hole Plug into the opening. Route the cable through the opening in the plug.
8. **Mount the HPW Link Outdoor Transceiver:** Mount the HPW outdoor transceiver to a vertical flat surface near the Load Center. Secure the transceiver in place with the two screws.
9. Remove the two screws from the HPW Link antenna transceiver case. Slide the case down to access the Ethernet port on the circuit board.
10. Slide case up over the circuit board and antenna into the back plate. Secure the circuit board in the case using the two retaining screws.
11. **Home Wireless Router Location: Connect Ethernet Cable (cat5) to Indoor HPW Link Transceiver and to Home Wireless Router (See Figure 8 on page 14):** Connect the Ethernet cable (provided) to a port on the home wireless router. Connect the other end of the Ethernet cable to the HPW Link indoor transceiver.
12. **Power Module Connection:** Connect the AC Power Adapter plug into the Power Module DC-IN socket and the plug other end into a AC wall outlet.



1620 HAWKINS AVE., SANFORD, NC 27330 • (919) 566-8000  
10951 WEST LOS ANGELES AVE., MOORPARK, CA 93021 • (805) 553-5000

[WWW.PENTAIR.COM](http://WWW.PENTAIR.COM)

All indicated Pentair trademarks and logos are property of Pentair Inc. or its global affiliates in the U.S.A. and/or other countries. Third party registered and unregistered trademarks and logos are the property of their respective owners

© 2019 Pentair. All rights reserved.  
This document is subject to change without notice.

