

Assembly Instructions One Meter Sportflyte Diving Tower (With Flanged Pedestal)

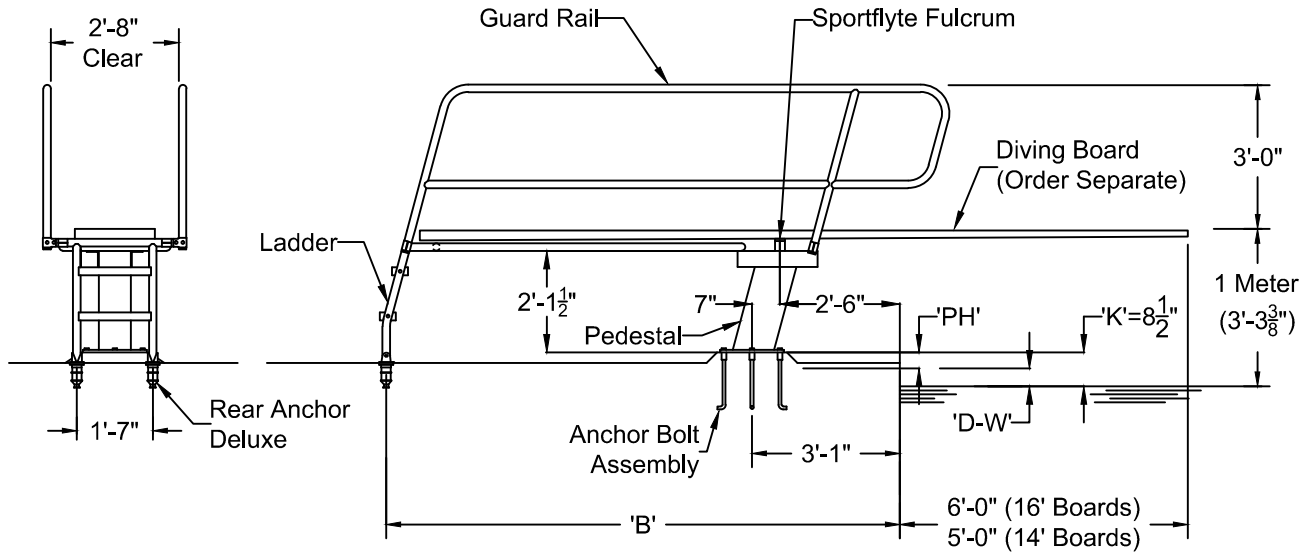

Dear Valued Customer,

Thank you for your recent purchase of our 1 Meter Sportflyte diving tower. The following instructions will assist you in the assembly of your tower. Page one of this document provides a side and rear view of how your tower will look when assembled and also gives anchor locations. Page two is an isometric 3-dimensional drawing which will aid in parts identification as well as parts locations. Page three provides step by step written instructions on how to assemble the tower. We trust that you will enjoy much satisfaction with the equipment you have purchased, and thank you for choosing Paragon deck equipment!

'K' DIMENSION	DECK TO WATER ('D-W')	PAD HEIGHT ('PH')
8 1/2"	0"	8 1/2"
8 1/2"	1"	7 1/2"
8 1/2"	2"	6 1/2"
8 1/2"	3"	5 1/2"
8 1/2"	4"	4 1/2"
8 1/2"	5"	3 1/2"
8 1/2"	6"	2 1/2"
8 1/2"	7"	1 1/2"
8 1/2"	8"	1/2"

Notes:
'K' Dimension = Top of pad to water line ('PH' + 'D-W')

BOARD TYPE	'B' DIMENSION
16' CENTURY	10'-8 1/2"
16' PARAFLEX	10'-8 1/2"
14' CENTURY	9'-8 1/2"
14' PARAFLEX	9'-8 1/2"

Notes:
'B' Dimension = Pool wall to center line of rear anchor deluxe

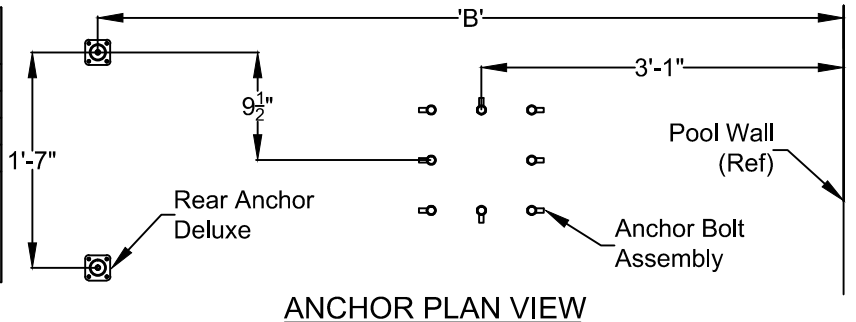

Supersedes Assembly Instructions Dated 5/20/11



PARAGON AQUATICS
Pentair Water
Commercial Pool & Aquatics

1351 Route 55
LaGrangeville, New York
12540
Phone: 845-463-7200
Fax: 845-463-7291
www.paragonaquatics.com

Dwn by: Date:
SF 2/22/13
App by: Date:
JMM 2/22/13

Title:
**1 Meter Sportflyte Diving Tower,
Flanged Pedestal Assembly Drawing**
Drawing Number:
AI-DT10.29

Material:
See Notes/Schedule
Tolerance:
(Unless noted)
N/A
Scale:
N/A
Rev Ltr:
D
Sheet:
1 of 3

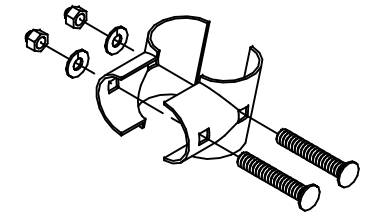

Split Tee Assembly

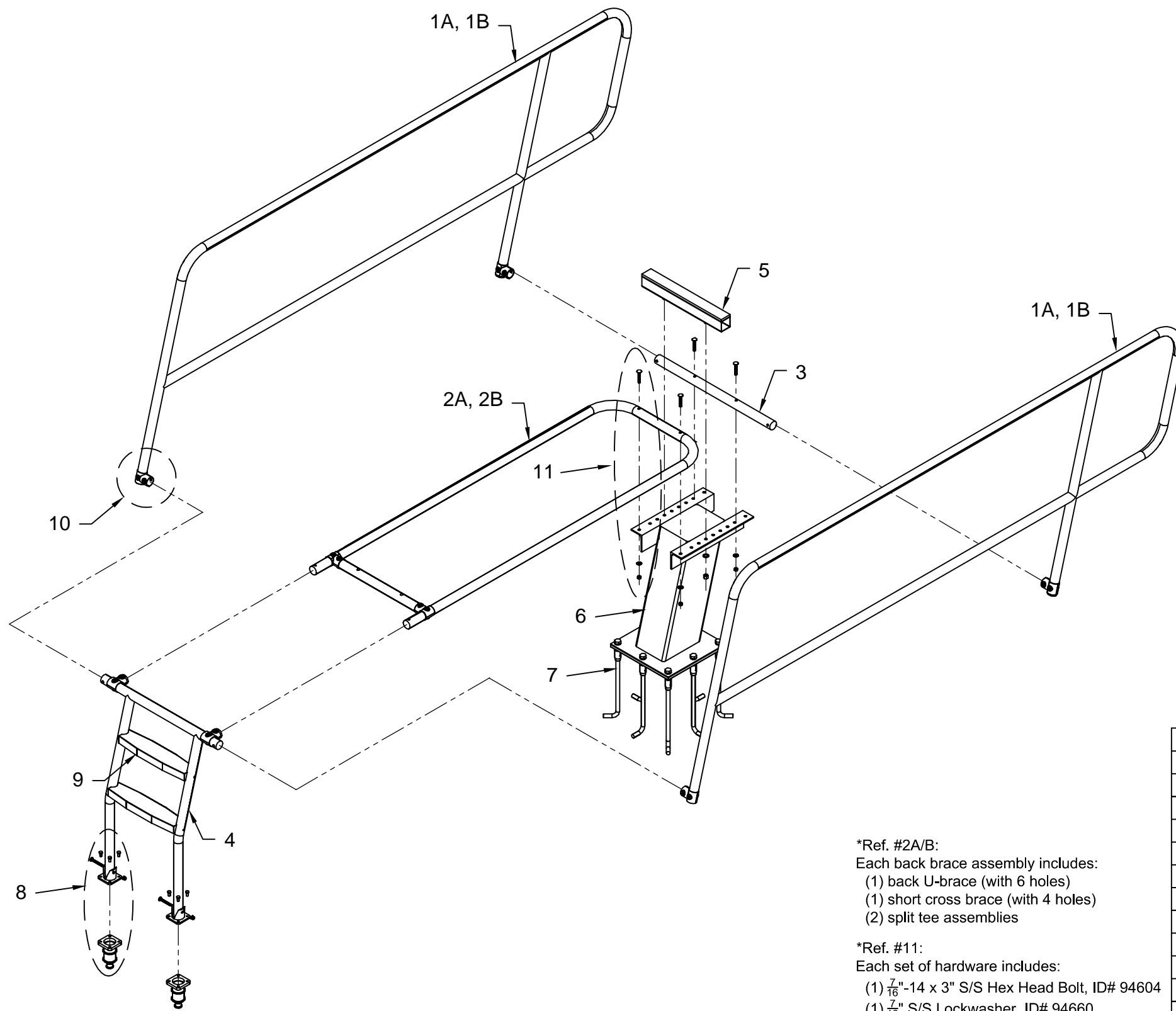

(Verify Board Type and/or Length when ordering REF #1 and 2)

REF #	DESCRIPTION	QTY	PART #
1A	Guard Rail Side Frame (16' Board)	2	13079
1B	Guard Rail Side Frame (14' Board)	2	13080
2A*	Back Brace Assembly (16' Board)	1	13074
2B*	Back Brace Assembly (14' Board)	1	13075
3	Front Brace	1	13078
4	Ladder Risers with Top Cross Bar	1	13077
5	Sportflyte Fulcrum	1	13554
6	Pedestal	1	13562
7	Pedestal Anchor	1	12307
8	Rear Anchor Deluxe (with hardware)	2	28201
9	19" ABS Sloping Step (with hardware)	2	44104
10	Split Tee Assembly (with hardware)	8	12501
11	Superstructure to Pedestal Mounting Hardware	4 sets	*

*Ref. #2A/B:
Each back brace assembly includes:
(1) back U-brace (with 6 holes)
(1) short cross brace (with 4 holes)
(2) split tee assemblies

*Ref. #11:
Each set of hardware includes:
(1) 7/16"-14 x 3" S/S Hex Head Bolt, ID# 94604
(1) 7/16" S/S Lockwasher, ID# 94660
(1) 7/16"-14 S/S Hex Nut, ID# 94650

This data represents the latest knowledge available to us at time of presentation. However Paragon Aquatics and others involved in gathering and presenting this drawing assume no liability for its use.

© 2013 Paragon Aquatics

Supersedes Assembly Instructions Dated 5/20/11



**PARAGON
AQUATICS**

Pentair Water
Commercial Pool & Aquatics

1351 Route 55
LaGrangeville, New York
12540
Phone: 845-463-7200
Fax: 845-463-7291
www.paragonaquatics.com

Dwn by: Date:
SF 2/22/13

App by: Date:
JMM 2/22/13

Title:
1 Meter Sportflyte Diving Tower, Flanged
Pedestal Assembly Drawing

Drawing Number:
AI-DT10.29

Material:
See Notes/Schedule

Tolerance:
(Unless noted)
N/A

Scale: Rev Ltr: Sheet:
N/A D 2 of 3

1 METER SPORTFLYTE DIVING TOWER ASSEMBLY INSTRUCTIONS:

General Notes: Your 1 Meter Sportflyte diving tower has been shipped with some parts (side frames, rear frame) pre-assembled at our factory. Prior to beginning, please inspect all pieces and boxes to ensure that parts were not damaged in transit. If damage is detected, notify your distributor/freight carrier immediately as a freight claim **must** be filed within a certain time frame from receipt of goods. Take a moment to review the front pages of this assembly drawing to familiarize yourself with the tower components and to verify all parts have been received.

Assembly Instructions:

1. Bolt the pedestal (ref. #6) to the pedestal anchor (ref. #7) with the (8) 3/4" x 2" hex head bolts and 3/4" lockwashers. Check pedestal cap for level and alignment, and tighten bolts securely. - *Note: Assembly and erection of the tower should be done in sequence and all bolted connections should be hand tight until directed otherwise.*
2. The ladder risers (ref. #4) usually have to be trimmed so that the side frames will be level after erection. Take a vertical measurement from the top of the pedestal to the top of the body of each rear anchor (ref. #9). Deduct the measured amount from 35". The difference is the amount to be trimmed from the bottom of each ladder riser. Trim accordingly.
3. Attach the steps (ref. #9) to the ladder risers using the 5/16" X 2 3/4" curved head bolts included. When tightening, do not over tighten as this may damage the plastic step.
4. To create back brace assembly (ref#2), attach short cross brace with (4) hole to the back U-brace via (2) split tee assemblies (ref #10).
5. Lay the completed ladder riser assembly on its side and attach the back brace assembly (ref. #2) via (2)split tee assemblies (ref. #10).
6. Slip the flange portion of the rear anchor over the bottom of each ladder riser. Leave loose for now. Raise the assembly upright and slip the legs into the rear sockets. The front end of the back brace will rest on the pedestal cap.
7. Attach the back brace assembly to the rear of the pedestal cap using (2) 7/16" X 3" hex head bolts, with the nuts on the underside of the pedestal cap (See superstructure to pedestal mounting hardware - ref#11).
8. The ladder risers must be drilled for attachment of the flanges. Attach the flange to the rear anchor body by using (4) 3/8" X 3/4" hex head bolts with lockwashers. Drill through the clamp flange holes and ladder risers using a 13/32" drill bit. Insert a 3/8" X 3" carriage bolt through the holes of the clamp flange and riser leg and secure with a cap nut. *Note: Drilling through stainless steel will require a slow speed drill, lubrication, and constant feed pressure.*
9. Attach the front brace (ref. #3) to the front end of the pedestal cap using (2) 7/16" X 3" hex head bolts with the nuts on the underside of the pedestal cap (See superstructure to pedestal mounting hardware - ref#11). - **Caution:** *This bar must be properly oriented so that it will receive the guard rail assembly.*
10. Attach each guard rail (ref. #1) to the front brace and to the ladder riser assembly via (4) split tee assemblies (ref#10).
11. Attach the fulcrum assembly (ref. #5) to the pedestal cap using (2) 3/8" X 1 1/4" hex head bolts. - *Note: Set the fulcrum to comply with the board manufacturer's fulcrum range.*
12. All connections, which were hand tight, should now be securely tightened by wrench.
13. Paint the primed pedestal.

Caution: *All bolts should be checked regularly and tightened when necessary.*

Supersedes Assembly Instructions Dated 5/20/11

 PARAGON AQUATICS Pentair Water Commercial Pool & Aquatics	1351 Route 55 LaGrangeville, New York 12540 Phone: 845-463-7200 Fax: 845-463-7291 www.paragonaquatics.com	Dwn by: Date: SF 2/22/13	Title: 1 Meter Sportflyte Diving Tower, Flanged Pedestal Assembly Drawing			Material: See Notes/Schedule	
		App by: Date: JMM 2/22/13	Drawing Number: AI-DT10.29	Tolerance: (Unless noted) N/A	Scale: N/A	Rev Ltr: D	Sheet: 3 of 3