

Welded Figure 4 Grab Rail

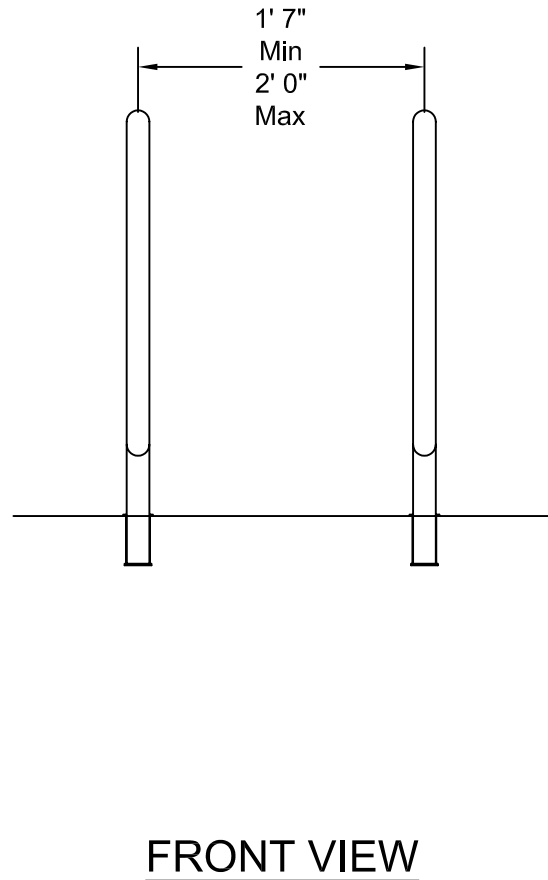
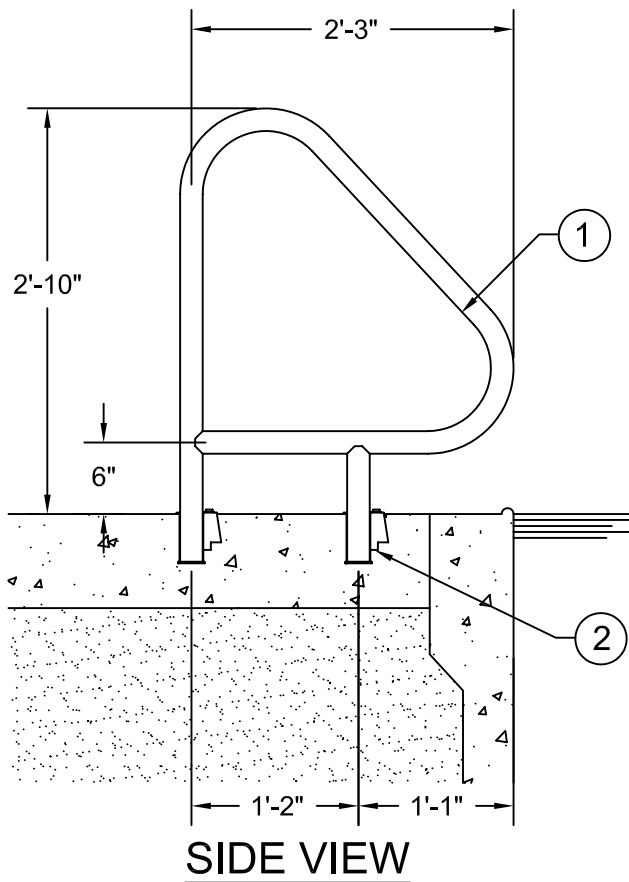

Part Number: 30511 (1.90" x .145" T304 s/s)
 30512 (1.90" x .109" T304 s/s)
 30513 (1.90" x .065" T304 s/s)

Specifications

- ① The grab rails shall be furnished as a pair. Each shall be fabricated from ASTM A-554 certified 1.90" x _____" wall thickness Type 304 stainless steel polished to a 320 grit finish. Joints shall be welded, cleaned and blended to match the finish of the pipe. All bends shall be smooth and free of wrinkles.
- ② The grab rails shall be anchored in 4" deep bronze wedge anchor sockets (not included), which shall be fully embedded in a concrete deck.

General

The stainless steel frame shall be electro-chemically passivated on all worked areas for maximum corrosion resistance. All hardware shall be 18-8 stainless steel. Custom designs and modifications are available upon request.

The data represents the latest knowledge available to us at time of presentation. However, Paragon Aquatics and others involved in gathering and presenting this drawing assume no liability for its use.

© 2008 Paragon Aquatics



**PARAGON
AQUATICS**
Pentair Water
Commercial Pool & Aquatics

1351 Route 55
LaGrangeville, New York
12540
Phone: 845-463-7200
Fax: 845-463-7291
www.paragonaquatics.com

Drawn by: JMM	Date: 6/27/08	Approved by: RV	Date: 6/27/08
Sheet Title: Welded Figure 4 Grab Rail			
Drawing Number: SS-GR20.46	Revision Letter: C	Sheet: 1 of 1	