

Assembly Instructions for Three Meter Duradapt Diving Tower (Ladder at Side with Flanged Pedestal)

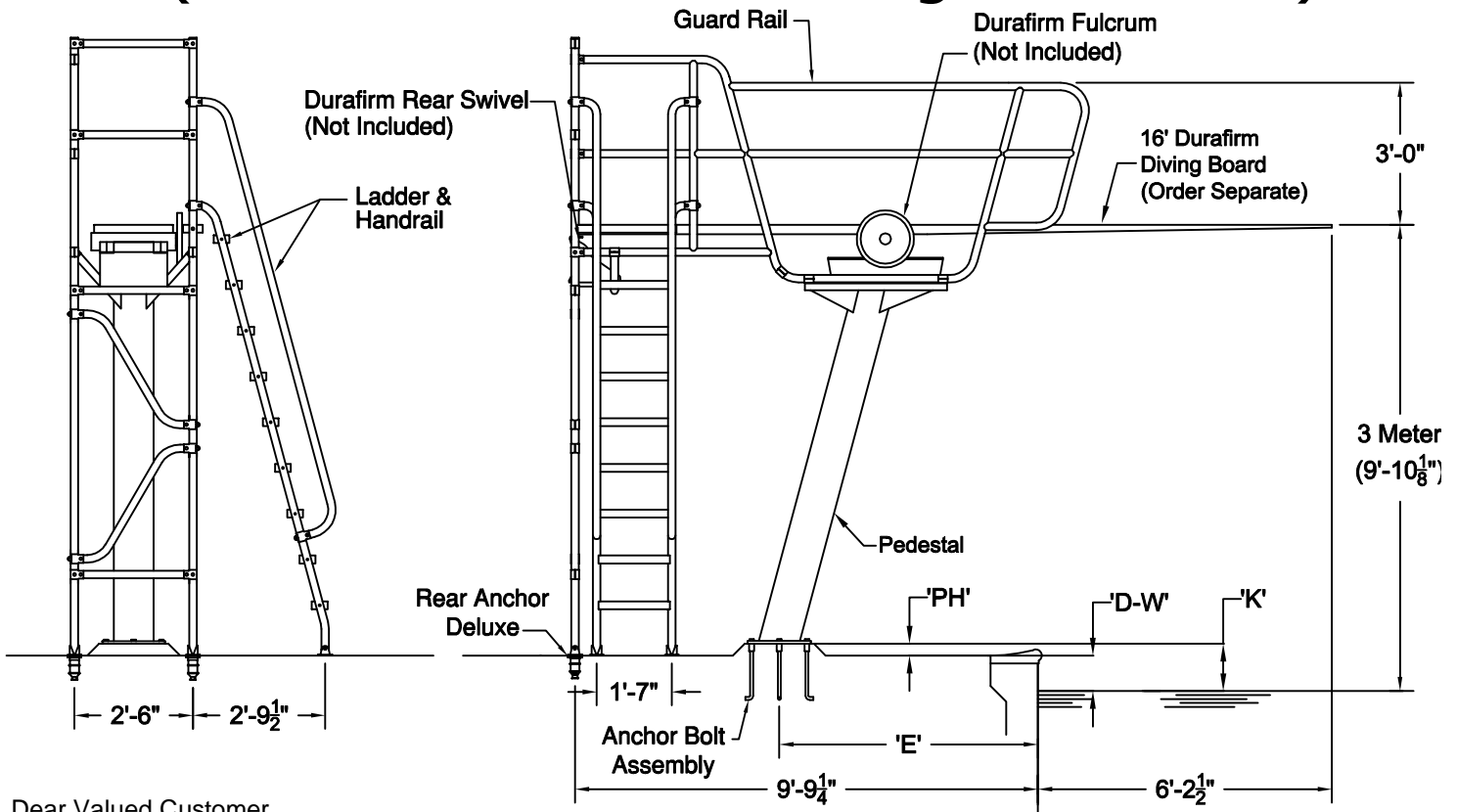

Dear Valued Customer,

Thank you for your recent purchase of our 3 Meter Duradapt diving tower with ladder at side. The following instructions will assist you in the assembly of your tower. Page one of this document provides a side and rear view of how your tower will look when assembled and also gives anchor locations. Page two is an isometric 3-dimensional drawing which will aid in parts identification as well as parts locations. Page three provides step by step written instructions on how to assemble the tower. We trust that you will enjoy much satisfaction with the equipment you have purchased, and thank you for choosing Paragon deck equipment!

'K' DIMENSION	DECK TO WATER ('D-W')	PAD HEIGHT ('PH')	PEDESTAL HEIGHT	'E' DIMENSION
6"	0"	6"	97 1/2"	67 1/8"
6"	1"	5"	97 1/2"	67 1/8"
6"	2"	4"	97 1/2"	67 1/8"
6"	3"	3"	97 1/2"	67 1/8"
6"	4"	2"	97 1/2"	67 1/8"
6"	5"	1"	97 1/2"	67 1/8"
6"	6"	0"	97 1/2"	67 1/8"
12"	7"	5"	91 1/2"	65 1/2"
12"	8"	4"	91 1/2"	65 1/2"
12"	9"	3"	91 1/2"	65 1/2"
12"	10"	2"	91 1/2"	65 1/2"
12"	11"	1"	91 1/2"	65 1/2"
12"	12"	0"	91 1/2"	65 1/2"
>12"	Custom - Call for Details			

Notes:

'K' Dimension = Top of pad to water line ('PH' + 'D-W')

'E' Dimension = Edge of pool wall to center line of bottom of pedestal

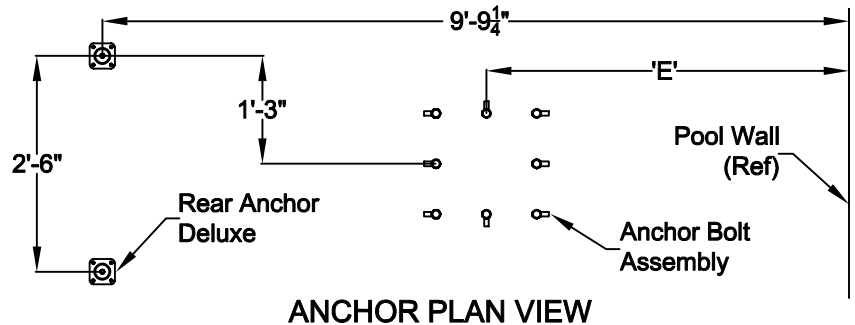

ANCHOR PLAN VIEW

Supersedes Assembly Instructions dated 1/27/11



PARAGON AQUATICS
 Pentair Water
 Commercial Pool & Aquatics

1351 Route 55
 LaGrangeville, New York
 12540
 Phone: 845-463-7200
 Fax: 845-463-7291
 www.paragonaquatics.com

Dwn by: SF	Date: 2/27/12	Title: 3 Meter Duradapt Diving Tower, Ladder At Side, Flanged Pedestal Assembly Drawing	Material: See Notes/Schedule
App by: RV	Date: 2/27/12	Drawing Number: AI-DT10.01S	Tolerance: (Unless noted) N/A
		Scale: N/A	Rev Ltr: F
			Sheet: 1 of 3

Note: Some tee assemblies (Ref. #'s 17 & 18) may be pre-assembled mechanically and/or welded to superstructure at factory.

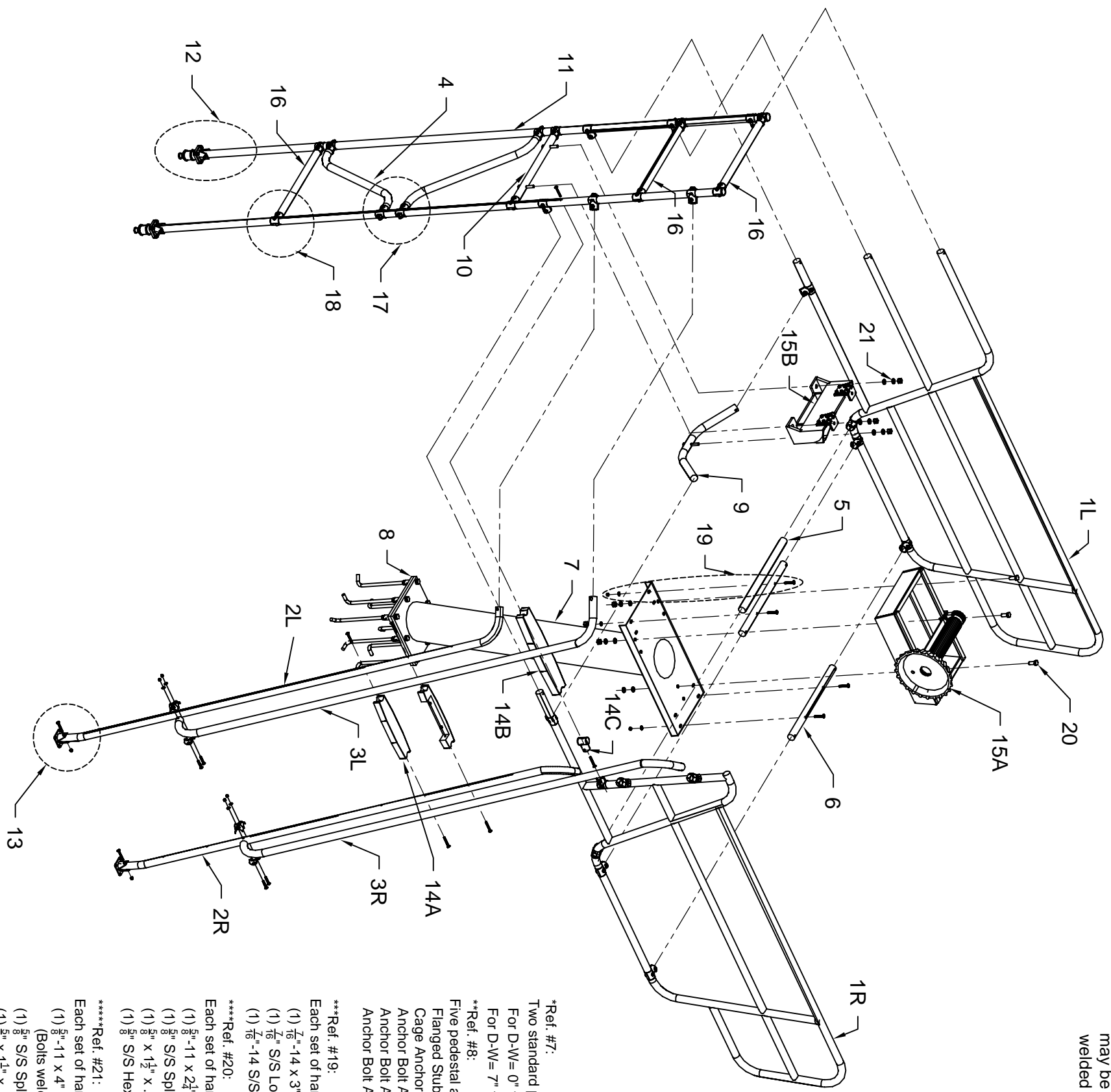
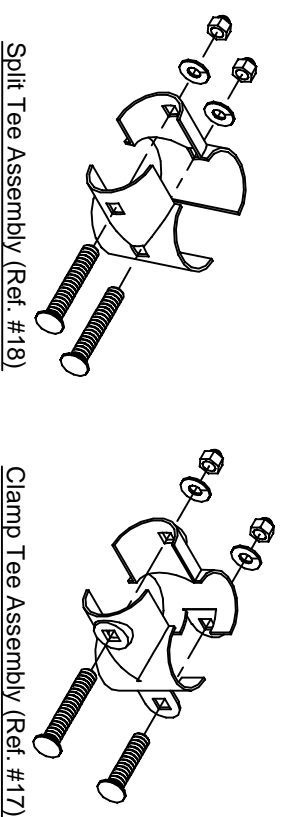

Certain parts contain Suffix X=U: Ultraflyte / Superflyte (select one)

REF #	DESCRIPTION	QTY	PART #
1L	Guard Rail Side Frame- Left hand side	1	13046LX
1R	Guard Rail Side Frame- Right hand side	1	13046RX
2L	Ladder Riser- Left hand side	1	13047LX
2R	Ladder Riser- Right hand side	1	13047RX
3L	Hand Rail- Left hand side	1	13045LX
3R	Hand Rail- Right hand side	1	13045RX
4	S' Brace	2	13049X
5	Rear Cross Tie	1	13040X
6	Pedestal Cross Bar	2	13042
7	Pedestal	1	*
8	Pedestal Anchor	1	**
9	Rear Swivel Front Support Bar	1	13035
10	Rear Swivel Back Support Bar	1	13036
11	Rear Leg	2	13044X
12	Rear Anchor Deluxe	2	28201
13	Clamp Flange Assembly	2	28202
14A	19" ABS Sloping Step (with hardware)	9	44104
14B	26" ABS Vertical Step (with hardware)	1	44107
14C	Step Adaptor	1	13303
14D	Step Adaptor	1	13303
15A	Durafirm Fulcrum (ordered separately)	1	24111A
15B	Durafirm Rear Swivel (ordered separately)	1	24111B
16	Rear Cross Tie	3	13040R
17	Clamp Tee Assembly (with hardware)	12	12503
18	Split Tee Assembly (with hardware)	19	12501
19	Superstructure to Pedestal mounting hardware	4 sets	****
20	Fulcrum to Pedestal mounting hardware	3 sets	****
21	Rear Swivel mounting hardware	3 sets	****

*Ref. #7:
Two standard pedestal heights are available:
For D-W= 0" to 6"- ID# 12314, 97 1/2" high pedestal
For D-W= 7" to 12"- ID# 12315, 91 1/2" high pedestal

**Ref. #8:
Five pedestal anchors are available:
Flanged Stub Assembly- ID# 12301
Cage Anchor Assembly- ID# 12304
Anchor Bolt Assembly- ID# 12307
Anchor Bolt Assembly (all S/S)- ID# 12308
Anchor Bolt Assembly (S/S bushings & HW w/ CS 'J' bolts)- ID# 12309

***Ref. #19:
Each set of hardware includes:
(1) 1/8"-14 x 3" S/S Hex Head Bolt, ID# 94604
(1) 1/8" S/S Lockwasher, ID# 94660
(1) 7/16"-14 S/S Hex Nut, ID# 94650

****Ref. #20:
Each set of hardware includes:
(1) 5/8"-11 x 2 1/4" S/S Hex Head Bolt, ID# 94788
(1) 5/8" S/S Split Lockwasher, ID# 94390
(1) 5/8" x 1 1/2" x .078 S/S Flat Washer, ID# 94795
(1) 5/8" S/S Hex Nut, ID# 94794

*****Ref. #21:
Each set of hardware includes:
(1) 5/8"-11 x 4" S/S Hex Head Bolt, ID# 94793
(Bolts welded to rear swivels at factory)
(1) 5/8" S/S Split Lockwasher, ID# 94390
(1) 5/8" x 1 1/2" x .078 S/S Flat Washer, ID# 94795
(1) 5/8" S/S Hex Nut, ID# 94794

This data represents the latest knowledge available to us at time of presentation. However Paragon Aquatics and others involved in gathering and presenting this drawing assume no liability for its use.
© 2013 Paragon Aquatics

PARAGON AQUATICS
Pentair Water
Commercial Pool & Aquatics

1351 Route 55
LaGrangeville, New York
12540
Phone: 845-463-7200
Fax: 845-463-7291
www.paragonaquatics.com

Dwn by:	Date:	Title:	Material:
SF	2/27/12	3 Meter Duradapt Diving Tower, Ladder At Side, Flanged Pedestal Assembly Drawing	See Notes/Schedule
App by:	Date:	Drawing Number:	Scale:
RV	2/27/12	AI-DT10.01S	N/A
		Tolerance: (Unless noted)	Rev Ltr:
		N/A	F
			Sheet:
			2 of 3

3 METER DURADAPT DIVING TOWER (LADDER @ SIDE) FLANGED PEDESTAL ASSEMBLY INSTRUCTIONS:

General Notes: Your 3 Meter Duradapt diving tower has been shipped with some parts (Side Frames) pre-assembled at our factory. Prior to beginning, please inspect all pieces and boxes to ensure that parts were not damaged in transit. If damage is detected, notify your distributor/freight carrier immediately as a freight claim **must** be filed within a certain time frame from receipt of goods. Take a moment to review the front pages of this assembly drawing to familiarize yourself with the tower components and to verify all parts have been received. You'll notice that certain pieces are unique and will be depicted as left or right hand side (as viewed facing the pool from behind the tower). By reviewing the data sheets and by insuring that the open end of the T-connectors are facing each other, you can identify the left and right sides.

Assembly Instructions:

1. Bolt the pedestal (ref. #7) to the pedestal anchor (ref. #8) with the (8) $\frac{3}{4}$ " x 2" hex head bolts and $\frac{3}{4}$ " lockwashers. Check pedestal cap for level and alignment, and tighten bolts securely.
2. Rear Legs (ref. #11) usually have to be trimmed before erecting. Take an accurate vertical measurement from the top of the pedestal to the top of the rear anchor deluxe body (ref. #12). Deduct that measured amount from 103 $\frac{1}{2}$ ". The difference is the amount to be trimmed from the bottom of each leg. Trim the legs accordingly.
3. Create the rear leg assembly by attaching (3) rear cross ties (ref #16) and (1) rear swivel back support bar (ref #10) between the trimmed rear legs (ref #11) using (8) split tee assemblies (ref #18). Use 3-D drawing on page 2 for reference to locate proper placement of cross bars. Next attach (2) 'S' braces (ref #4) between rear legs and attach via clamp tees (ref. #17), again using the 3-D drawing on page 2 for placement reference. Finally, attach (4) split tee assemblies into the (4) remaining open holes of the rear legs, making sure the open T-connectors are facing the pool. The leg with (3) open holes shall be the 'non-ladder side leg'.
4. Slip the clamp flange portion of the anchor deluxe over the bottom ends of the legs. Insert the rear leg assembly into the anchors with the open T-connectors and frame nuts facing the pool. Prop the rear leg assembly in an upright position.
5. Lay the assembled guard rail side frame - 'Left hand side' (ref. #1L) on the ground with the T-connectors facing up. Attach the (2) pedestal cross bars (ref. #6) to the side frame as shown on page 2. Note that T-connectors are assembled at the factory to help in positioning the rails and must be partially removed and re-assembled during installation.
6. Raise this side frame assembly so the pedestal support bar rest on the pedestal cap. They will line up with the front and rear most holes on the pedestal top. Using the superstructure to pedestal mounting hardware (ref. #19), secure the raised side frame assembly to the pedestal.
7. Raise the guard rail side frame - 'Right hand side' (ref. #1R) into position so that it mirrors the already installed left hand side. Secure the right side to the pedestal cross bars with the T-connectors.
8. Attach the rear cross tie (ref. #5) and the rear swivel front support bar (ref. #9) to the assembled side frames using the T-connectors. You may refer to the 3-D drawing on page 2 for location reference. Using a 4' level, verify that the rear swivel front support bar aligns with the rear swivel back support bar (ref. #10) located on the rear leg assembly.
9. Level and square up the assembled superstructure (side frames and rear frame) and make any necessary adjustments. Inspect and tighten all connections made up to this point.
10. Both rear legs (ref. #11) must be drilled for bolts which attach the clamp flanges (already inserted onto legs) to the rear legs. Attach the flange to the socket body with (4) $\frac{3}{8}$ " x $\frac{3}{4}$ " hex head bolts. Drill through the flange cross holes and rear leg with a $\frac{3}{8}$ " drill bit. Bolt together with one $\frac{3}{8}$ " x 3" hex head bolt. Note: Drilling stainless steel requires a very slow speed drill and constant pressure.
11. Connect the step adapter (ref. #14C) to the open split tee on the ladder side of the rear frame assembly. Attach the 26" vertical step (ref. #14B) using the hardware provided and ensure step is level.
12. Lay the left & right ladder risers (ref. #s 2L & 2R) on the ground. Note that the clamp flanges are installed at the factory. Attach the (9) 19" sloping steps (ref. #14A) so that they will be level when the ladder is attached to the tower. Use curved head bolts and washers under the nuts. Secure tightly. **Caution - do not over tighten as this may damage the plastic steps!**
13. Raise the assembly into the ladder opening and attach (hand tight) with clamp tee assemblies (ref. #17).
14. The bottom end of the ladder should be located on the deck per the data sheet (page 1). It should be square to the superstructure and the steps should be level. *It is imperative that the steps remain level.* Attach the flanges to the deck using lags and shields (provided by others).
15. Connect the ladder hand rails (ref. #s 3L & 3R) to the installed ladder risers (ref. #s 2L & 2R) using clamp tee assemblies (ref. #17). to attach hand rails to the rear frame assembly, right guard rail and ladder risers. Keep the hand rails parallel to the risers and to each other. Tighten all ladder connections at this time.
16. Install the Durafirm fulcrum (ref. #15A), Durafirm rear swivel (ref. #15B), and 16' Durafirm diving board per the manufacturer's instructions, as provided by Durafirm, using the hardware provided (ref. #20 & ref. #21).
17. Paint or touch up the pedestal (ref. #7) as needed.

Supersedes Assembly Instructions dated 1/27/1

 <p>PARAGON AQUATICS Pentair Water Commercial Pool & Aquatics</p>	<p>1351 Route 55 LaGrangeville, New York 12540 Phone: 845-463-7200 Fax: 845-463-7291 www.paragonaquatics.com</p>	Dwn by: SF	Date: 2/27/12	<p>Title: 3 Meter Duradapt Diving Tower, Ladder At Side, Flanged Pedestal Assembly Drawing</p>			<p>Material: See Notes/Schedule</p>	
		App by: RV	Date: 2/27/12	Drawing Number: AI-DT10.01S	Tolerance: (Unless noted) N/A	Scale: N/A	Rev Ltr: F	Sheet: 3 of 3