

Quickset® Dual-Wedge™ Anchor

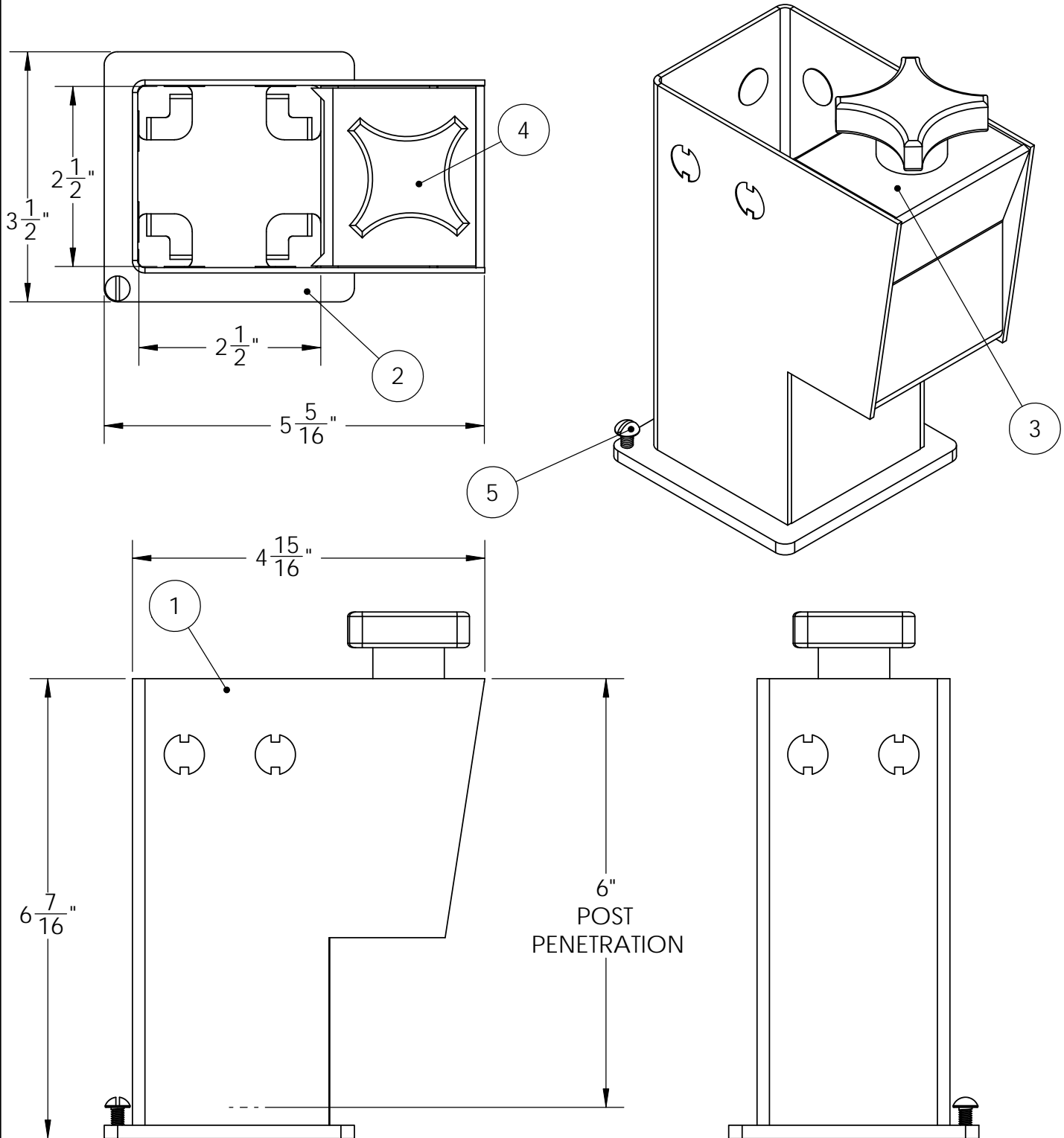

This data represents the latest knowledge available to us at time of presentation. However, Paragon Aquatics and others involved in gathering and presenting this drawing assume no liability for its use.

© 2008 Paragon Aquatics



**PARAGON
AQUATICS**

Pentair Water
Commercial Pool & Aquatics

1351 Route 55
LaGrangeville, NY 12540
Phone: (845) 463-7200
Fax: (845) 463-7291
www.paragonaquatics.com

Drawn By: RV	Date: 7/7/11	Approved By: SF	Date: 7/7/11
Sheet Title: Quickset Dual Wedge Anchor			
Drawing Number: SS-SPA20.90	Revision Letter: B	Sheet: 1 of 2	

Quickset[®] Dual-Wedge[™] Anchor

Part Number: **23302**

Specifications:

- ① The main body of the anchor shall be constructed of 14 gauge T304 stainless steel.
- ② Anchor base shall be Paragon patented taper-lock base to prevent movement of post at the bottom of anchor socket.
- ③ Wedge assembly shall consist of a bronze wedge and T304 stainless steel hardware.
- ④ Anchor shall not require tools to operate. Integrated plastic knob shall allow for tightening of wedge assembly. Wedge Assembly shall be removable for storage inside anchor socket when not in use.
- ⑤ Bonding/ grounding screw shall be provided where grounding and bonding of anchor is required.
- ⑥ Anchor shall be provided with a cover (not shown), that when the anchor is not in use and the wedge assembly is inside the anchor, the cover slips in preventing debris from entering the anchor.

Accessories:

Item Number	Description
23304	Replacement Wedge Assembly
22213	Anchor cover

This data represents the latest knowledge available to us at time of presentation. However, Paragon Aquatics and others involved in gathering and presenting this drawing assume no liability for its use.

© 2008 Paragon Aquatics



**PARAGON
AQUATICS**
Pentair Water
Commercial Pool & Aquatics

1351 Route 55
LaGrangeville, NY 12540
Phone: (845) 463-7200
Fax: (845) 463-7291
www.paragonaquatics.com

Drawn By: RV	Date: 7/7/11	Approved By: SF	Date: 7/7/11
Sheet Title: Quickset Dual Wedge Anchor			
Drawing Number: SS-SPA20.90	Revision Letter: B	Sheet: 2 of 2	