

AQUATRAM PT-2

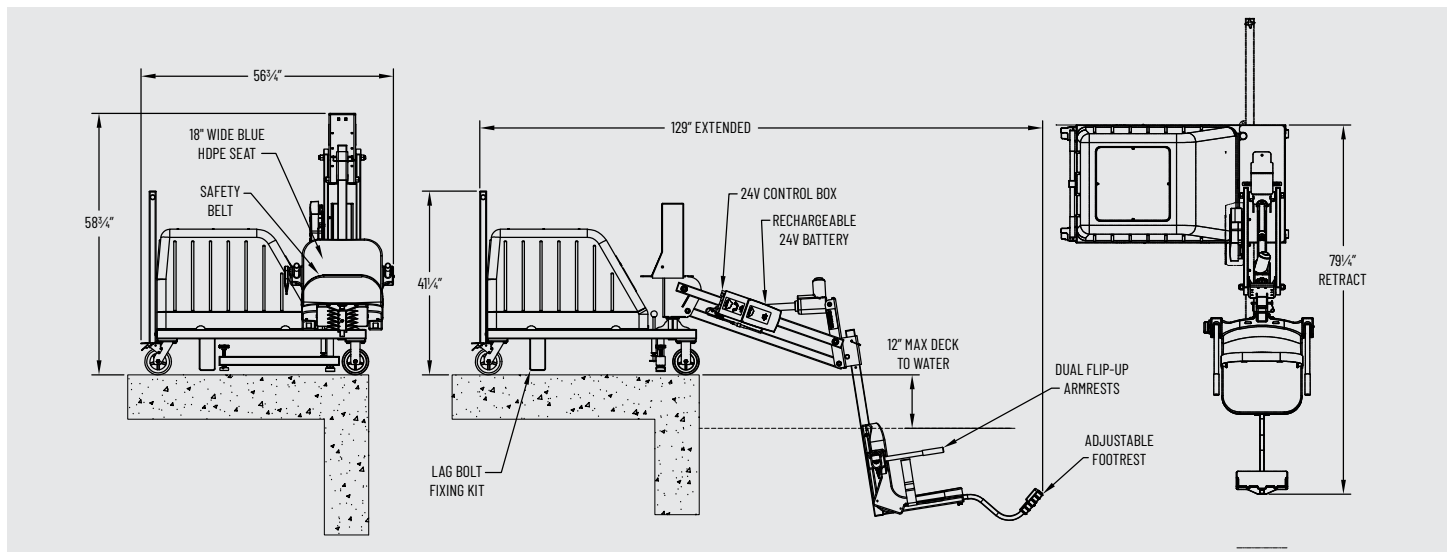

Features and Benefits

1. Mobile swimming pool access stores off-deck when not in use.
2. Highly maneuverable. Fits through most doorways.
3. ADA-Compliant with the use of the Affixment Kit (included). Docking Bar and anchor "affix" the lift in place during operating hours. Kits can be installed at various locations.
4. Standard model (11480) is counter-weighted using sand ballast. Sand can be sourced locally, saving substantial freight cost. 325-lb. lifting capacity.
5. Accommodates most pools with a "deck-to-water" dimension of up to 12".
6. Dual flip-up armrests provide easier access and safer transfers on the pool deck and in the water.
7. Comfortable seat has an adjustable lap belt with hook-and-loop fasteners, plus an adjustable and removable footrest.
8. Simple 4-button submersible handset lets the user rotate and raise and lower while seated or from the pool edge.
9. Rechargeable battery-powered operation is easier to install than water-powered lifts; provides a smoother ride, greater reliability and easier servicing with plug-and-play components.

