

AQUATRAM[®]

ADA-COMPLIANT POOL ACCESS LIFTS

AQUATRAM 360 LIFT

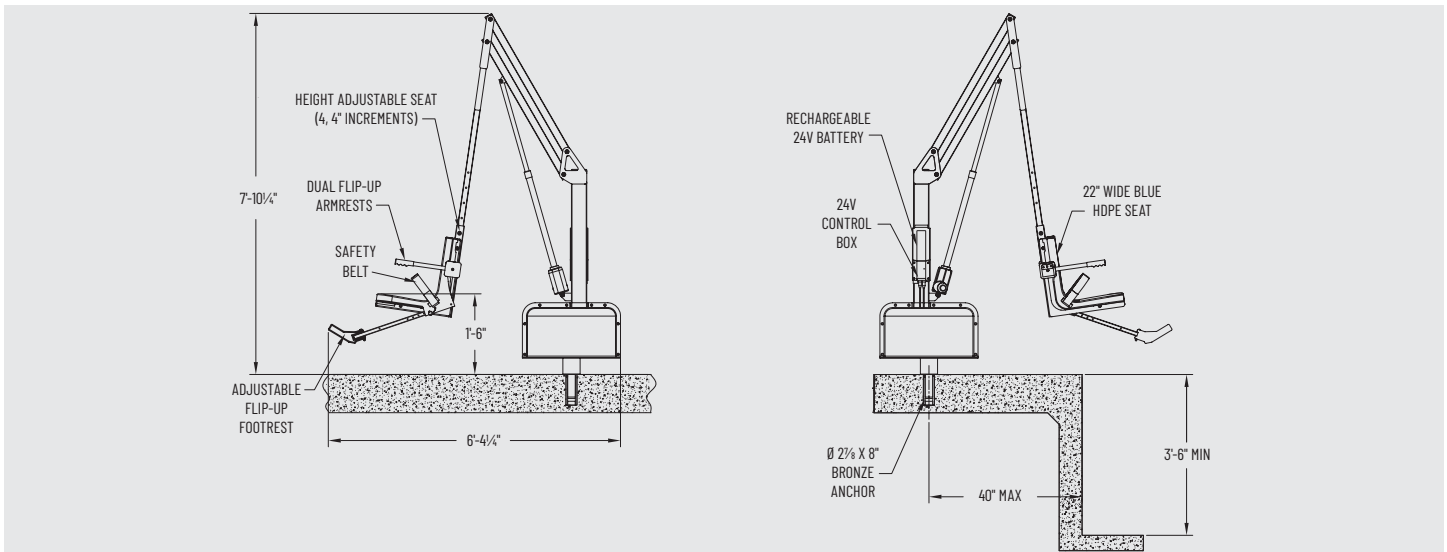

Features and Benefits

1. ADA-Compliant; lifting capacity: 500 lbs.
2. Versatile boom arm design accommodates anchor set-back distances up to 40"; clears walls up to 30" high and 10" wide; and can serve two adjoining pools from the same install location.
3. 360° unimpeded rotation in either direction allows access to and from the lift, even in small areas.
4. Dual flip-up armrests provide easier access and safer transfers on the pool deck and in the water.
5. Comfortable seat has an adjustable lap belt with hook-and-loop fasteners, plus an adjustable and removable footrest.
6. Simple 4-button submersible handset lets the user raise, lower and rotate while seated or from the pool edge.
7. Removes without tools, and moves easily with the optional transport cart. Multiple anchors can be installed in various locations around the pool to accommodate the pool's scheduled activities.
8. Stainless steel construction with corrosion-resistant, powder-coat finish.
9. Rechargeable battery-powered operation is easier to install than water-powered lifts; provides a smoother ride, greater reliability and easier servicing with plug-and-play components.

