

WLC-100 & 200-4

**AUTOMATIC
WATER LEVEL
CONTROLLER**

**INSTALLATION
AND
OPERATION
INSTRUCTIONS**

MODEL WLC-100 & 200-4 AUTOMATIC WATER LEVEL CONTROLLER INSTALLATION & OPERATION INSTRUCTIONS

WLC-100 & 200-4.doc The Neptune-Benson WLC-100 & 200 package consists of two basic assemblies:

- 1a. For the WLC-200 - 1.5" clear PVC control chamber, including three stainless steel probes, one thermoplastic 3 probe holder with cover, one stainless steel mounting bracket and two PVC control chamber securing brackets.
- 1b. For the WLC-100 - PVC control chamber, including stainless steel probes, probe holders and covers, chamber cover, adjustable collar and probe holder plate.
2. Nema 4X enclosed control panel, including liquid level relay, delay timer, 24-hour (120V) clock timer and terminal board.

1a. The WLC-200 chamber should be installed during construction with the elevation such that the optimum pool water level falls within the range of the low and high level probes (*Refer to WLC-200 Water Level Controller Figure 2 page 9*). The top of the clear plastic pipe should be at least 2" above the maximum water level in the pool. The probes are provided longer than required and should be sized in the field after the chamber is positioned. **Do not** cut the probes to size until reading **all** instructions.

1b. The WLC-100 chamber is designed for installation in the deck adjoining the pool or within the filter room area. The PVC control chamber should be installed during construction with the elevation such that the optimum pool water level falls within the range of the low and high level probes (*Refer to WLC-100 Water Level Controller Figure 3 page 11*). The probes are provided longer than required and should be sized in the field after the chamber is positioned. **Do not** cut the probes to size before reading **all** instructions.

The WLC control panel is a very sensitive unit that can control the pool water level within 1/32" tolerances. The design of the unit allows a range of adjustment without having to again cut or reposition the probes. Changing conditions requiring different levels of pool water can be accommodated with no change in equipment or replacing of probes, unless the change is drastic, in which case new probes might be required.

Properly installed, the system works as follows: the water level equalizing line between the pool and the control chamber provides a direct connection to the pool so that when the water level in the pool drops, so will the level in the chamber. When the level drops low enough to expose the bottom of the low level probe, a signal is sent to the control panel which, in turn, activates and opens the make-up solenoid valve. If the make-up water comes from another source, this system can activate any device using a 120 volt circuit (220 volt also available if required). The water level in the pool and the control chamber will rise to a point when the bottom tip of the high level probe will come into contact with the water. This contact will initiate another signal that will activate the 0 - 30 minute adjustable delay timer. The make-up water will continue to flow into the pool until the pre determined time cycle set on the delay timer elapses. At that point, the solenoid valve will shut with the pool water level being at the desired level.

Because the WLC has the ability to "fine tune" the level of water in the pool, any activity in the pool would move or vary the water level sufficiently to activate the system. Such a signal would provide false information and unnecessarily add water to the pool. Because of this, the WLC package includes a 24-hour timer which can be set to activate the system at specific hours when the pool is not in use and the pool surface is very calm. This time clock is fully adjustable in 30-minute increments and may be changed at any time to suit changing needs or requirements.

MODEL WLC-100 & 200-4 AUTOMATIC WATER LEVEL CONTROLLER INSTALLATION & OPERATION INSTRUCTIONS

WIRING THE CONTROLLER SYSTEM

Install and wire the controller panel to an independent 15 amp / 120V circuit, include an on/off switch for isolation purposes. In all installations a good external ground connection and a dependable return circuit to the liquid are required. Because the probe chamber is non-metallic a third probe or electrode is provided for grounding. The control panel should be suitably grounded. Electrical conduit should not be used for this purpose.

The ground probe should be connected as shown on (*WLC-100-4 Water Level Controller Wiring Diagram Figure 1 page 8*). The control panel should be grounded in accordance with local electrical codes.

Shielded cable is not required and ordinary insulated wire (#14 to #18 GA) can be used for electrode leads. Lead wires should be isolated from power and load carrying circuits (not run in the same conduit) to avoid direct coupling with these circuits. While capacitance of the lead wire to ground has some slight effect on sensitivity, this factor need only be considered when relay (control panel) is located more than 1000 feet away from the probes. When wiring to the CE-3 probe holder, provide a 12" loop of flexible wires to facilitate removal of the probe holder without the necessity of disconnecting the probes from the probe holder.

SETTING THE 24 HOUR TIMER

Rotate the timer face clockwise to the present time. Extend all of the orange pins corresponding to the time that the pool is **not** in operation. This will allow the controller to operate only during this period of non-use. The remaining depressed pins will indicate periods the controller is not in operation.

The internal wiring of the control panel is such that non-operation will cut off service to the solenoid valve while the clock function of the 24-hour timer will continue to operate and indicate the current time.

SETTING THE PROBES

Three probes are provided with this package. The probes should be hand threaded into the probe holder. The low-level probe should be cut so that the bottom or free end of the probe should be at the same elevation as the lowest allowable level of water in the pool. This means that any further drop in water level in the pool will result in activating the make-up water system. The correct length of probe can be determined by actually lowering the pool water level to the lowest allowable point. The water level in the control chamber will indicate the point at which to cut the probe. The ground probe should be ½" longer than the low-level probe and without touching the bottom of the control chamber.

MODEL WLC-100 & 200-4 AUTOMATIC WATER LEVEL CONTROLLER INSTALLATION & OPERATION INSTRUCTIONS

After setting the low-level probe, raise the pool water level to a point approximately ½” below the actual top edge of the gutter or desired water level. We suggest this dimension since most pool gutters vary slightly in elevation along the top edge. The high level probe should be threaded into position, marked, then remove and cut the probe at that dimension. When cutting the probes use a non-ferrous cutting blade or disc. Round off all sharp edges after cutting.

Further adjustment or elevation setting of the probes can be made by moving the slotted stainless steel mounting bracket up or down.

Verify continuity of wiring before re-installing the probes. Be sure to secure the correct probe to the proper connection on the probe holder so that each probe corresponds to the matching high level, low level and ground connections on the control panel terminal strip. Tighten probes by hand until the securing ‘O’ rings lock the probes in position. **Cut (3) 1” lengths of 1/4” poly tubing (provided), slice them down the 1” length, and wrap around each probe to prevent them from touching one another.**

DELAY TIMER

The DT Model GT3A delay timer has variety of time settings available. For this application the timer has been factory set for 0 – 30-minute range. Verify this setting by visually inspecting the setting on the timer. They should read:

1. Operation Mode ‘A’ setting for ON delay
2. Time Range Selector ‘10M’ setting
3. Dial Selector ‘0-3’ setting

If the delay timer settings concur with the above, the unit will provide a range of 0-30 minutes by rotating the setting knob from 0 to maximum. If the delay timer is not set correctly, refer to manufacturer’s literature and set accordingly.

After verifying the above, set the delay timer knob to “maximum”. The delay timer will allow the water level to continue to rise in the pool. When the water reaches the desired level turn the delay timer knob back towards zero until the solenoid valve shuts off. The next cycle will now operate on this time cycle. If this additional fill time is not required, set the knob to zero. Note that if power is lost at this unit, the delay timer will activate when re-powered and fill for the set time.

Further adjustment or elevation setting of the probes can be made by moving the slotted stainless steel mounting bracket up or down.

The controller is now ready to operate automatically. Contact your area representative or Neptune-Benson at 1-800-832-8002 for assistance.

MODEL WLC-100 & 200-4
AUTOMATIC WATER LEVEL CONTROLLER
INSTALLATION & OPERATION INSTRUCTIONS
TROUBLE SHOOTING WLC MODELS 100 & 200-4

INTRODUCTION

Trouble shooting any equipment requires you to be familiar with the sequence of operation of that equipment. In addition you should read and become familiar with Installation and Operating Instructions to compare normal operation with the potential problem you might encounter. Sequence of operation follows below:

A drop in water level exposing the bottom of the lower probe will activate LLR relay (LED red light goes on). Relay continues to be activated until rising water touches the upper probe. LLR relay will then open, shutting LED red light and activating delay time (DT). 'ON' green light will illuminate. Delay timer will remain powered for the selected time, keeping the solenoid valve activated and allowing make-up water to flow into the pool. At the end of the timed period the power 'OFF' red light will go on with the solenoid valve de-activating (closing). Both lights on the DT will remain lit until there again is a need for water in the pool.

The above sequence will operate only if the 24-hour timer is in the 'ON' position. If the 24-hour timer is in the 'OFF' position the relay will operate as if activated, but the solenoid valve will not be energized.

TROUBLE SHOOTING

System can be checked by lifting the probes out of the water. This will initiate the sequence of operation since it has the same effect as if the system is calling for water. The probes are not electrically energized so there is no hazard when removing the probes from the chamber. Removing the probe assembly will facilitate re-installation. Do not disconnect individual probes from holder(s).

NOTE: As with any other electrical device, all connections should be checked for loose wires. All timers, relays and 24 hour clocks need to be checked that they are securely mounted.

TO TEST PANEL

Turn power off to panel.

Make sure that the GT3A Timer (Delay Timer) is set to "0".

Make sure that the pins on the 24 hour clock are all to the outside circumference of the clock (to allow a fill)

Disconnect probe wires from panel.

Install (2) 6" long 16 gA. wires into terminal #15 (ground probe).

Install the end of one of the wires into terminal #14 (low level) and install the end of the other wire into terminal #13 (high level).

This should simulate a full chamber.

Turn the power back on to the panel (nothing should happen)

Now disconnect the wire from terminal #13 (this would simulate the water dropping below the high level probe).

Nothing should happen. (continued on next page)

MODEL WLC-100 & 200-4
AUTOMATIC WATER LEVEL CONTROLLER
INSTALLATION & OPERATION INSTRUCTIONS
TROUBLE SHOOTING WLC MODELS 100 & 200-4

Now disconnect the wire from terminal #14 (this would simulate the water dropping below the low level probe).

The RED light on the Liquid Level Relay should come on and there should be voltage across terminals #2& #3 (where the solenoid valve is wired in).

Now put the wire back into terminal #14 (simulating the water filling up and going past the low level probe.)

Nothing should happen.

Now put the wire back into terminal #13 (simulating that the water has hit the high level probe).

The RED light on the Liquid Level Relay should now go off.

LLR RELAY

Verify that the 24-hour timer is in the 'ON' position. If the system is calling for water, the LLR relay should be activated. This will be evident by illumination of the LED red light inside the relay. If the light does not go on, check the voltage to the unit by placing the tester leads across lugs 2 and 7 on the LLR base. If the tester indicates 120 volts and the light is not on, replace the relay. For additional trouble shooting refer to manufacturer's literature for Series 16M control (form 167) for INVERSE MODE operation.

DT DELAY TIMER

The DT delay timer is energized only after the LLR relay has been activated, and with the water level rising, subsequently de-activated. The de-activation of the LLR relay should activate the DT timer.

Setting the knob below the 'OFF' position can fault the sequence. For test purposes set the knob just above the off or zero position. At this setting the 'out' red light (power off position) will go on shortly after the 'power' red light (power on position) indicating that the delay timer is functioning. If neither light goes on use the 120 volt tester to verify voltage to the DT timer by placing the test leads across lugs 2 and 7 on the base of the DT timer. Initiate operation again by removing the probes from the water. This will activate the LLR relay. Place the probes back into the water. This will de-activate the LLR relay and activate the DT delay timer. At this point the 120 volt test should indicate 120 volts. If tester indicates 120 volts and the power (red light) is not illuminated, replace the DT timer.

**MODEL WLC-100 & 200-4
AUTOMATIC WATER LEVEL CONTROLLER
INSTALLATION & OPERATION INSTRUCTIONS
TROUBLE SHOOTING WLC MODELS 100 & 200-4**

SOLENOID VALVE TESTING

If the solenoid valve is not activating as required, but with the indicator light on the level relay in working order, verify the following:

Check to make sure the 24-hour timer is in the 'ON' or operating position with the correct time of day indicated on the dial. Rotating the timer to simulate an 'ON' position can be done at anytime. Remember to return the timer to the correct time of day after testing.

Using a standard 120 volt tester verify operation by attaching the tester leads to numbers 2 and 3 on the controller terminal strip. If the system is calling for water and the 24-hour timer is in the 'ON' position, the tester should indicate 120 volts. If 120 volts is evident and the solenoid valve is not working, further testing of the solenoid valve and wiring are necessary.

Using the same tester, continue the above procedure by placing the tester leads across the connection to the solenoid valve. If the tester is energized indicating 120 volts and the solenoid valve is not working, the valve itself will have to be tested for suitability. If the tester is not activated, you will have to verify continuity of the lines feeding the valve.

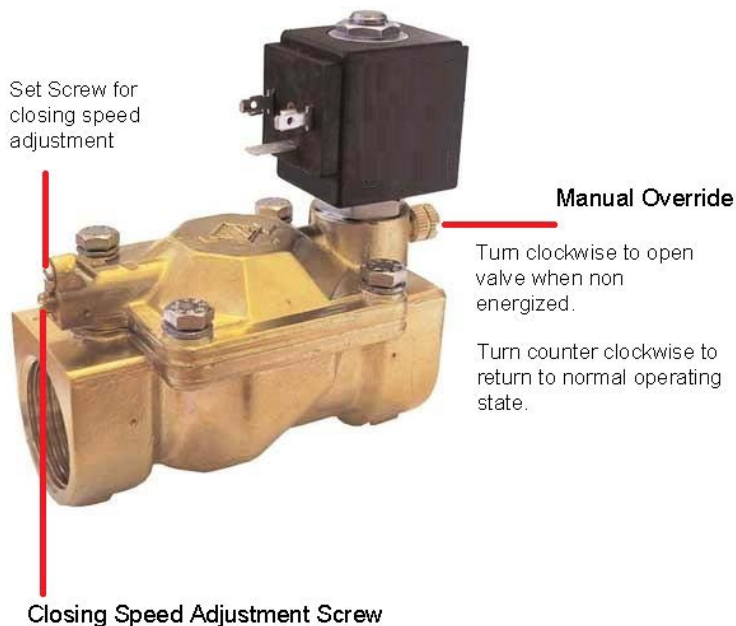

Thread into the valve in a clockwise rotation until desired closing speed is found.

**MODEL WLC-100 & 200-4
AUTOMATIC WATER LEVEL CONTROLLER
INSTALLATION & OPERATION INSTRUCTIONS
TROUBLE SHOOTING WLC MODELS 100 & 200-4**

PROBES

The quality of the water will affect the probes. If the probes become pitted or coated, the conductivity of the system can fault and possibly reduce or eliminate the sensitivity of the system. Regular preventative maintenance should include cleaning of the probes. A non-metallic cloth or 'Scotchbrite' pad should be used for the purpose. The bottom two inches of each probe, in particular, should be kept clean. Of course all wiring and connections should be checked as well. When servicing the probes it is recommended that the 120 volt power to the programmer be in the 'OFF' position.

24-HOUR TIMER

The 24-hour timer is basically a clock with pins. When the pins are pulled to the inside diameter, the load side of the timer is not active. When the pins, corresponding to the desired 'ON' time, are pushed to the outside diameter, the load side of the clock will be activated and will provide available power to the solenoid valve at those times.

If the 24-hour timer is in the 'ON' position and the system is calling for water, placing the test leads across lugs 2 and 3 of the 24-hour timer should read 120V. If there is no reading across lugs 3 and 4 at this point, the 24-hour timer should be replaced.

The 24-hour timer is powered by a small synchronous motor. If the timer does not rotate or keep good time, it should be replaced.

MODEL WLC-100 & 200-4 AUTOMATIC WATER LEVEL CONTROLLER INSTALLATION & OPERATION INSTRUCTIONS WIRING DIAGRAM

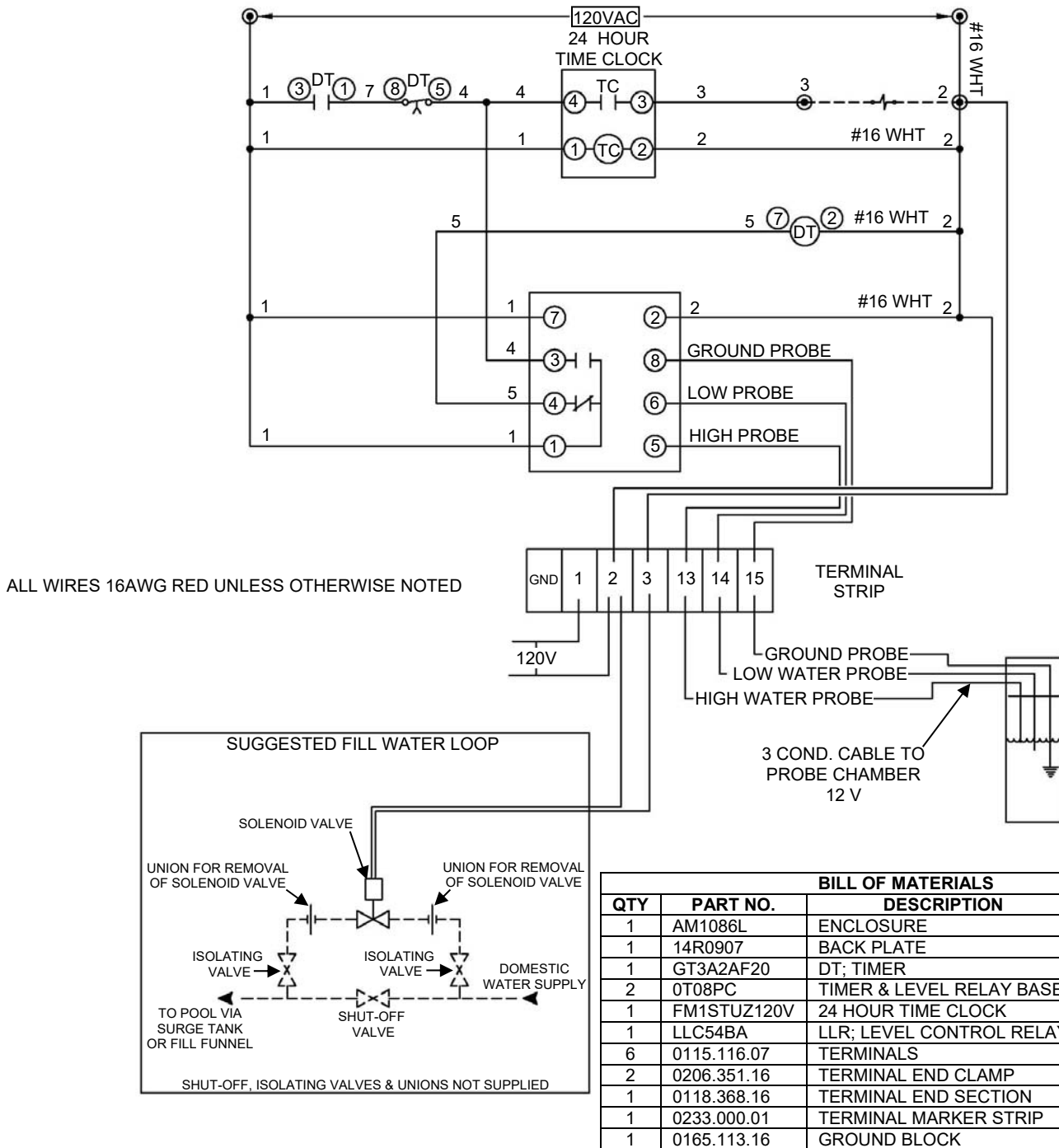

FIGURE 1

**MODEL WLC-100 & 200-4
AUTOMATIC WATER LEVEL CONTROLLER
INSTALLATION & OPERATION INSTRUCTIONS**

NO.	QTY	DESCRIPTION	PART #
1	1	WLC PROBE HOLDER CE-3	135000CE-3
2	1	WLC BRACKET MOUNTING SLOTTED	135WLCBRKT
3	1	WLC PROBE – 1' LONG S.S.	1350SSP6B1
4	1	WLC PROBE – 2' LONG S.S.	1350SSP6B2
5	1	WLC PROBE – 3' LONG S.S.	1350SSP6B3
6	1	PIPE SCH 40 PVC 1.5"	23115CLEAR
7	1	FITTING BULKHEAD - .75" PVC	14075BHFIT
8	2	CLIC CLAMPS 1.5"	221150CLIC
9	1	1 1/2" FEMALE ADAPTER SLIP X FPT 1.5"	220835-015
10	3 PCS	TUBING DISCHARGE - .375" O.D. - POLYETHYLENE PROBE SLEEVE – NOT SHOWN	1350375DIS

WLC-200 INSTALLATION ARRANGEMENT

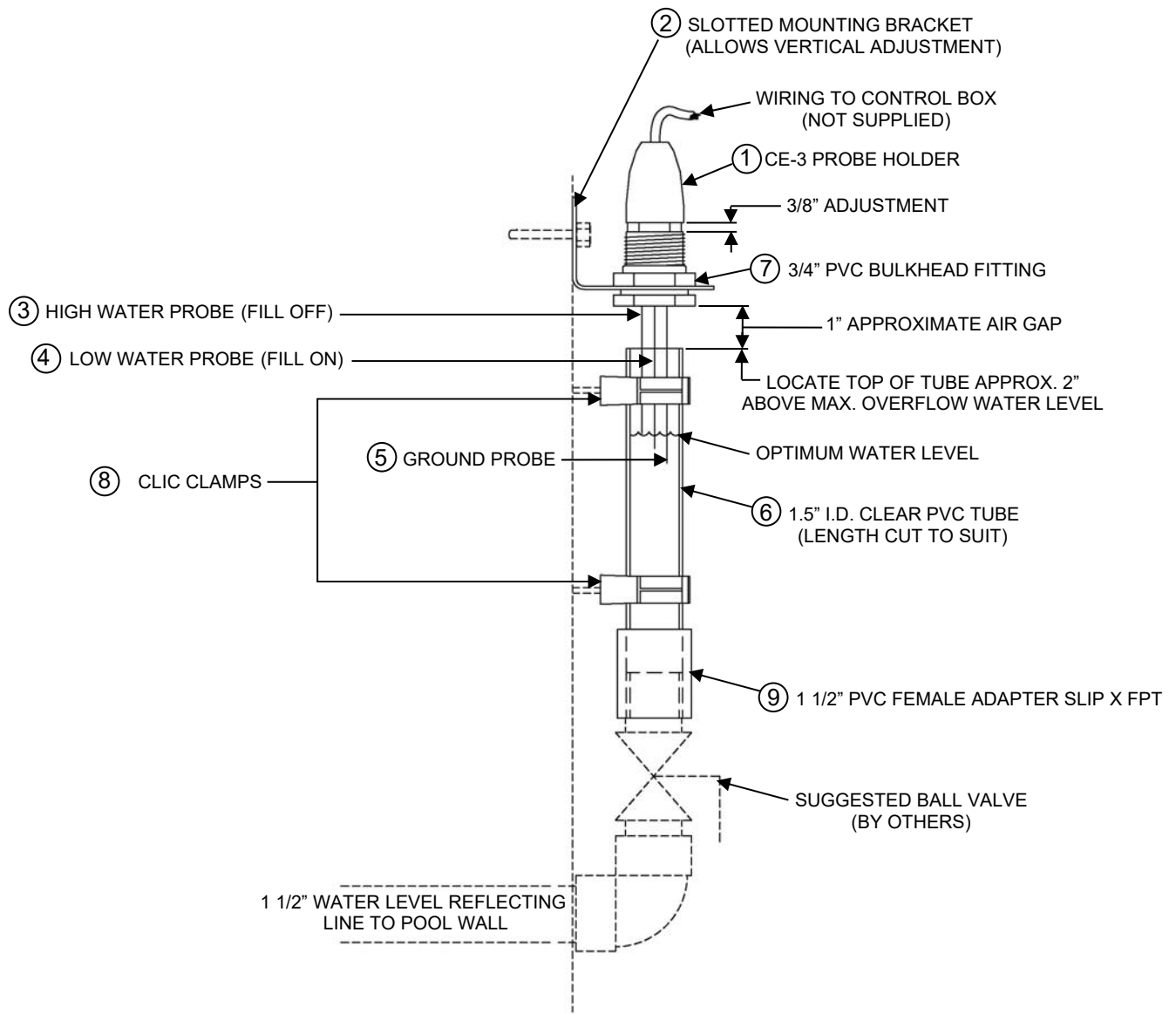
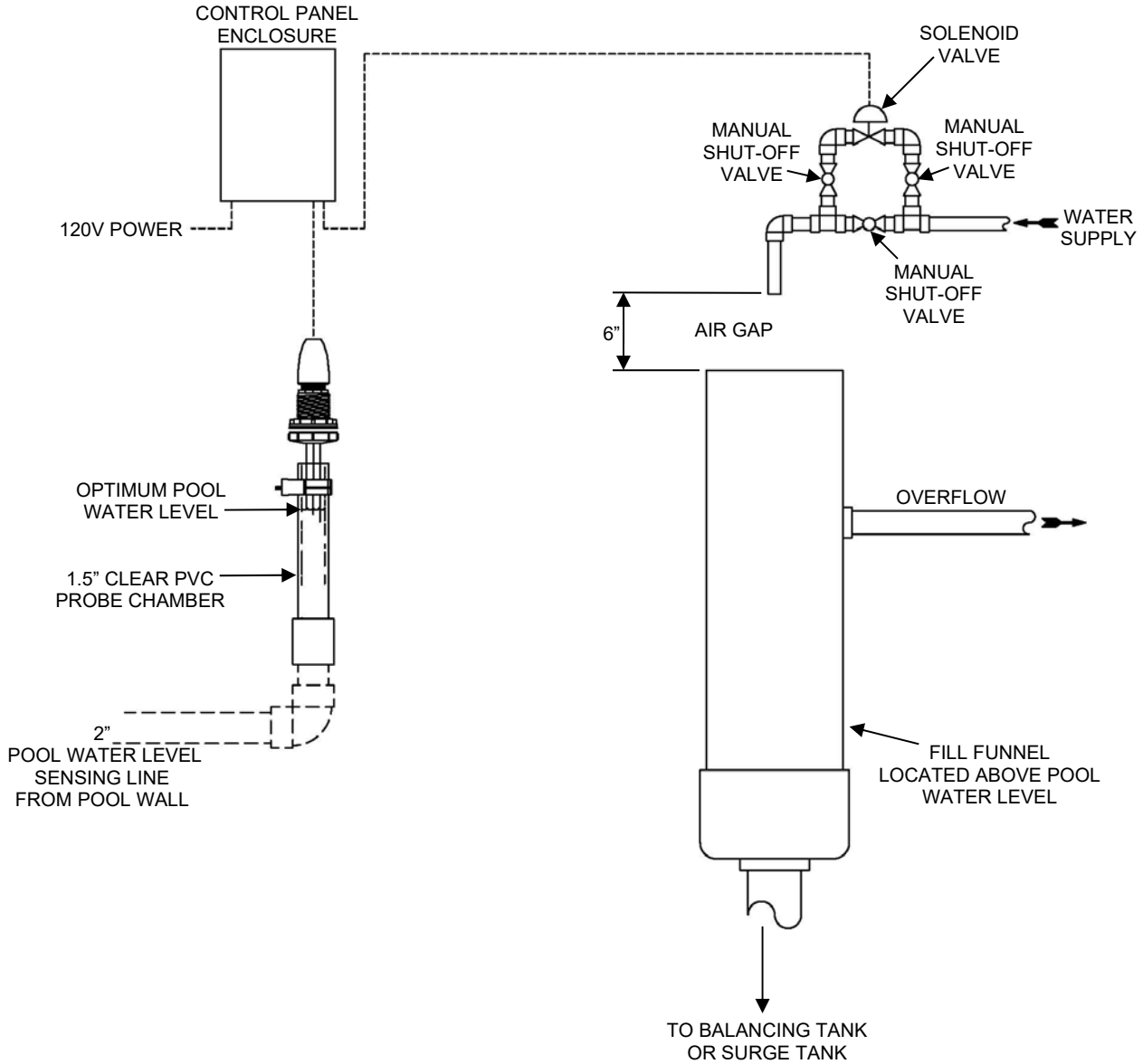

FIGURE 2

**MODEL WLC-100 & 200-4
AUTOMATIC WATER LEVEL CONTROLLER
INSTALLATION & OPERATION INSTRUCTIONS**

WLC-200 INSTALLATION ARRANGEMENT



**MODEL WLC-100-4 & WLC-200-4
AUTOMATIC WATER LEVEL CONTROLLER
INSTALLATION & OPERATION INSTRUCTIONS**

NO.	QTY	DESCRIPTION	PART #
1	3	WLC PROBE - 1' LONG S.S.	1350SSP6B1
2	3	CONNECTOR MALE COMP. .250 X .375 TUBE X MPT	13525X375COMP
3	1	WLC CHAMBER COVER W / COLLAR	1358650169
4	1	WLC CHAMBER ONLY	135WLCCHMB
5	3	SCREW PAN HEAD 6-32 X .187" T304 SS MALE THREAD	12439
6	3	CONNECTOR CRIMP RING #6	12437

WLC-100 INSTALLATION ARRANGEMENT

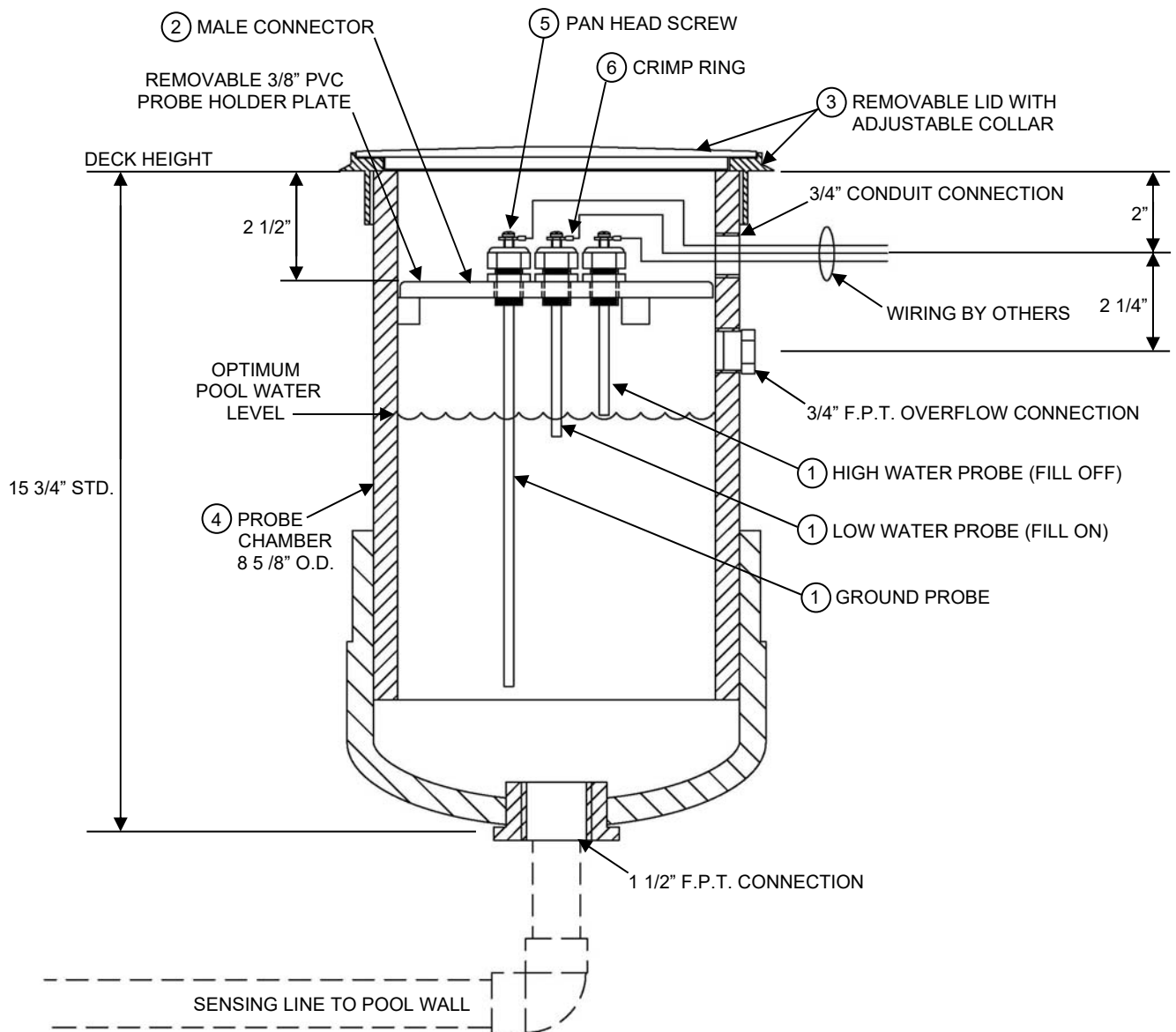
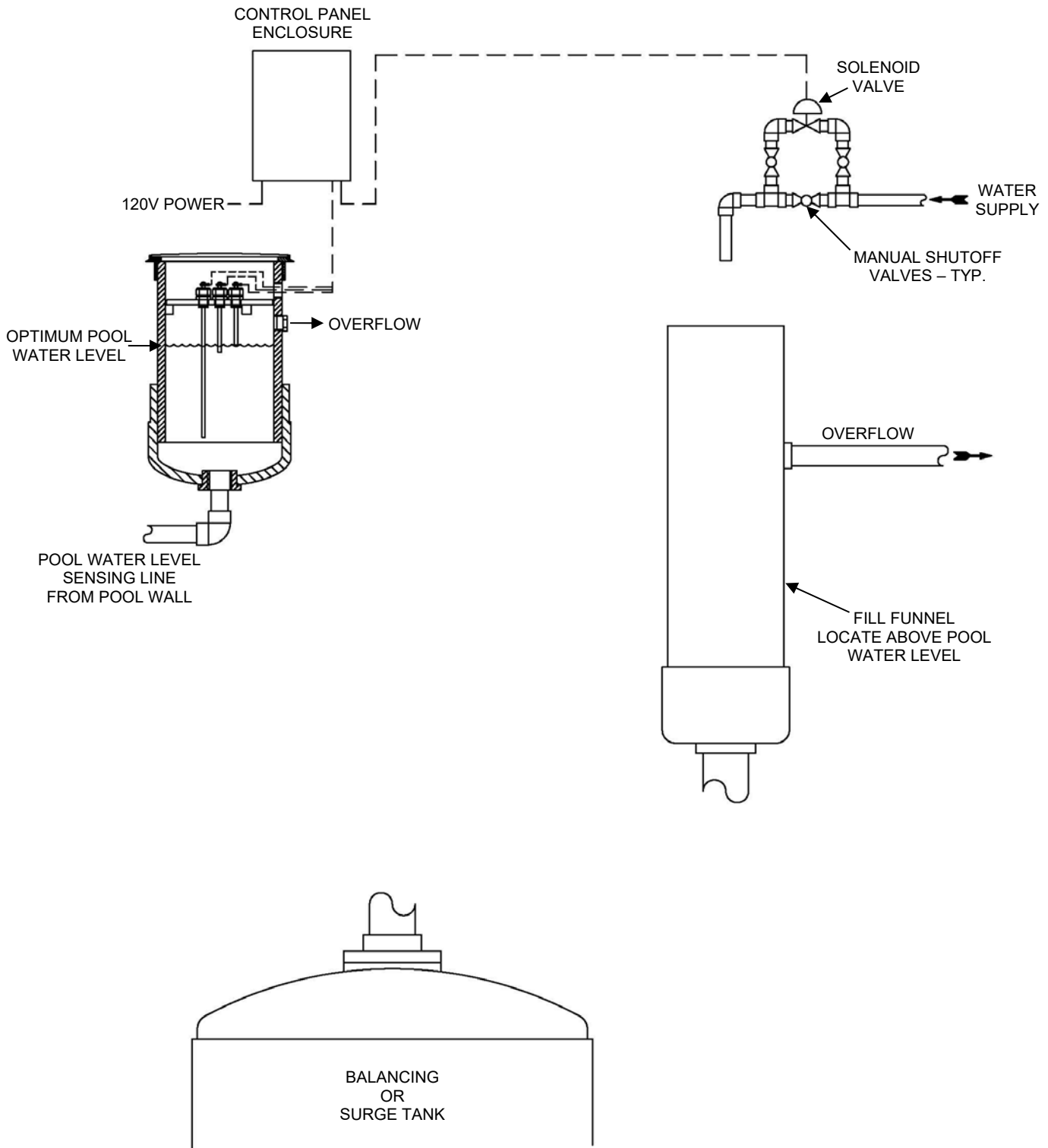

FIGURE 3

MODEL WLC-100-4 & WLC-200-4 AUTOMATIC WATER LEVEL CONTROLLER INSTALLATION & OPERATION INSTRUCTIONS

WLC-100 INSTALLATION ARRANGEMENT



**MODEL WLC-100-4 & WLC-200-4
AUTOMATIC WATER LEVEL CONTROLLER
INSTALLATION & OPERATION INSTRUCTIONS**

BILL OF MATERIALS			
MARK	QTY	DESCRIPTION	PART NUMBER
1	1	24 HOUR TIME CLOCK - FM1STUZ120V	11237
2	1	LLR; LEVEL CONTROL RELAY- LLC54BA	-
3	1	DT; TIMER – GT3A2AF20	1501HRTMER

WLC-100 & 200-4 CONTROL PANEL

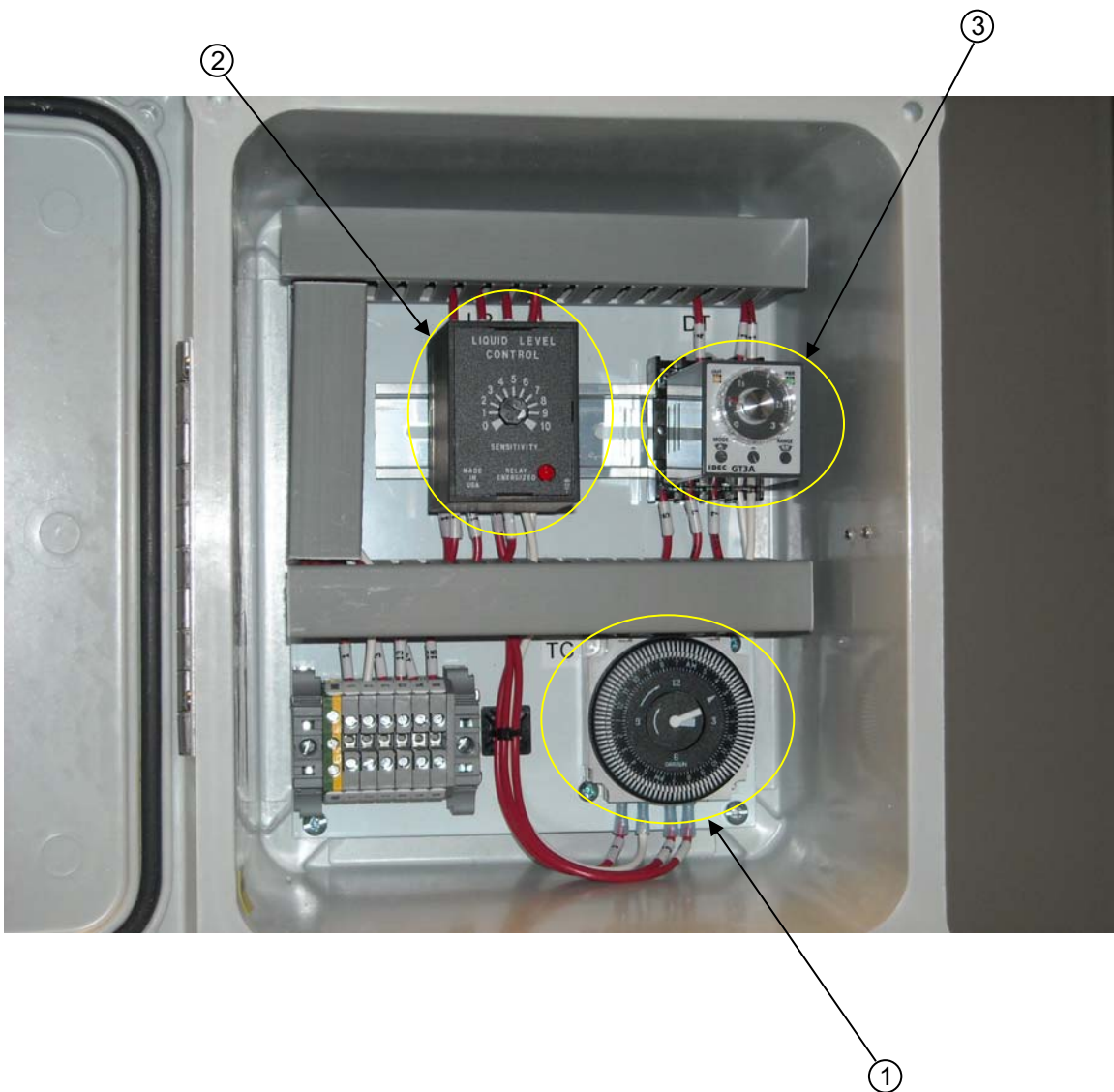

**MODEL WLC-100 & 200-4
AUTOMATIC WATER LEVEL CONTROLLER
INSTALLATION & OPERATION INSTRUCTIONS**

The Water Level Controller is provided with a 24 hour clock to isolate operation of the water level control to a certain time of day such as night time when the pool is not in use.

The clock is fully adjustable in 15 minute increments and may be changed at any time. Activity in the pool can cause false level readings activating the pool fill and over filling. When the filter backwashes, the water goes to waste lowering the level in the pool.

To set the clock to the preset time of day, rotate the minute hand clockwise to the present time and the timer face will also rotate until the correct time is aligned with the indicator arrow.

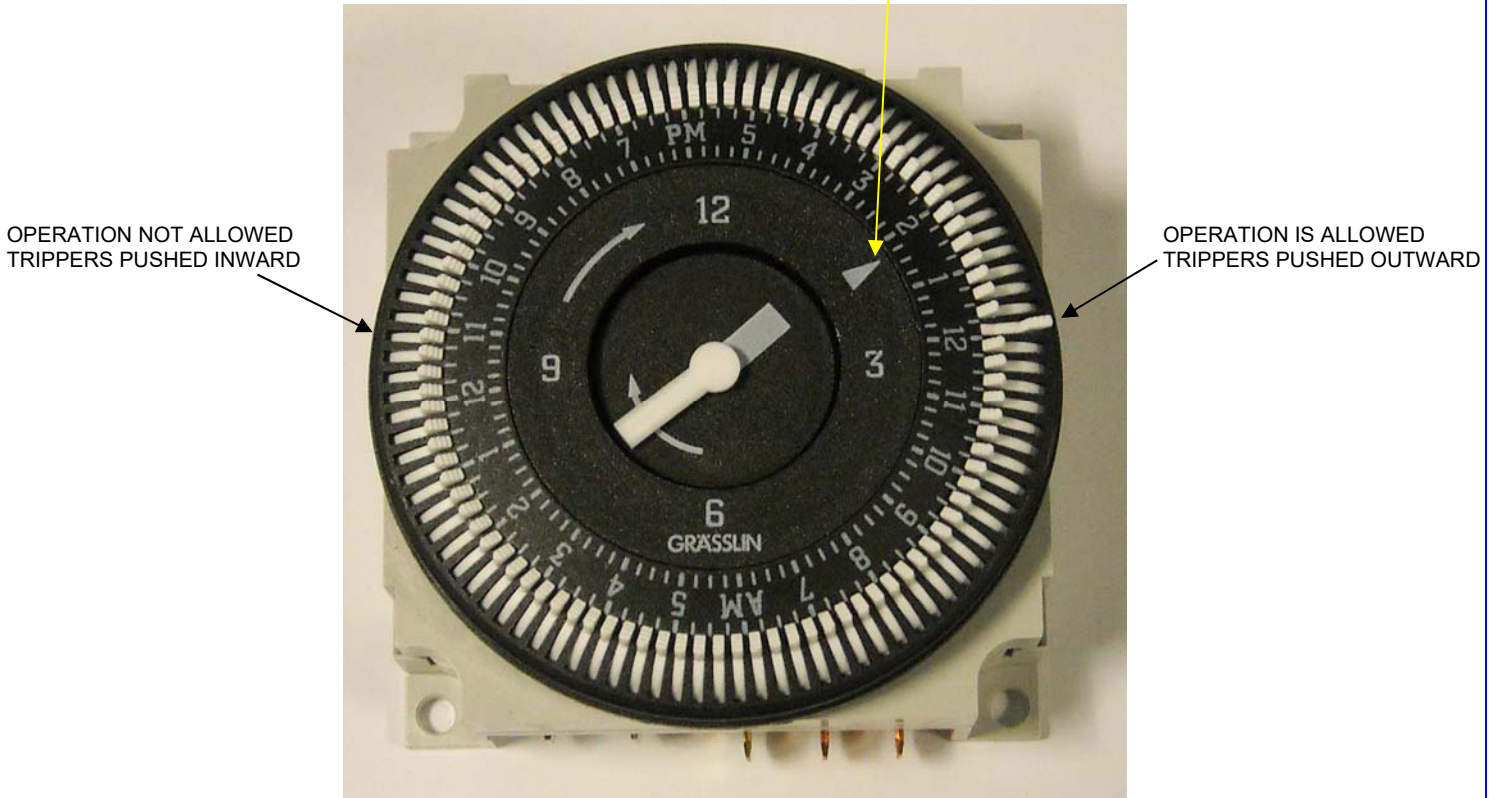

To set the clock to allow operation at a certain time, pull out the trippers corresponding to the time of day the operation is desired. The remaining pins are to be pushed inward, disallowing the operation during the rest of the day.

**MODEL WLC-100 & 200-4
AUTOMATIC WATER LEVEL CONTROLLER
INSTALLATION & OPERATION INSTRUCTIONS**

DT TIMER - MODEL GT3A-2AF20

WLC-100 & 200 WATER LEVEL CONTROLLERS
(0 - 30 MINUTES) OF EXTENDED WATER FILL

- OPERATION MODE = ON DELAY
- RATED VOLTAGE (AF20) = 100 TO 240 VAC (50/60 HZ)
- TIME RANGE = 18 SECONDS TO 30 MINUTES
- OUTPUT = 240 VAC, 3A; 120 VAC / 24 VDC, 5A (RESISTIVE LOAD)
- CONTACT = DELAYED SPDT + INSTANTANEOUS SPDT



SETTING KNOB – FIELD SET

18 SEC. TO 30 MIN. WITH DIAL SELECTOR @ 0-3
36 SEC. TO 60 MIN. WITH DIAL SELECTOR @ 0-6

TIME RANGE SELECTOR (10M) – FACTORY SET

DIAL SELECTOR (0-3) – FACTORY SET

OPERATION MODE SELECTOR (A) – FACTORY SET