

WARNING / ATTENTION / AVISO

STOP!
READ
FIRST

Read and Follow All Instructions. Failure to Follow Instructions can cause Severe Injury or Death.

Suction Entrapment Hazard: Suction in suction outlets and/or suction outlet covers which are damaged, broken, cracked, missing, or unsecured can cause severe injury and/or death due to the following entrapment hazards:

Hair Entrapment- Hair can become entangled in suction outlet cover.

Limb Entrapment- A limb inserted into an opening of a suction outlet sump or suction outlet cover that is damaged, broken, cracked, missing or not securely attached can result in a mechanical bind or swelling of the limb.

Body Suction Entrapment- A negative pressure applied to a large portion of the body or limbs can result in an entrapment.

Evisceration/ Disembowelment Entrapment- A negative pressure applied directly to the intestines through an unprotected suction outlet sump or suction outlet cover which is damaged, broken, cracked, missing, or unsecured can result in evisceration/disembowelment entrapment.

Mechanical Entrapment- There is a potential for jewelry, swimsuits, hair decorations, finger, toe or knuckle to be caught in an opening of a suction outlet cover resulting in mechanical entrapment.



To Reduce the Risk of Entrapment Hazards:

- A minimum of two functioning suction outlets per pump must be installed. Suction Outlets in the same plane (i.e. Floor or wall), must be installed a minimum of three feet [1 meter] apart, from near point to near point.
 - Dual suction fittings shall be placed in such locations and distances to avoid "dual blockage" by a user.
 - Dual suction fittings shall not be located on seating areas or on the backrests for such seating areas.
 - The maximum system flow rate shall not exceed the rating of any listed (per ASME/ANSI A112.19.8M-1987, ASME A112.19.8M-2007) suction outlet cover installed.
 - Never use Pool or Spa if any suction outlet component is damaged, broken, cracked, missing or not securely attached.
 - Replace damaged, broken, cracked, missing, or not securely attached suction outlet components immediately.
 - In addition to two or more suction outlets per pump installed in accordance with the latest APSP standards and CPSC guidelines, follow all National, State, and Local codes applicable.
 - **CAUTION** - Do not exceed maximum flow rate stated on suction fitting.
- When replacing pump, use pump with similar flow curve and horsepower.

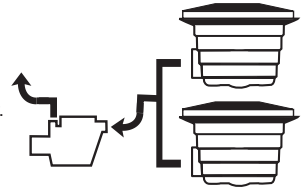



WARNING / ATTENTION / AVISO

REPLACEMENT

Instruction for Installation into Existing Concrete Ledge or Frame.

Model # MLD-FGD-1818 SUBMERGED SUCTION OUTLETS

MAXIMUM RATED FLOW RATES –ACCEPTABLE PIPE SIZE
FLOOR: 816 GPM; WALL: 712 GPM – 8 INCH

Read instructions before installing. This cover must be properly installed using supplied brass screws. When using other than the supplied frame and fasteners, the design professional certifying the sump must also approve the type and installation of frame and fasteners used. Close pool immediately if cover breaks or becomes loose and replace with a new cover. Failure to maintain cover can result in severe injury or death.

- When installing the grate without using the supplied frame, the grate must be anchored into a solid concrete base using the fasteners provided.
- Use grate to locate and mark the 4 anchoring positions.
- Using a 5/16" concrete bit; drill the 4 holes to a depth of 1". Use caution. Do not over drill.
- Install the 4 drop-in stainless-steel anchors supplied and set with the proper tool. (Not provided)
- Using a #2 square head screwdriver, install the grate and tighten the brass screws supplied to 30 in/lbs torque:
MLD-FGD-1818 - (4) 1/4"X20X1-1/4" (Mo# BOLT-03BS)
- Use the fasteners provided to insure a minimum of 3 complete turns into concrete anchor. Ensure screws heads are flush.
- Total head loss at maximum flow rate is less than 0.3 PSI.



VGB-2008

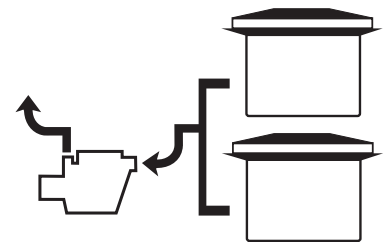
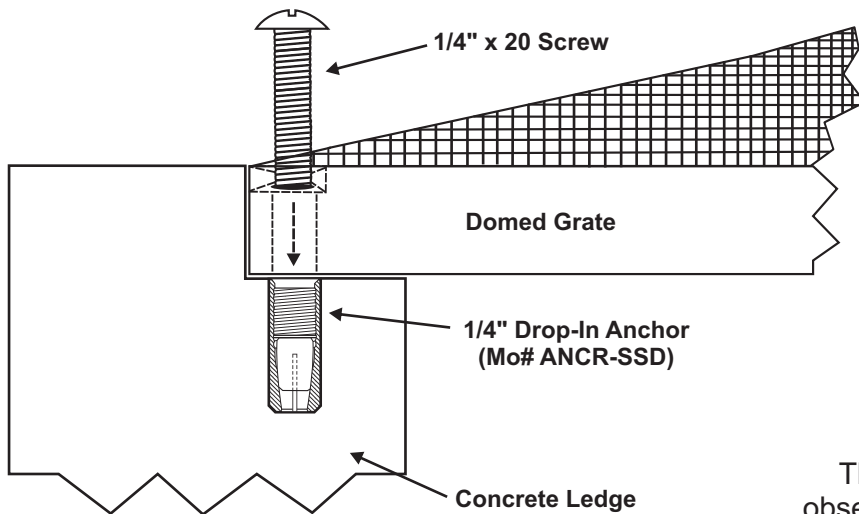

CAUTION:

The suction fitting fasteners must be observed for damage or tampering before each use of this facility and or at least annually.

Link to general certification of conformity to VGB 2008
<http://www.lawsonaquatics.com/certification.htm>

LAWSON AQUATICS™
The Wizards of Aquatic Technology

Doc. # 2010 Replacement Domed Grate 1818 Rev. 07-09

Call 1.800.897.6160
for inquiries or assistance

Visit us at: www.lawsonaquatics.com



WARNING / ATTENTION / AVISO

MAIN DRAIN INSTALLATION INSTRUCTIONS

FOR FIELD BUILT SUMPS FOR ALL SIZES OF FRAMES & GRATES FOR SUBMERGED SUCTION OUTLETS

Flow rates are NOT NSF certified for field-fabricated sumps, and must be approved as a complete system by registered design professional.

- 1 Read all general, safety and installation literature first and then keep them for future reference. If there are any questions or further information needed call 1-800-897-6160 for assistance.
- 2 Frame have inserts for insertion of fasteners.
- 3 Place the frame over the concrete formed pit. Drill hole for receipt of protruding inserts when supplied
- 4 Insert and tighten the stainless steel square head screw in place to secure grate to the frame. Use only the fasteners supplied. Refer to Document #2020 for installation instructions.
- 5 It is suggested to place a board over the opening until the pool has been surfaced and ready to receive the grate.

6 MAXIMUM FLOW RATES AS TESTED ON MANUFACTURER'S SUMPS.

Maximum rated flow rates	Acceptable pipe size	Tested pipe depth
18X36 - Floor: 2,080GPM; Wall: 1,496GPM	10" or larger	1 to 1 ratio
18x18 - Floor: 816 GPM; Wall: 712 GPM	8" or larger	1 to 1 ratio
12x12 - Floor: 365 GPM; Wall: 340 GPM	6" or larger	1 to 1 ratio
9x9 - Floor: 261 GPM; Wall: 248 GPM	4" or larger	1.5 to 1 ratio

- 7 For 18"x36", 18"x18" and 12"x12" flow rates were tested on a sump with a distance from the underside of the grate to the top of the pipe equal to the inside diameter of the pipe. The acceptable pipe sizes shown above are the minimum size to be used. **For smaller size piping and the 9"x9", the sump must be built to the minimum dimensions shown in the diagram below.**



VGB-2008

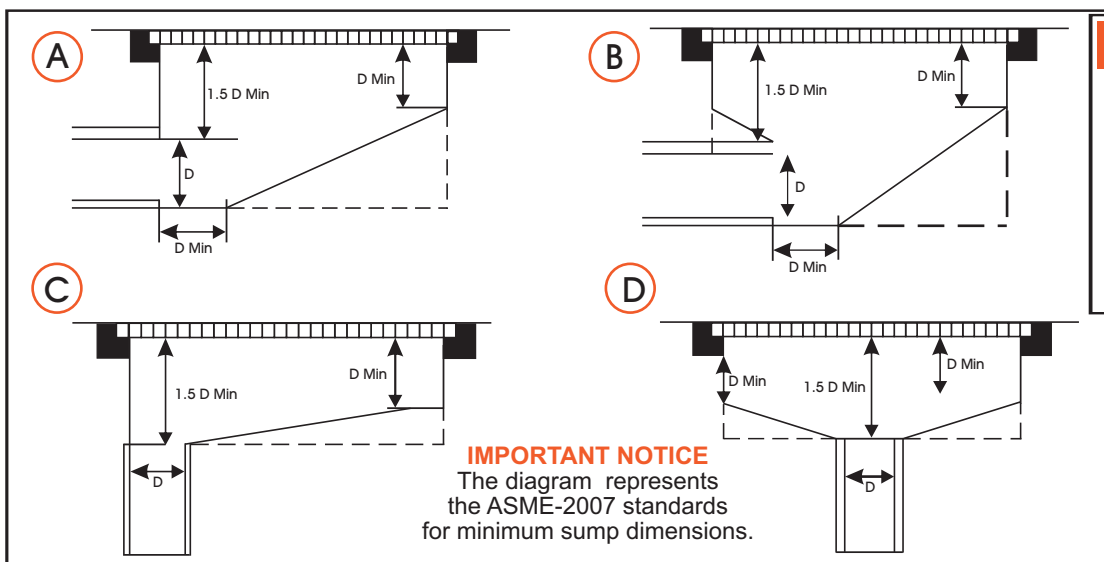
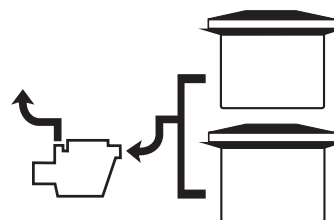

NOTE

- 1 D = Inside diameter of pipe.
- 2 All dimensions shown are minimums.
- 3 A broken line indicates suggested sump configuration.

CAUTION: The suction fitting fasteners must be observed for damage or tampering before each use of this facility and/or at least annually.

Link to general certification of conformity to VGB 2008
<http://www.lawsonaquatics.com/certification.htm>



Call 1.800.897.6160
for inquiries or assistance

Visit us at: www.lawsonaquatics.com