

# Installation and Maintenance

All Bowman swimming pool heat exchangers must be installed in accordance with the 'Installation, Operation & Maintenance Guide' which can be downloaded from our website - [www.bowman-pool-heat-exchangers.com](http://www.bowman-pool-heat-exchangers.com)

Pool Water Flow - The maximum pool water flow rates detailed in the ratings charts must not be exceeded.

Operating Temperature - Heating water must not exceed 248° F.

Operating Pressure - The maximum working pressure on both sides is 3bar (43.5psi).

Mounting - The heat exchanger can be mounted vertically or horizontally as per the diagram below.

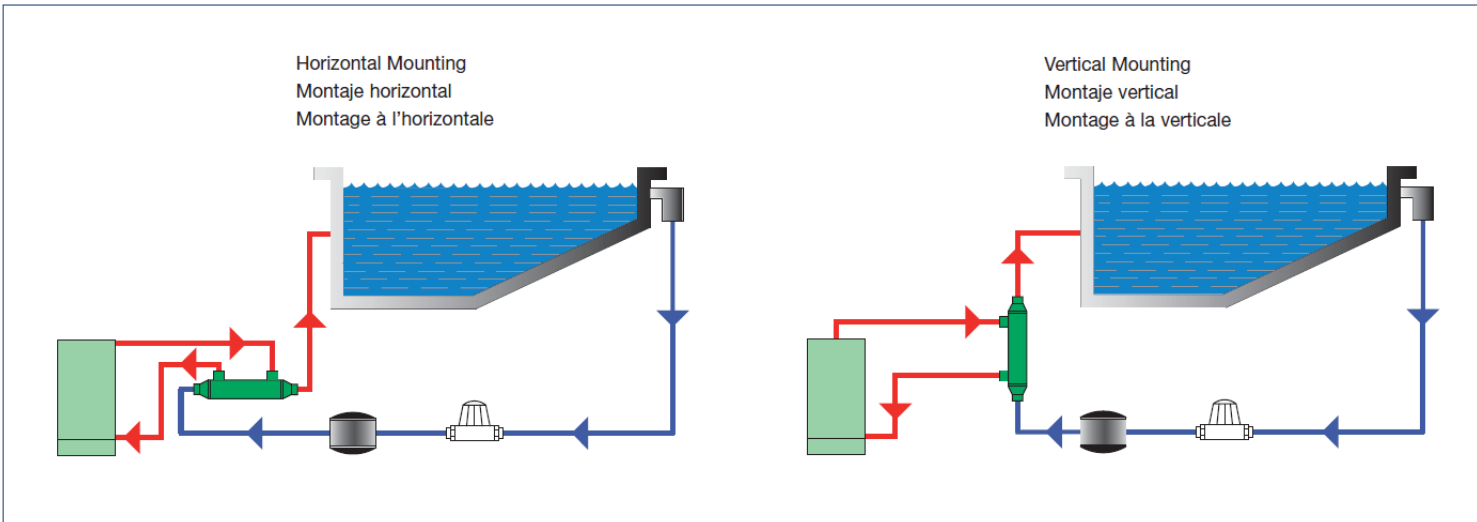

## Warranty

CN Series Heat Exchangers are warranted to be free from defects in materials and workmanship in manufacturing for a period of twelve months from the original date of purchase or eighteen months from the original date of invoice to sales dealer. CN Series will be repaired or replaced as options without charge,

upon return prepaid to supplier, if it is found to be defective during the warranty period specified with a valid warranty claim and upon inspection by supplier. All warranty claims will be handled in accordance with terms of warranty provided at the time of sale.

**Stocking Distributors for North America**

**Call Toll Free 1-877-751-9414**

70 Esna Park Drive, Unit 3  
Markham, ON L3R 6E7  
Tel: 905-940-0961  
Fax: 905-940-0983



Email: [info@valutechinc.com](mailto:info@valutechinc.com)

[www.valutechinc.com](http://www.valutechinc.com)

## Bowman® Pool Heat Exchangers

Serving the thermal and process industry for over twenty years - Valutech Inc is a highly reputed and well established company supplying heat exchangers to home builders, pool builders, pool designers and plumbing contractors.

Valutech Inc. is a stocking distributor for Bowman in North America.

Homeowners, building managements, hotels, YMCA's, municipalities, community centers, school districts, and commercial scale pools rely on Valutech Inc. to provide heat exchanger sizing recommendations for their pools. We provide custom designed pool heat exchanger solutions from the simplest pools and spas to the most complex commercial and wave pool requirements.

Bowman indirect heat exchangers provide a cost effective and energy efficient means of heating swimming pools as compared to the use of conventional direct fired pool heaters.

Unlike direct fired pool heaters, which are tied to either gas or propane lines, our heat exchangers utilize hot water from a boiler to "indirectly" heat swimming pool water. The resulting efficiency of these systems is very high as we are able to take advantage of the high efficiency of the boiler. Modern hot water boilers offer efficiencies well over 80% and in some cases efficiencies are greater than 95%.

- High Efficiency
- Compact Design
- Heavy Duty Construction
- Removable Tubestacks for Easy Cleaning
- Manufactured under ISO 9001-2008

Bowman models are available in the following ranges:

CN-P and Ti Models for use with boilers  
CN-XL Models for large and commercial pools for use with boilers  
CN-S models for use with Solar Panels, Geothermal Systems and Heat Pumps

**All units in stock and available for immediate delivery**



CN Series	2
CN Solar and Geothermal	2
CN-XL Series	4
CN Specifications and sizing	7

# CN Series Heat Exchangers

Indirect pool heating is becoming increasingly popular and is growing with alternative heating applications such as hydronic heating, solar thermal, geothermal and biomass heating. These alternative methods of transferring heat are energy efficient and are expected to grow in popularity due to rising energy prices.

The CN Series are available in capacities ranging from 135,000 Btu/hr to 400,000 Btu/hr.

## CN P and Ti Heat Exchangers for Boilers

The CN P and Ti Series heat exchangers have Cupro Nickel Titanium or Stainless Steel tubes encased in cast steel with composite end covers that have solvent weld connections that fit directly into pool pipework. Cupro Nickel and Titanium are widely used for marine applications and are ideal for salt water pools and spas. These units can also be used for cooling pools in warmer climates.



Shown: CN400P 400,000 btu/hr

## CN S for Solar, Geothermal and Heat Pumps



The CN S Series heat exchangers have Cupro Nickel Titanium or Stainless Steel tubes encased in cast steel with composite end covers that have solvent weld connections that fit directly into pool pipework. These series are made specifically for Solar, Geothermal and Heat Pump applications and are ideal for salt water pools and spas.

**Applications**  
Pools, Spas, and hot tubs  
Domestic hot water  
Sea water applications  
Waste water heat recovery  
Freshwater Aquaculture  
Aquaponics

**Standard Material**  
Tube side (Pool Water): Cupro Nickel/Titanium  
Shell Side (Boiler Water) Cast Iron

**Maximum Pressure**  
Hot Side: 6 barg (87psig)  
Cold Side: 6 barg (87psig)

**Maximum Temperature**  
100 Deg. C



# Instructions for Use

1. Always keep pH to recommended levels. The ideal salt water pool pH for Cupro-Nickel heat exchangers should be kept to within 7.4 to 7.6. Check regularly to ensure these levels are maintained. Alter pool conditions if necessary (see Table 1 on the next page - not applicable to Bowman Titanium Heat Exchangers).
2. Ensure chlorine/salt levels are within the range recommended by the chemical manufacturer and are in accordance with the type of pool, for e.g. private, hotel, school or municipal.
3. If a bypass is fitted to the heat exchanger circuit, it is essential that any valves are correctly positioned to allow the recommended pool water flow to pass through the heat exchanger pump, etc.
4. Keep pool free from debris such as leaves, grass cuttings etc. This foreign matter can decay and increase the pH level in the pool.
5. The filter unit should be checked regularly especially sand filters. This type if working incorrectly, can allow sand to pass around the pool circuit causing erosion of the pipe work, heat exchanger.
6. For chlorine pools it is essential that the correct amount of chlorine is added to the pool. To allow for proper dispersion of the dose, distribute the chemicals to various areas of the pool. Do not dose in one area only, as this will create high acid areas which can cause corrosion/erosion of the pool equipment. It is also important that the heat exchanger is installed upstream of the chlorinator.
7. It is required that the heat exchanger be grounded along with all metal components of the system. This can be done by firmly connecting a copper cable to the mounting bracket.

Model	Pool Volume Gallons	Boiler Flow GPM	Pool Flow GPM	Heat Load (BTU)		
				180F	140F	
<b>For use with Boilers</b>						
CN135	11,000	10.5	45	135,000	75,000	
CN200	20,000	15.8	66	240,000	135,000	
CN400	40,000	23.8	93	340,000	190,000	
CN650	60,000	31.7	127	545,000	310,000	
CN1000	100,000	54.5	222	1,000,000	825,000	
CN1500	156,000	84.5	330	1,900,000	1,050,000	
CN2000	240,000	126	500	2,650,000	1,500,000	
<b>For use with Solar Panels and Heat Pumps</b>						
				158F	140F	113F
CNS135	13,500	5.28	27	82,000	61,000	30,000
CNS200	32,000	13.2	66	24,000	175,000	85,000
CNS400	44,000	19.8	100	420,000	310,000	150,000
CNS650	60,000	25.1	127	600,000	440,000	220,000



Manufactured under ISO 9001-2008 Quality Guidelines

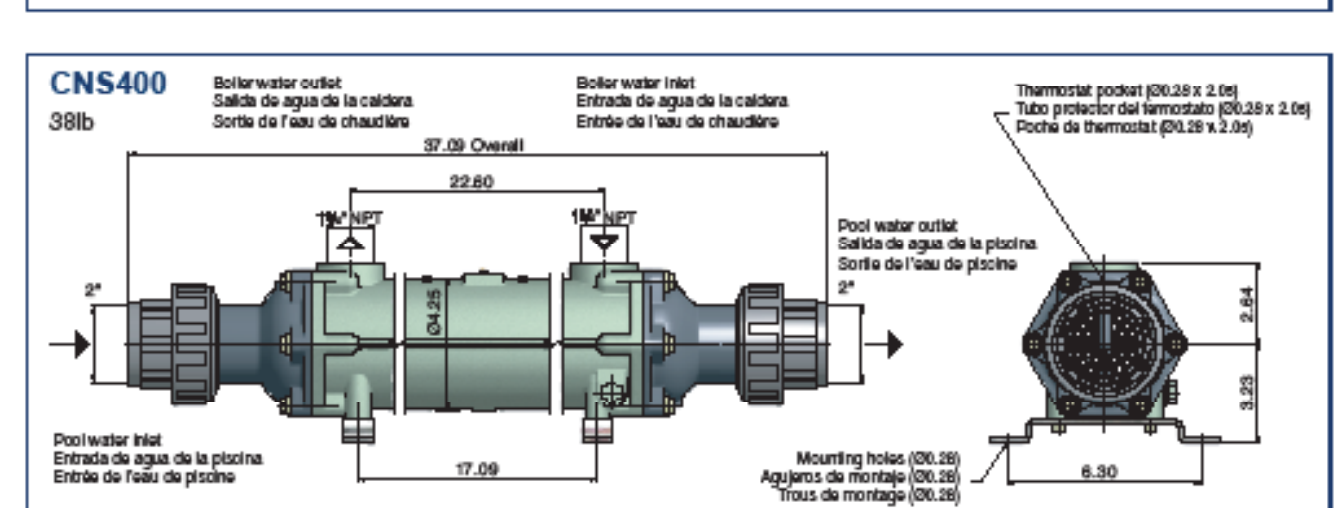
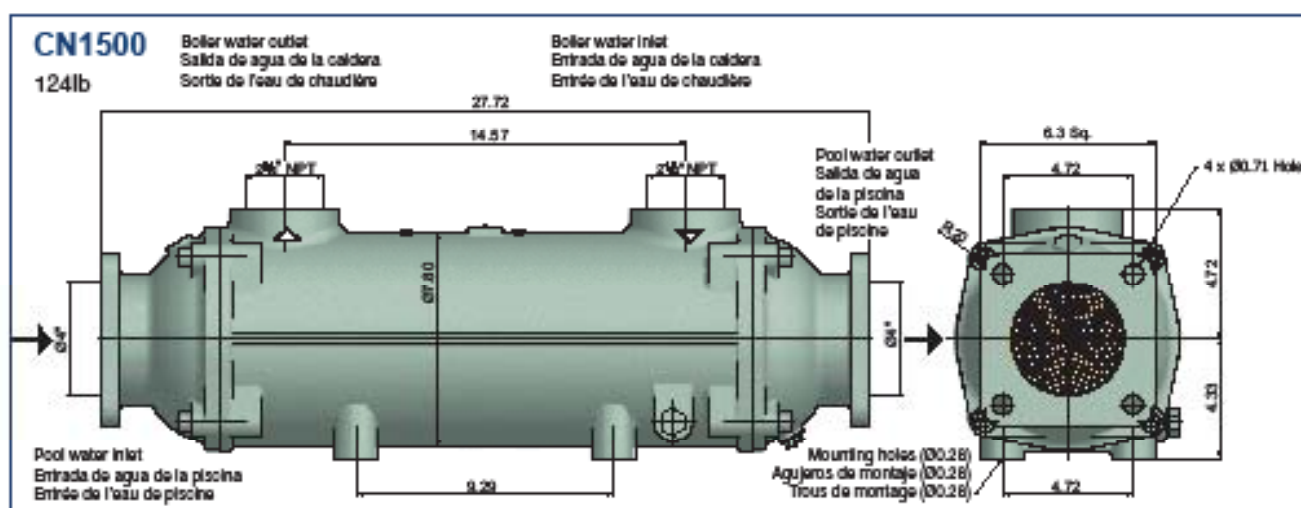
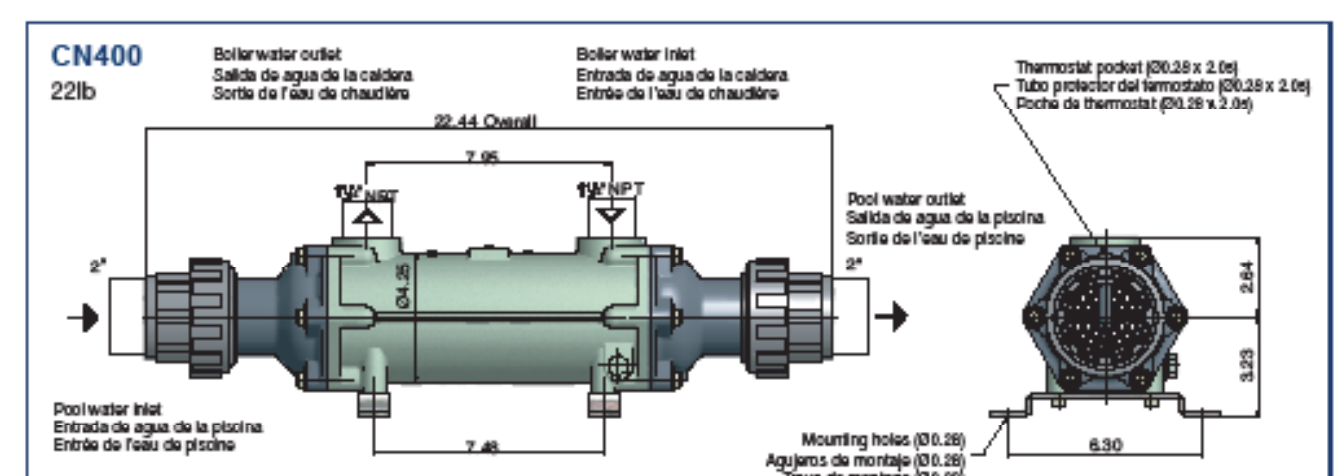
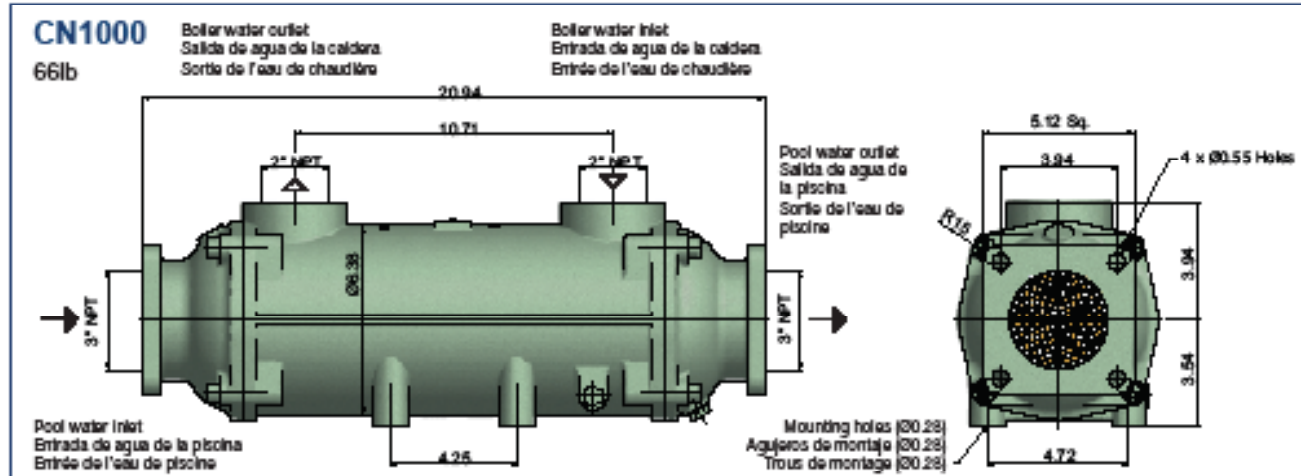
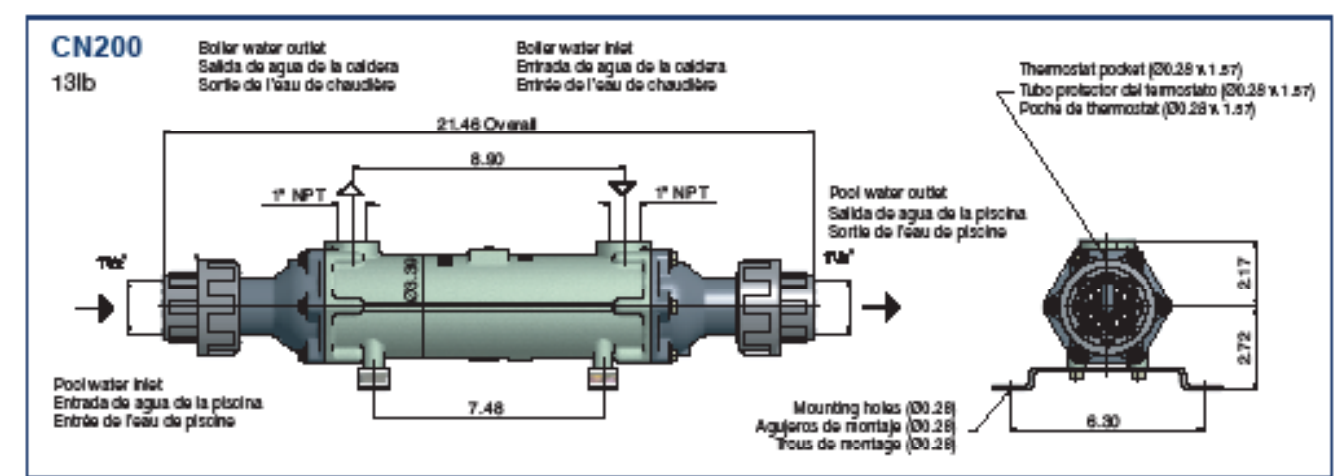
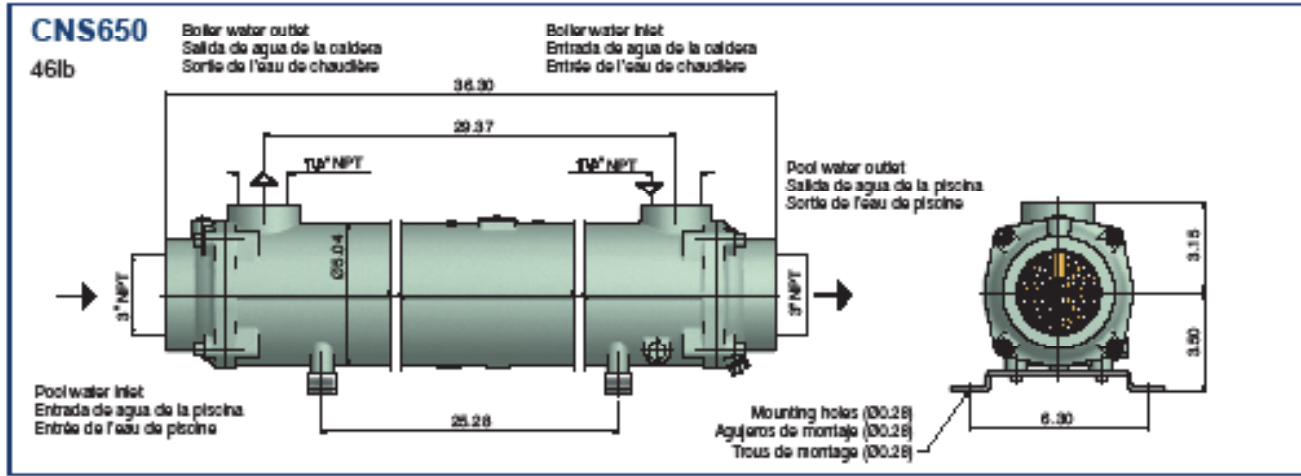
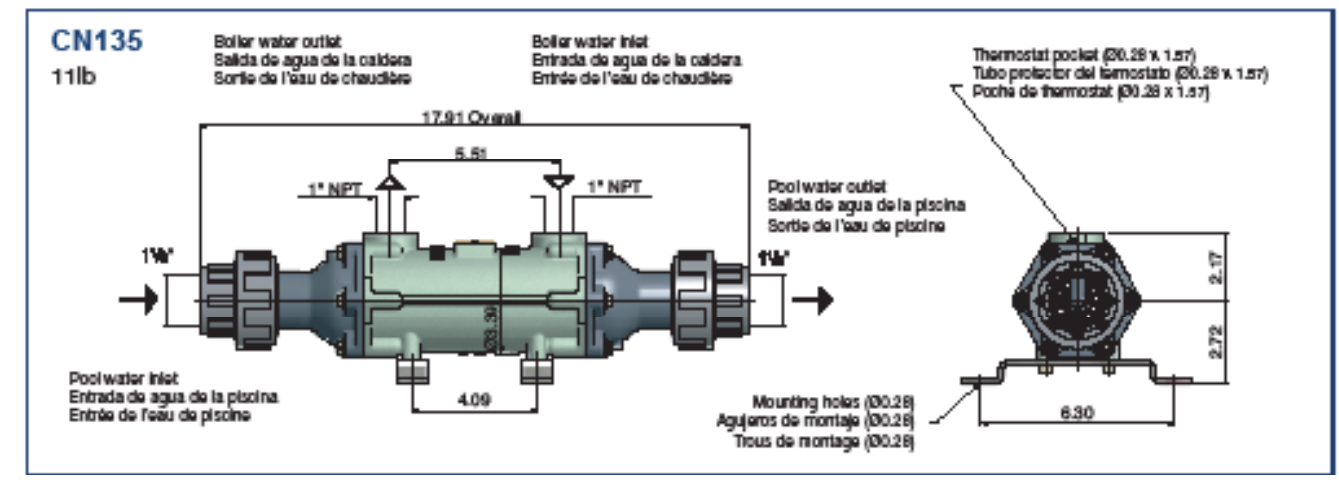
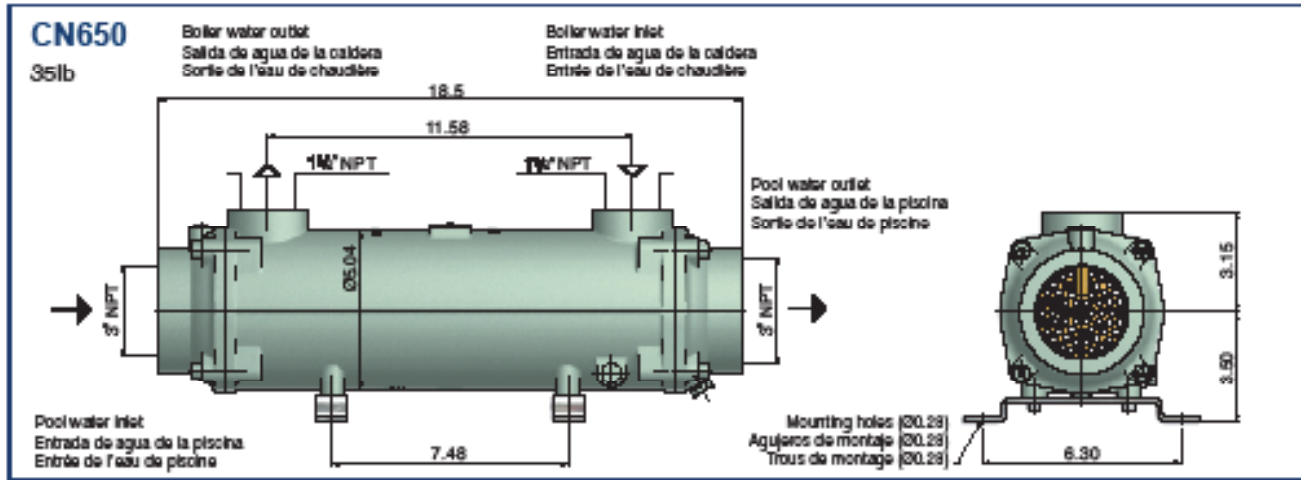

# CN-XL Commercial Grade Heat Exchangers

## Recreation/Resort Pools/ Municipal Pools:

The CN-XL series of heat exchangers are ideal for large commercial applications such as water parks, YMCA's and Olympic pools found in municipal arenas, colleges and universities. The CN-XL range starts with our model CN650 which is capable of heating a 75,000 gallon pool by 1 F per hour. The range extends to our model CN2000 which is capable of heating a 235,000 gallon pool. Due to the large volumes of such pools very large water flow rates are required to circulate for filtration and heating. The CN2000 is able to handle a pool water flow rate of 1100 gallons per minute with a head loss of only 10 feet H2O.

## Geothermal:

Indirect pool heat exchangers have typically utilized conventional boilers as their source of heat. In recent years increased energy prices coupled with greater environmental awareness has resulted in the growth of alternative sources of energy such as geothermal heating. Geothermal heat pumps provide warm water in the 100F to 120F range which is not hot enough for effective heat transfer in most heat exchangers. Bowman CN-XL series unique design coupled with large surface areas provide effective heat transfer while handling very large pool water flow rates with minimal head loss.

## Cooling Applications for Pools in Warm Climates:

Swimming pools offer the most enjoyment to swimmers when the temperature is in the 80F – 90F temperature range. While pool heating is a concern in most temperate regions pool cooling is of greater importance in tropical and warm temperate regions in summer. Many CN –XL series units are installed in conjunction with chillers in residential and commercial installations in warmer regions. The temperature differentials involved in cooling are typically smaller than with most heating applications so it is important to size the heat exchangers properly to ensure they are capable of fully utilizing the capacity of the chiller. Please contact us for sizing inquiries.

## Hospitals/Therapy Pools:

Many patients suffering from cardiovascular, neurological and musculoskeletal disorders find movement difficult and painful. Therapy pools provide an excellent medium for physical therapy and are kept at relatively warm temperatures to ensure comfort for the patient. They typically operate in the 90F to 95F temperature range which is intermediate between pools and spas and it is important that the heat exchanger is sized correctly to ensure the pool operates at the desired temperature. In addition therapy pools have a high percentage of make-up water which must be heated from city water temp to the 90-95F range and this must be considered when sizing.



## CN-XL MODELS

- CN650
- CN1000
- CN1500
- CN2000

