

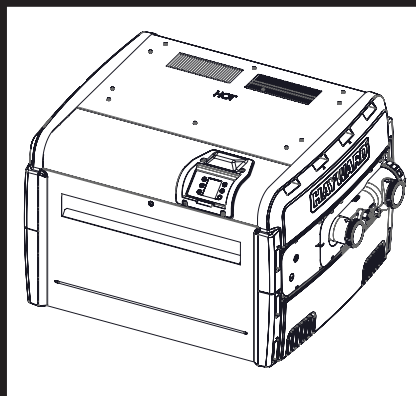

In-Ground Pool/Spa Gas Heaters

Owner's Manual



Contents

- Safety Instructions.....1
- Getting Started.....6
- Specifications.....7
- Installation.....11
- Electrical Connections.....23
- Configuration and Operation.....25
- Maintenance and Service.....32
- Troubleshooting.....40
- Service Parts.....44
- Warranty.....46







- | | | | |
|---------|-----------|-------------|----------|
| HS135FD | W3HS135FD | HS250FDASME | SWS135DH |
| HS150FD | W3HS150FD | HS400FDASME | SWS150DH |
| HS200FD | W3HS200FD | HS500FDASME | SWS200DH |
| HS250FD | W3HS250FD | | SWS250DH |
| HS400FD | W3HS400FD | | |
| HS500FD | | | |

Hayward Industries
 1415 Vantage Park Dr., Suite 400
 Charlotte, NC 28203
 Phone (908)-355-7995
www.hayward.com



IMPORTANT SAFETY INSTRUCTIONS

Basic safety precautions should always be followed, including the following: Failure to follow instructions can cause severe injury and/or death.

-  This is the safety-alert symbol. When you see this symbol on your equipment or in this manual, look for one of the following signal words and be alert to the potential for personal injury.
-  **WARNING** – Warns about hazards that could cause serious personal injury, death or major property damage and if ignored presents a potential hazard.
-  **CAUTION** – Warns about hazards that will or can cause minor or moderate personal injury and/or property damage and if ignored presents a potential hazard. It can also make consumers aware of actions that are unpredictable and unsafe.
-  **ATTENTION** – Indicates special instructions that are important but not related to hazards.

 **WARNING** – Read and follow all instructions in this owner’s manual and on the equipment. Failure to follow instructions can cause severe injury and/or death.

 **WARNING** – If the information in these instructions is not followed exactly, a fire or explosion may result causing property damage, injury, or death.
Do not store or use gasoline or other flammable vapors or liquids in the vicinity of this or any other appliance.

WHAT TO DO IF YOU SMELL GAS:

- Do not try to light any appliance.
- Do not touch any electrical switch; do not use any phone in your building.
- Immediately call your gas supplier from a neighbor’s phone. Follow the gas supplier’s instructions. If you cannot reach your gas supplier, call the fire department.
- Installation and service must be performed by a qualified installer, service agency, or the gas supplier.

 **WARNING** – This product must be installed and serviced by authorized personnel, qualified in pool/spa heater installation. Improper installation and/or operation can create carbon monoxide gas and flue gases that can cause serious injury, property damage, or death.

USE OF NON-HAYWARD REPLACEMENT PARTS VOIDS WARRANTY.





 **WARNING** – Pool heaters are heat producing appliances. To avoid possible over heating of the outer jacket and damage or injury with such an event: (1) no materials should be stored against the jacket and (2) care should be taken to avoid unnecessary contact (especially by children) with the jacket.

 **WARNING** – When lighting a gas heater, the lighting instructions must be followed exactly to prevent “flashback” of excess gas in the heater. Electronic ignition heaters and electric heaters must have the power shut off when making adjustments for servicing, or coming into contact with the heater.

 **WARNING** – UNDER NO CIRCUMSTANCES SHOULD FLAMMABLE MATERIALS, SUCH AS GASOLINE OR PAINT THINNERS, BE USED OR STORED IN THE VICINITY OF THE HEATER OR IN ANY LOCATION FROM WHICH FUMES COULD REACH THE HEATER.

See product plate for manufacturer’s information.
For warranty information, please go to www.hayward.com/warranty.

 **WARNING** – **Suction Entrapment Hazard.** Suction in suction outlets and/or suction outlet covers, which are damaged, broken, cracked, missing, or unsecured cause severe injury and/or death due to the following entrapment hazards:

-  **Hair Entrapment** – Hair can become entangled in suction outlet cover.
-  **Limb Entrapment** – A limb inserted into an opening of a suction outlet sump or suction outlet cover that is damaged, broken, cracked, missing, or not securely attached can result in a mechanical bind or swelling of the limb.
-  **Body Suction Entrapment** – A differential pressure applied to a large portion of the body or limbs can result in an entrapment.
-  **Evisceration/ Disembowelment** – A negative pressure applied directly to the intestines through an unprotected suction outlet sump or suction outlet cover which is damaged, broken, cracked, missing, or unsecured can result in evisceration/disembowelment.
-  **Mechanical Entrapment** – There is potential for jewelry, swimsuits, hair decorations, fingers, toes, or knuckles to be caught in an opening of a suction outlet cover resulting in mechanical entrapment.

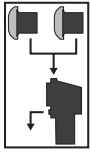

▲WARNING – To Reduce the risk of Entrapment Hazards:

- When outlets are small enough to be blocked by a person, a minimum of two functioning suction outlets per pump must be installed. Suction outlets in the same plane (i.e. floor or wall), must be installed a minimum of three feet (3') [0.91 meter] apart, as measured from near point to near point.
- Dual suction fittings shall be placed in such locations and distances to avoid “dual blockage” by a user.
- Dual suction fittings shall not be located on seating areas or on the backrest for such seating areas.
- The maximum system flow rate shall not exceed the flow rating as listed in Table 1: Specifications.
- Never use pool or spa if any suction outlet component is damaged, broken, cracked, missing, or not securely attached.
- Replace damaged, broken, cracked, missing, or not securely attached suction outlet components immediately.
- Install two or more suction outlets per pump in accordance with latest ASME, APSP Standards and CPSC guidelines. Follow all applicable National, State, and Local codes.
- Installation of a vacuum release or vent system, which relieves entrapping suction, is recommended.

▲WARNING – Failure to remove pressure test plugs and/or plugs used in winterization of the pool/spa from the suction outlets can result in an increase potential for suction entrapment as described above.

▲WARNING – Failure to keep suction outlet components clear of debris, such as leaves, dirt, hair, paper and other material can result in an increase potential for suction entrapment as described above.

▲WARNING – Suction outlet components have a finite life, the cover/grate should be inspected frequently and replaced at least every ten years or if found to be damaged, broken, cracked, missing, or not securely attached.

▲CAUTION – Components such as the filtration system, pumps and heater must be positioned so as to prevent their being used as means of access to the pool by young children. To reduce risk of injury, do not permit children to use or climb on this product. Closely supervise children at all times. Components such as the filtration system, pumps, and heaters must be positioned to prevent children from using them as a means of access to the pool.



▲WARNING – **Hazardous Pressure.** Pool and spa water heating and circulation systems operate under hazardous pressure during start up, normal operation, and after pump shut off. Stand clear of circulation system equipment during pump start up. Failure to follow safety and operation instructions could result in violent separation of the pump housing and cover, and/or filter housing and clamp due to pressure in the system, which could cause death, severe personal injury and/or property damage. Before servicing pool and spa water circulation system, all system and pump controls must be in off position and filter manual air relief valve must be in open position. Before starting system pump, all system valves must be set in a position to allow system water to return back to the pool. Do not change filter control valve position while system pump is running. Before starting system pump, fully open filter manual air relief valve. Do not close filter manual air relief valve until a steady stream of water (not air or air and water) is discharged.



▲WARNING – **Separation Hazard.** Failure to follow safety and operation instructions could result in violent separation of pump components. Strainer cover must be properly secured to pump housing with strainer cover lock ring. Before servicing pool and spa circulation system, all system and pump controls must be in off position and filter manual air relief valve must be in open position. Do not operate pool and spa circulation system if a system component is not assembled properly, damaged, or missing. Do not operate pool and spa circulation system unless filter manual air relief valve body is in locked position in filter upper body. **Never operate or test the circulation system at more than 50 PSI. Do not purge the system with compressed air.** Purging the system with compressed air can cause components to explode, with risk of severe injury or death to anyone nearby. Use only a low pressure (below 5 PSI), high volume blower when air purging the pump, filter, or piping.



▲WARNING – **Risk of Electric Shock.** All electrical wiring **MUST** be in conformance with applicable local codes, regulations, and the National Electric Code (NEC). Hazardous voltage can shock, burn, and cause death or serious property damage. To reduce the risk of electric shock, do NOT use an extension cord to connect unit to electric supply. Provide a properly located electrical receptacle. Before working on pump or motor, turn off power supply to the pump.

▲WARNING – To reduce the risk of electric shock replace damaged wiring immediately. Locate conduit to prevent abuse from lawn mowers, hedge trimmers and other equipment. Do NOT ground to a gas supply line.



▲WARNING – **Risk of Electric Shock.** Failure to ground all electrical equipment can cause serious or fatal electrical shock hazard. Electrically ground all electrical equipment before connecting to electrical power supply.



▲WARNING – **Risk of Electric Shock.** Failure to bond all electrical equipment to pool structure will increase risk for electrocution and could result in injury or death. To reduce the risk of electric shock, see installation instructions and consult a professional electrician on how to bond all electrical equipment. Also, contact a licensed electrician for information on local electrical codes for bonding requirements.



Notes to electrician: Use a solid copper conductor, size 8 or larger. Run a continuous wire from external bonding lug to reinforcing rod or mesh. Connect a No. 8 AWG (8.4 mm²) [No. 6 AWG (13.3 mm²) for Canada] solid copper bonding wire to the pressure wire connector provided on the electrical equipment and to all metal parts of swimming pool, spa, or hot tub, and metal piping (except gas piping), and conduit within 5 ft. (1.5 m) of inside walls of swimming pool, spa, or hot tub. **IMPORTANT** - Reference NEC codes for all wiring standards including, but not limited to, grounding, bonding and other general wiring procedures. **Additionally, Hayward recommends the use of a sacrificial anode(s). Sacrificial anodes provide protection to the heat exchanger against galvanic corrosion when properly installed. Sacrificial anodes should be regularly inspected and replaced before the end of their useful life.**

⚠WARNING – Risk of Electric Shock. The electrical equipment must be connected only to a supply circuit that is protected by a ground-fault circuit-interrupter (GFCI). Such a GFCI should be provided by the installer and should be tested on a routine basis. To test the GFCI, push the test button. The GFCI should interrupt power. Push reset button. Power should be restored. If the GFCI fails to operate in this manner, the GFCI is defective. If the GFCI interrupts power to the electrical equipment without the test button being pushed, a ground current is flowing, indicating the possibility of an electrical shock. Do not use this electrical equipment. Disconnect the electrical equipment and have the problem corrected by a qualified service representative before using.

⚠CAUTION – These heaters are intended for use with permanently-installed pools and may be used with hot tubs and spas if so marked. Do not use with storable pools. A permanently-installed pool is constructed in or on the ground or in a building such that it cannot be readily disassembled for storage. A storable pool is constructed so that it is capable of being readily disassembled for storage and reassembled to its original integrity.

⚠WARNING – Risk of Hyperthermia. To avoid hyperthermia the following “Safety Rules for Hot Tubs” are recommended by the U.S. Consumer Product Safety Commission.

1. Spa or hot tub water temperatures should never exceed 104°F [40°C]. A temperature of 100°F [38°C] is considered safe for a healthy adult. Special caution is suggested for young children. Prolonged immersion in hot water can induce hyperthermia.
2. Drinking of alcoholic beverages before or during spa or hot tub use can cause drowsiness, which could lead to unconsciousness and subsequently result in drowning.
3. Pregnant women beware! Soaking in water above 100°F [38°C] can cause fetal damage during the first three months of pregnancy (resulting in the birth of a brain-damaged or deformed child). Pregnant women should adhere to the 100°F [38°C] maximum rule.
4. Before entering the spa or hot tub, users should check the water temperature with an accurate thermometer; spa or hot tub thermostats may err in regulating water temperatures by as much as 4°F (2.2°C).
5. Persons taking medications, which induce drowsiness, such as tranquilizers, antihistamines or anticoagulants, should not use spas or hot tubs.
6. If the pool/spa is used for therapy, it should be done with the advice of a physician. Always stir pool/ spa water before entering the pool/spa to mix in any hot surface layer of water that might exceed healthful temperature limits and cause injury. Do not tamper with controls because scalding can result if safety controls are not in proper working order.
7. Persons with a medical history of heart disease, circulatory problems, diabetes or blood pressure problems should obtain a physician's advice before using spas or hot tubs.
8. Hyperthermia occurs when the internal temperature of the body reaches a level several degrees above normal body temperature of 98.6°F [37°C]. The symptoms of Hyperthermia include: drowsiness, lethargy, dizziness, fainting, and an increase in the internal temperature of the body.

The effects of Hyperthermia include:

- Unawareness of impending danger.
- Failure to perceive heat.
- Failure to recognize the need to leave the spa.
- Physical inability to exit the spa.
- Fetal damage in pregnant women.
- Unconsciousness resulting in danger of drowning.

SAVE THESE INSTRUCTIONS

Definitions:

- ANSI:** American Nation Standards Institute
CSA: Canadian Standards Association
CGA: Canadian Gas Association
NFPA: National Fire Protection Association
NEC: National Electric Code
SCAQMD: South Coast Air Quality Management District
ISTA: International Safe Transit Association
Suction Outlet: The Suction Outlet is a fitting, fitting assembly, cover/grate and related components that provide a means for water to exit the pool and return into the pump circulating system. This fitting may also be referred to as the “Main Drain”



Bypass Valves: A valve or series of valves that direct the pool water to flow or not flow through the heater.

Pressure measurement units:

Inches of Mercury (inHg) is typically used with atmospheric pressure measurements.

Pounds per square inch (PSI) is typically used with water “pressure”, “suction” or system measurements.

Inches of Water (inwc) is typically used with gas or air pressure measurements (1.0 inHg = .49 PSI = 13.5inwc)

Certification and Compliance		
Certification Codes and Standards	USA	Canada
Design Certified	ETL	ETL
Design Compliant	ANSI Z21.56	CSA 4.7
Installation Compliant Gas	NFPA 54, ANSI Z223.1, NFPA 58	CAN/CSAB149.1-2
Installation Compliant Electric	ANSI/NFPA 70, NEC	CSA C22.1 - Canadian Electrical Code, Part 1
Emissions	SCAQMD 1146.2	
Shipping Compliant	ISTA 3B	ISTA 3B

CONFORMANCE WITH CODES: The heater shall be installed in accordance with all local and state codes and with the requirements of the authority having jurisdiction of the installing site. The heater installation must conform to the latest edition of the above listed installation codes.

⚠ WARNING	
<ul style="list-style-type: none"> • INGESTION HAZARD: This product contains a button cell or coin battery. • DEATH or serious injury can occur if ingested. • A swallowed button cell or coin battery can cause Internal Chemical Burns in as little as 2 hours. • KEEP new and used batteries OUT OF REACH or CHILDREN. • Seek immediate medical attention if a battery is suspected to be swallowed or inserted inside any part of the body. 	

⚠ WARNING – Even used batteries may cause death or serious injury.

⚠ WARNING – Call a local poison control center for treatment information.

⚠ WARNING – Remove and immediately recycle or dispose of used batteries according to local regulations and keep away from children. Do NOT dispose of batteries in household trash or incinerate.

⚠ WARNING – This product contains non-rechargeable batteries. Do NOT force discharge, recharge, disassemble, heat above 85°C, or incinerate. Doing so may result in injury due to venting, leakage, or explosion resulting in chemical burns.

⚠ WARNING – This product contains non-replaceable batteries. Do NOT under any circumstances attempt to remove or replace the factory-installed battery.

⚠ WARNING – Non-rechargeable batteries are not to be recharged.

⚠ NOTICE – This product contains a Panasonic BR2032 coin-type lithium battery.

⚠ NOTICE – The nominal voltage of the battery contained within this product is 3V.



Certificate of Conformity

Product: Universal H-Series and Universal HC Series Gas Heaters
CPSC Regulation: Safety Standard for Button Cell or Coin Batteries and Consumer Products Containing Such Batteries
Underwriters Laboratories UL 4200A-2023
Manufacturer: Hayward Industries
1415 Vantage Park Drive, Suite 400, Charlotte, NC 28203
Technical Service Phone: (908) 355-7995
Manufacture Location: Hayward Industries, 2935 Sidco Drive, Nashville, TN 37204
Date Manufactured: The serial number is a 17 digit number
Example serial number: 211323051*****001
The 5th - 8th digits are the "year and month" of the date of manufacture
Example above is the 5th month of 2023
Tested By: Hayward Industries, One Industrial Drive, Clemmons, NC 27012
Phone: (908) 355-7995
Test Report: July 2025

I hereby certify that the finished product(s) covered by this certificate comply with the rules, bans, standards, and regulations stated herein, and that the information in this certificate is true and accurate to the best of my knowledge, information, and belief. I understand and acknowledge that it is a United States federal crime to knowingly and willfully make any materially false, fictitious, or fraudulent statement, representation, or omission on this certificate.

Supplier's Declaration of Conformity

47 CFR § 2.1077 Compliance Information

Unique Identifier: Universal H-Series and Universal HC Series Gas Heaters
FCC Responsible Party: Hayward Industries, Inc.
One Hayward Industrial Drive Clemmons, NC 27012 www.hayward.com

Contains FCC ID: RNW-BT923

Contains IC ID: 5110A-BT923

In order to avoid the possibility of exceeding the FCC radio frequency exposure limits, human proximity to the antenna should not be less than 20cm during operation.

This device complies with part 15 of the FCC Rules. Operation is subject to the following two conditions: (1) This device may not cause harmful interference, and (2) this device must accept any interference received, including interference that may cause undesired operation.

Changes or modifications not expressly approved by Hayward could void the user's authority to operate this equipment.

NOTE: This equipment has been tested and found to comply with the limits for a Class B digital device, pursuant to Part 15 of the FCC Rules. These limits are designed to provide reasonable protection against harmful interference in a residential installation. This equipment generates, uses and can radiate radio frequency energy and, if not installed and used in accordance with the instructions, may cause harmful interference to radio communications. However, there is no guarantee that interference will not occur in a particular installation. If this equipment does cause harmful interference to radio or television reception, which can be determined by turning the equipment off and on, the user is encouraged to try to correct the interference by one or more of the following measures:

- Reorient or relocate the receiving antenna.
- Increase the separation between the equipment and receiver.
- Connect the equipment into an outlet on a circuit different from that to which the receiver is connected.
- Consult the dealer or an experienced radio / TV technician for help.

This Class B digital apparatus complies with Canadian ICES-003.
Cet appareil numérique de la classe B est conforme à la norme NMB-003 du Canada.

This device complies with Industry Canada license exempt RSS standard(s). Operation is subject to the following two conditions: (1) This device may not cause interference, and
(2) This device must accept any interference, including interference that may cause undesired operation of the device.

Le présent appareil est conforme aux CNR d'Industrie Canada applicables aux appareils radio exempts de licence. L'exploitation est autorisée aux deux conditions suivantes:

- (1) l'appareil ne doit pas produire de brouillage, et
- (2) l'utilisateur de l'appareil doit accepter tout brouillage radioélectrique subi, même si le brouillage est susceptible d'en compromettre le fonctionnement.

For FCC and IC Regulatory Information, use the display terminal to navigate to Menu > Legal Info.

Getting Started

What to Expect When Operating Your Pool Heater

Follow this flow chart to maintain good water quality and to protect pool users and heater.



Specifications

Heater Construction

Figure 1

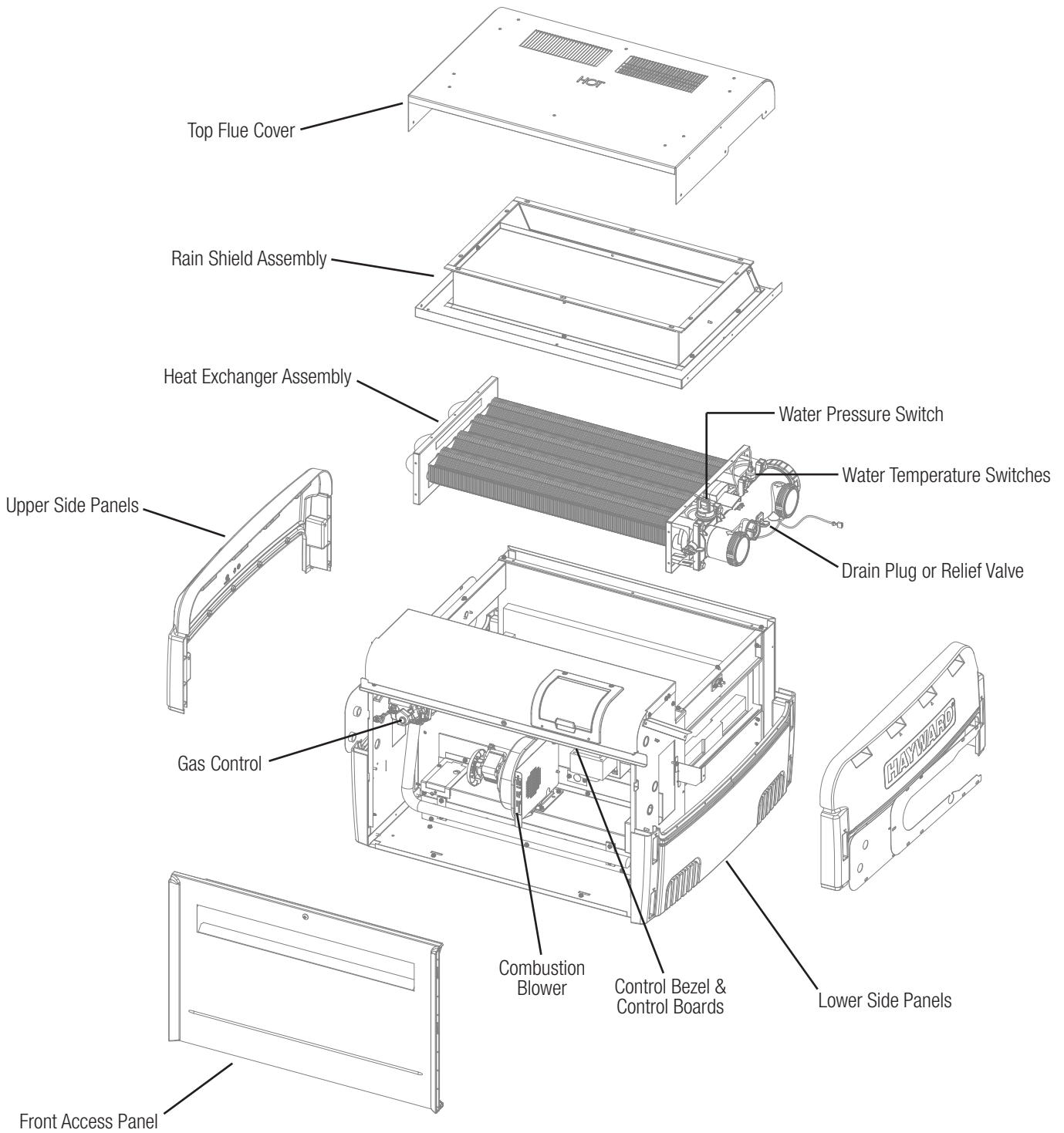



Features

- 120 or 240VAC, 60Hz, 1-phase, 5.5A maximum current
- Forced draft combustion with silicon nitride hot surface ignition
- Cupronickel water tubes standard
- Integral low loss bypass. **Maximum water flow for all models is 125 GPM.**

Table 1: Specifications

Model	Gas Input (Natural or Propane)	Minimum Water Flow	Thermal Efficiency	Heater Width	Heater Weight
	but/hr	GPM	%	in.	lbs.
135	135,000	20	82	19	135
150	150,000	20	82.7	19	135
200	199,900	20	83	22	140
250	250,000	25	84	25	165
400	399,900	30	84	34	195
500	500,000	40	83	40	245
250ASME	250,000	25	84	28	195
400ASME	400,000	30	84	36.5	225
500ASME	500,000	40	83	40.5	260

Table 2: Gas Requirements

Operating Pressures	Natural Gas (inwc)	Propane Gas (inwc)
Gas Manifold Pressure*	1.8 - 2.2	6.8 - 7.0
Gas Inlet Pressure, Minimum	4.5	10.0
Gas Inlet Pressure, Maximum	10.5	13.0
Gas Orifice Drill Sizes	#25	#43
Gas Orifice Drill Sizes (135kbtu/hr)	0.143 in	2.10 mm
Gas Orifice Drill Sizes (500kbtu/hr)	#22	2.3 mm

* Pressure range for allowable heating value variation

Dimensions

Figure 2

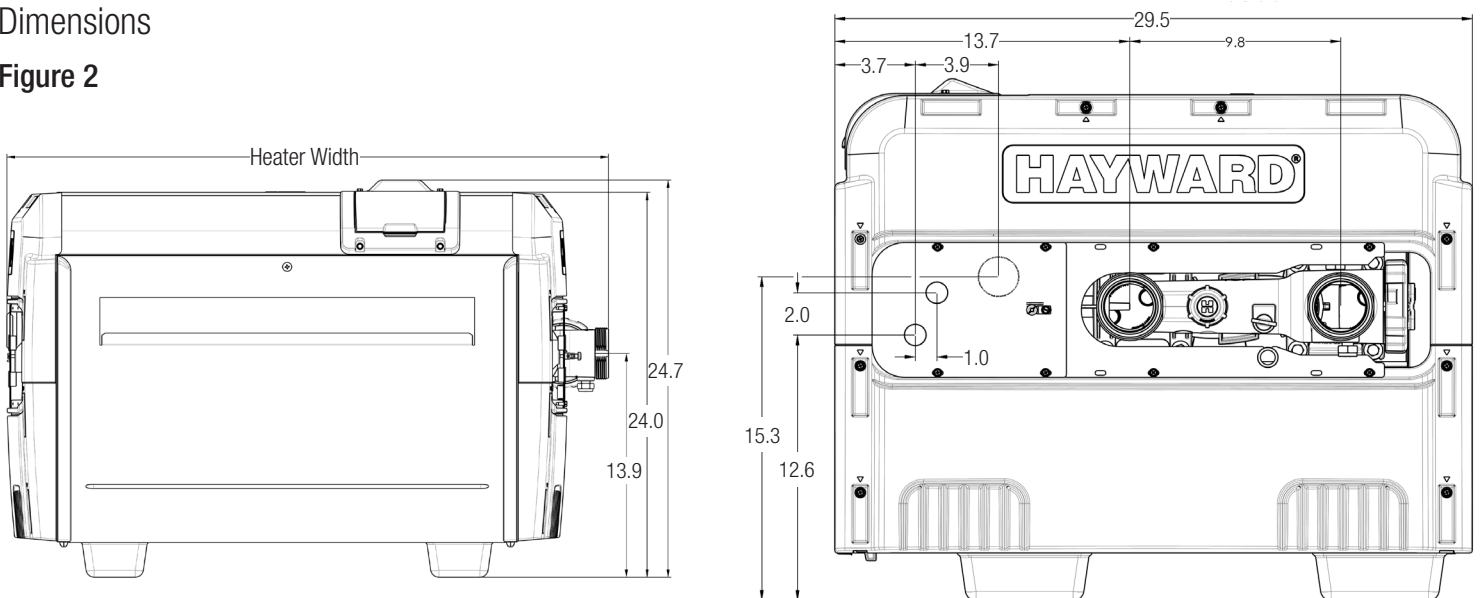

Wiring Connection Diagrams



⚠ WARNING – Risk of Electric Shock. Before working on any electrical equipment, turn off power supply to the equipment.

⚠ WARNING – Risk of Electric Shock. All electrical wiring MUST conform to applicable local codes, regulations, and the National Electric Code (NEC). Hazardous voltage can cause death, shock, burn, and/or serious property damage. To reduce the risk of electric shock, do NOT use an extension cord to connect unit to electric supply. Provide a properly located electrical receptacle. To reduce the risk of electric shock replace damaged wiring immediately. Locate conduit to prevent abuse from lawn mowers, hedge trimmers and other equipment. Do NOT ground to a gas supply line.

HS135FD Heaters

Wiring Connection Diagram / Schéma de Connexion de Câblage HS135FD Gas Heaters / Chaudière Gas à HS135FD

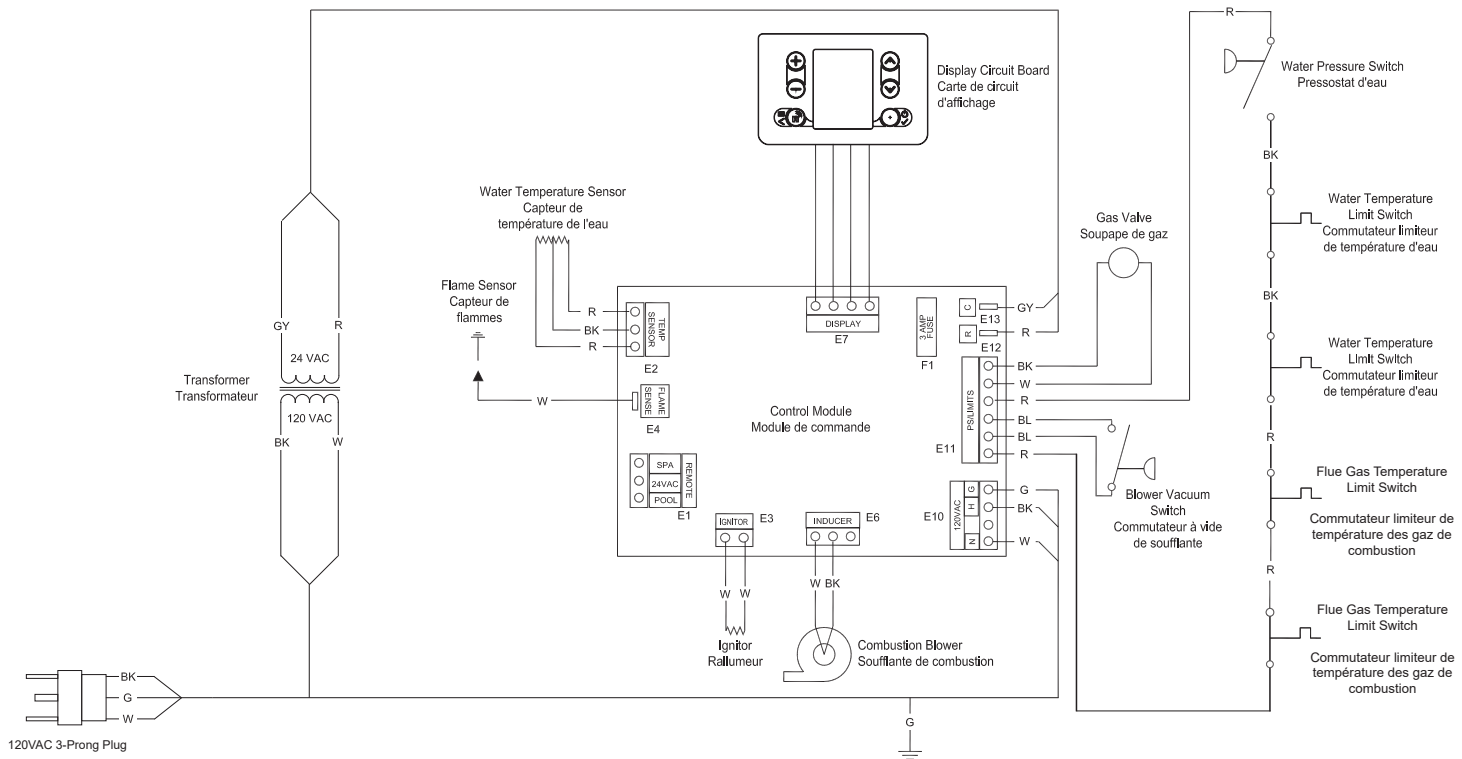

NOTE:

1. If any of the original wire supplied with the heater must be replaced, it must be replaced with 18 AWG, UL or CSA approved wire, rated for 600V and 105°C.

REMARQUE :

1. Si tout fil fourni initialement avec le réchauffeur doit être remplacé, il faut le remplacer par un fil de calibre 18 AWG, approuvé UL ou CSA, homologué pour 600 V et 105°C.

BK	black	noir
BL	blue	bleu
BR	brown	marron
G	green	vert
GY	gray	gris
O	orange	orange
R	red	rouge
V	violet	violet
W	white	blanc
Y	yellow	jaune

HS150FD - HS500FD Heaters

Wiring Connection Diagram / Schéma de Connexion de Câblage HS150FD-HS500FD Gas Heaters / Chaudière Gas à HS150FD-HS500FD

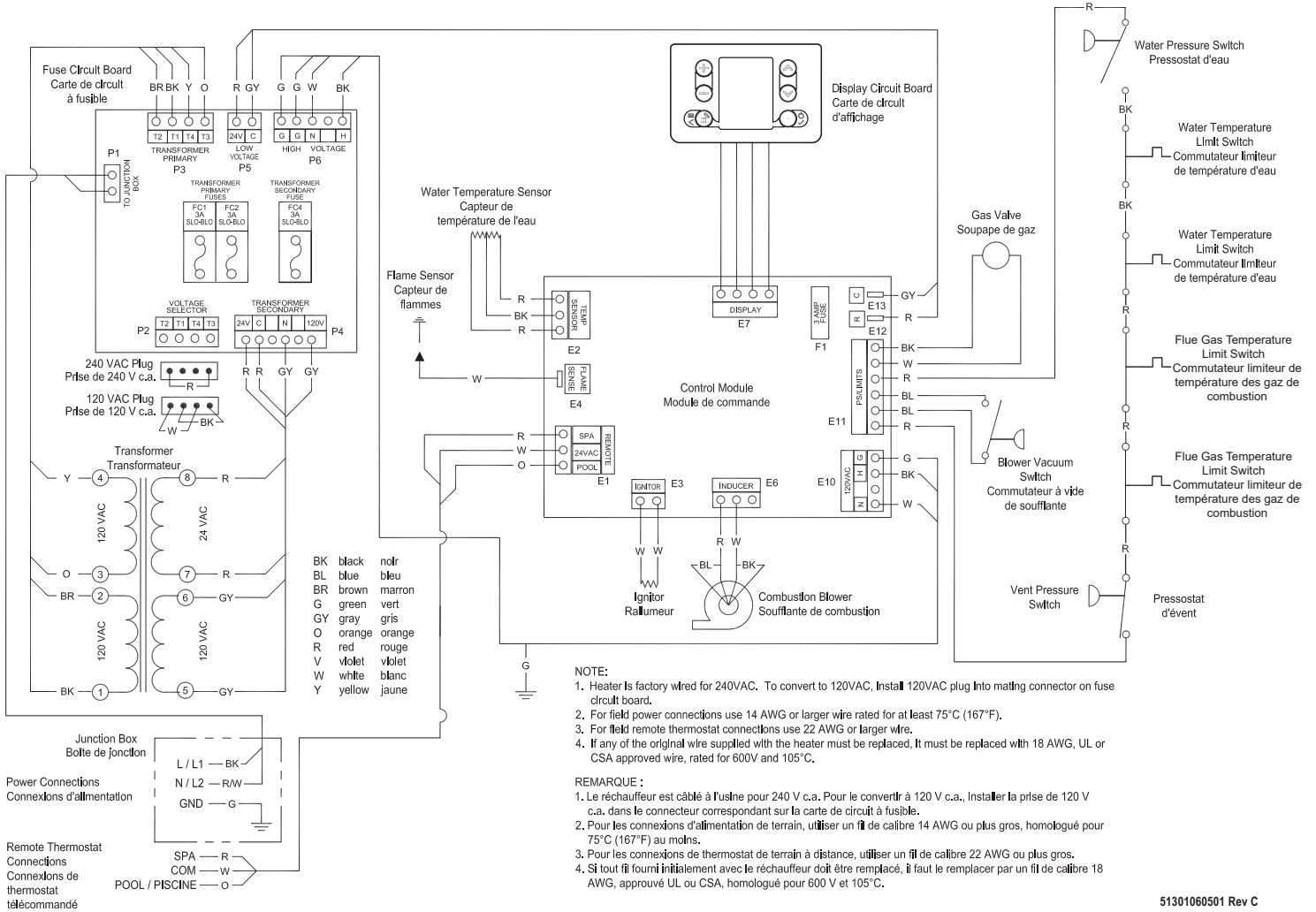

51301060501 Rev C



Installation

This manual contains instructions to install, operate, maintain, troubleshoot, and replace parts of swimming pool/spa/hot tub heaters. It is strongly recommended that the installer read the manual before installing the swimming pool/spa/hot tub heater. After reviewing this manual, contact tech services or a local Hayward representative with any questions. After heater installation, the installer should leave all manuals with the consumer for future reference.

⚠ ATTENTION – The installation instructions are intended for the use of a qualified technician, specifically trained and experienced in the installation of this type of heating equipment. Some states or provinces require that installer be licensed. If this is the case in the state or province where heater is located, the contractor must be properly certified.

THE USE OF A POOL COVER IS RECOMMENDED. A pool cover reduces heat loss, conserves chemicals, lowers the load on filter systems and may provide a valuable safety feature.

EQUIPMENT INSPECTION: After receiving the heater, inspect the heater carton(s) for damage. Note any damage to carton(s) upon arrival. Remove the heater from the carton(s), inspect it, and advise the carrier of any damages at once.

Unboxing the Heater

To remove the heater from the shipping carton:

1. Remove the corrugated carton from the heater. The carton, top pad, bottom pad, and the four corner posts can be recycled.
2. There are four (4) external screws used to secure the heater to the wood pallet. All four must be removed to separate the heater from the pallet.
3. To access the four (4) internal screws (See Figure 3), open the front access panel by removing the single top screw. Then, remove the two (2) screws and brackets which hold the heater base pan to the pallet. Next, open the rear access panel by removing the four (4) screws holding this panel. Then remove the two (2) screws and brackets which hold the heater base pan to the pallet.
4. Lift the heater off the corrugated bottom pad and off of the pallet. Discard bottom corrugated tray and pallet appropriately.

Figure 3: Front and Rear Shipping Screws

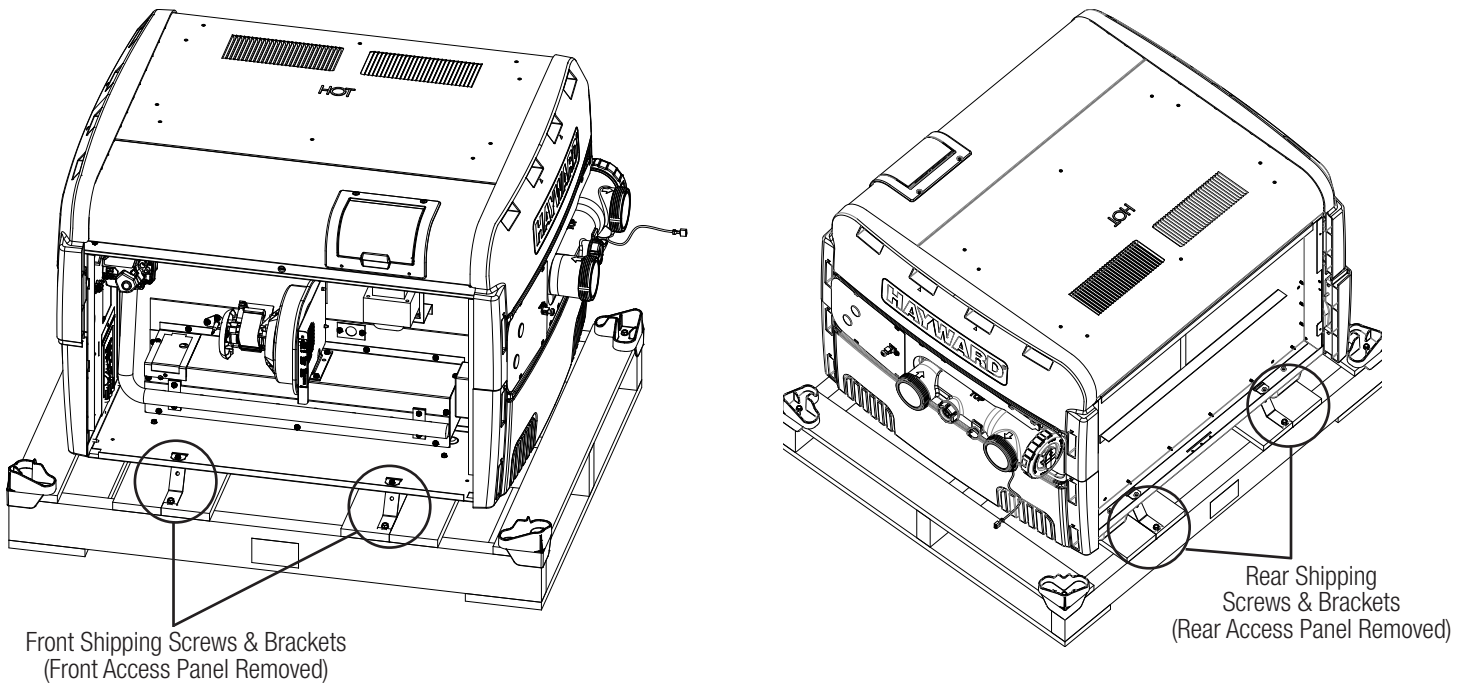

Sprinkler Heads

The heater is designed to handle the wettest weather conditions of rain and high humidity. However, sprinkler heads force high-pressure water into the side of the unit, which may cause damage. Make sure there are no sprinkler heads near the heater that will spray on or into the unit. Many sprinkler systems are connected to a well system with water high in minerals (sulphur, salt and other aggressive contaminants) that will leave a buildup on the unit and electronics causing corrosion and shortening life.



⚠ ATTENTION – Damage from sprinkler interaction is not covered under the warranty agreement. Make sure that sprinklers are placed at a sufficient distance away so that normal wind will not carry the mist into the heater.

⚠ ATTENTION – If located in an oceanfront area, the heater should be placed out of direct spray of sand and salt to prevent clogging, damage, and corrosion to the unit. You may also consider protecting the unit by creating a physical barrier outside of the minimum clearances between the unit and the prevailing beach front wind. Damage caused by sand or salt spray is not covered by the warranty.

Locating the Heater

- Locate the pool/spa heater in an area where leakage from the heat exchanger or connections will not damage the area adjacent to the heater or to the structure. When such locations cannot be avoided, install a suitable drain pan with a drain outlet under the heater. The pan must not restrict airflow.
- This heater must be installed at least five (5) feet from the inside wall of a pool (in-ground or above ground), spa, or hot tub unless separated from the pool/spa/hot tub by a solid barrier.
- The heater must be installed such that the location of the exhaust gas vent assembly outlet relative to adjacent public walkways, adjacent buildings, openable windows, and building openings complies with the National Fuel Gas Code (ANSI Z223.1/NFPA 54) and/or CAN/CGA B149 installation codes.

To prepare the area for heater installation, you must have a

1. Level surface for proper rain water draining and removal.
2. Suitable electrical supply line. See rating plate on the heater for electrical specifications. A junction box is not needed at the heater; connections are made inside the unit electrical compartment. Minimum wire size to be selected per NEC.
3. Electric disconnect switch that will interrupt all power to the unit. This switch **MUST** be within line of sight of the heater.

NOTE: The heater does not require additional vent piping when installed outdoors.

When choosing your heater location:

1. Do not install in a location where growing shrubs may in time obstruct a heater's combustion air and venting areas.
2. Do not install this appliance under an overhang less than 72 inches from the top of the appliance. The area under the overhang must be open on three (3) sides.
3. Do not install the heater where water spray from ground level can contact the heater. The water could reach the controls causing electrical damage.
4. Do not install under a deck.
5. Do not install within 24 inches of any outdoor HVAC equipment.
6. Do not install where water may run-off a roof directly onto the heater. A gutter may be needed above the heater.

⚠ CAUTION – Make sure the heater is not located where large amounts of water may run-off from the roof into the unit. Sharp sloping roofs without gutters will allow rainwater and debris through the unit. Failure to follow the instructions may result in property damage and void warranty.

7. Any enclosure around the heater must provide a combustion air vent large enough to accommodate input ratings of all gas appliances in the enclosure. See "Air Supply" for more details.
8. For minimum exhaust vent clearances for all building openings, including but not limited to vented eaves, doors, windows, or gravity inlets (See Figure 4). In Canada, the heater must be installed with the top of the vent at least 10 feet (3 m) below, or to either side of, any opening into a building.

OUTDOOR INSTALLATION AND SERVICE CLEARANCES: For outdoor installations, maintain the installation clearances from combustible materials and service clearances shown Table 3 and Figure 4. Do not install heater in a closet or enclosed space (consult NFGC). These clearances provide for proper combustion air and flue product exhaust.

Equipment Pad

Place the heater on a level surface such as concrete or a fabricated slab (pad). This allows proper drainage of condensation and rainwater from the base of the unit. If possible, the pad should be placed at the same level or slightly higher than the filter system equipment pad.

Flooring

This heater may be installed on either non-combustible flooring or combustible flooring that does not reduce the bottom clearance of the heater. Ultralite™ or equivalent concrete-over-foam HVAC pads are acceptable.

Heater Panel	Outdoor	Indoor
Top	Unobstructed	36
Front	18	18
Back*	6	6
Water Side Connection	12	12
Opposite Water Side Connection	6	6
*If the heater is to be installed with vinyl siding at back, increase the clearance in Table 3 to 12 inches to avoid potential discoloration of siding		

NOTE: The HS135FD heater is not rated for indoor applications

Figure 4: Outdoor Minimum Clearances

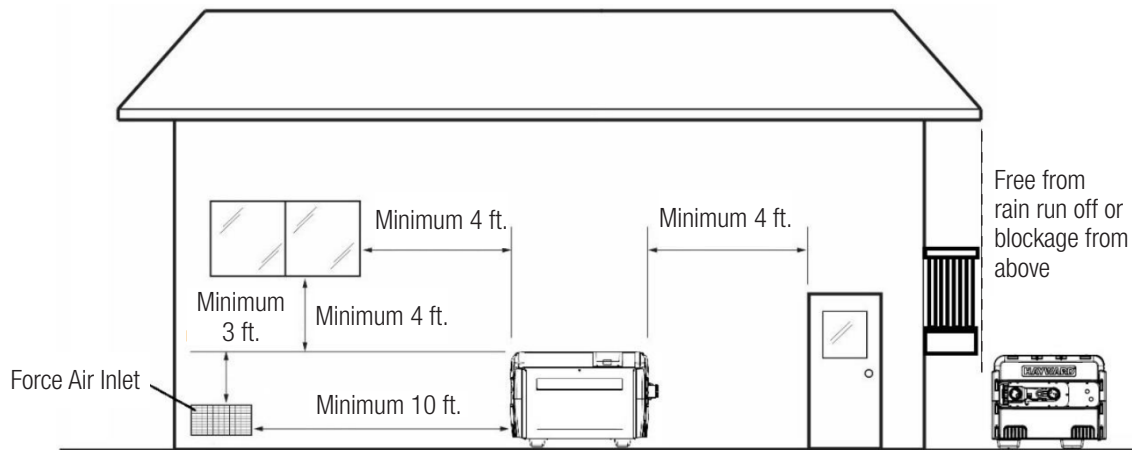

Anchoring

The heater is equipped for installation of factory supplied tie-down brackets when required by local codes. Follow all relevant local, state and national requirements regarding wind load anchoring. The brackets are shipped in the consumer kit. You will need the following to complete the installation:

- Tie-down brackets (FACTORY-SUPPLIED, qty = 4)
- Sheet metal screws (FACTORY-SUPPLIED, qty = 4)
- Concrete tapping screws (FIELD-SUPPLIED, Tapcons®, qty = 4, stainless steel, size to be ¼" diameter with a minimum length of 1-½")
- Fender washers (FIELD SUPPLIED, stainless steel, qty = 4, size to be at least 1-½")

Installing Tie-Down Brackets

1. Locate the tie-down brackets and the sheet metal screws.
2. Obtain the Tapcons®. Be sure the overall length of the concrete tapping screw is at least 1-½".
3. Remove the front (1 screw) and rear access panel (4 screws).
4. Position the heater on the pad so that all Tapcons® can "bite" into the pad. Observe local codes regarding pad construction, some jurisdictions specify a minimum thickness for concrete pads.
5. Position the tie-down brackets into the slots in the front of the heater base pan as shown in Figure 5a. Secure the bracket to the heater base pan using the sheet metal screws.
6. Install the Tapcons® through the inner set of holes in the tie-down brackets into the pad (See Figure 5b).
7. Repeat Steps 6 and 7 at the rear of the heater.
8. When the four brackets are secure to the heater and the pad, re-install the front and rear access panels.

Figure 5a: Tie-Down Installation Locations

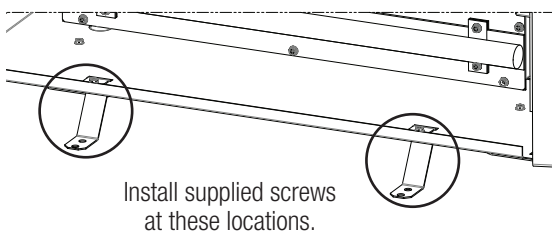
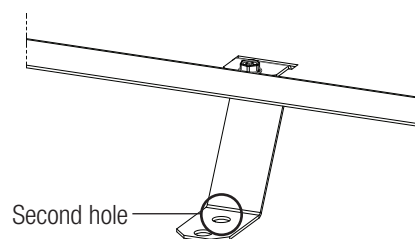

Figure 5b: Use second hole for ground mount of tie-down brackets with 2 holes





Gas Conversion

Where permitted by local codes, the factory-installed gas train may be changed from natural gas to propane or from propane to natural gas, using the appropriate conversion kits (See Table 4). Gas conversion kits shall be installed by a qualified service agency in accordance with the manufacturer's instructions and all applicable codes and requirements of the authority having jurisdiction. Detailed instructions are included with each kit.

Table 4: Gas Conversion Kits

		Heater Size					
		135	150	200	250	400	500
Gas Conversion	Natural Gas to Propane	FDXLGCKW135NP	FDXLGCKW150NP	FDXLGCKW200NP	FDXLGCKW250NP	FDXLGCKW400NP	FDXLGCKWS00NP
	Propane to Natural Gas	FDXLGCKW135PN	FDXLGCKWISOPN	FDXLGCKW200PN	FDXLGCKW250PN	FDXLGCKW400PN	FDXLGCKWS00PN

Altitude of Installation

Heaters may be installed up to 2,000 feet above sea level AS SHIPPED FROM THE FACTORY. The High Altitude Conversion Kit (FDXLHAK1931) is available for installations at altitudes greater than 2,000 feet. High altitude conversion kits shall be installed by a qualified service agency in accordance with the manufacturer's instructions and all applicable codes and requirements of the authority having jurisdiction. Detailed instructions are included with each kit.

NOTE: The HS135FD model is not rated for high altitude installations.

⚠ WARNING – Failure to comply with the appliance gas conversion or high altitude installation instructions and service instructions may result in equipment damage, fire, asphyxiation, or carbon monoxide poisoning. Exposure to products of incomplete combustion (carbon monoxide) can cause cancer and birth defects or other reproductive harm.

Air Supply

Indoor installations and installations in outdoor shelters (confined spaces) must have adequate combustion and ventilation air openings to ensure proper heater operation. These openings must be sized according to the requirements stated in this section:

- Air openings must never be obstructed when heater is in operation.
- Confined spaces shall be provided with two (2) permanent openings, one within 12 inches of the bottom and one within 12 inches of the top of the enclosure.
- The openings shall communicate directly, or by ducts, with the outdoors or spaces (crawl or attic) that freely communicate with the outdoors.
- Ducts shall be of the same cross-sectional area as the free area of the openings to which they connect. The minimum dimension of rectangular air ducts shall not be less than 3 inches.
- When air blowers are used in spa/hot tub installations and are located in proximity to the heater, caution must be observed to ensure sufficient combustion air is available to the heater for proper combustion. A separate blower air duct is recommended.
- Minimum installation clearances shown in Table 5 apply.

For Horizontal Ducts: Each opening shall have a minimum free area of 1 square inch per 2,000 btu/hr of total input See Table 5 and Figure 6a.

For Vertical Ducts: Each opening shall have a minimum free area of 1 square inch per 4,000 btu/hr of total input rating of all equipment in the enclosure. See Table 5 and Figure 6b.

For Below Ground installation (in a pit, for use with natural gas only): Combustion and ventilation air openings must be provided (See Figure 7).

Table 5: Combustion and Ventilation Air Requirements*

Free Area per Total Btu Requirement	Free Area Required for Both Combustion and Ventilation Air Openings (sq. in.)					
	HS135FD	HS150FD	HS200FD	HS250FD	HS400FD	HS500FD
1 sq. in. per 2,000 Btu/hr (Outdoor Air thru Horz duct)	67.5	75	100	125	200	250
1 sq. in. per 4,000 Btu/hr (Outdoor Air direct or thru Vert duct)	33.75	37.5	50	62.5	100	125

* For detailed methods of providing combustion and ventilation air, see latest edition of the National Fuel Gas Code (ANSI Z223.1/NFPA 54)

Figure 6: Air from Outside Building Installation

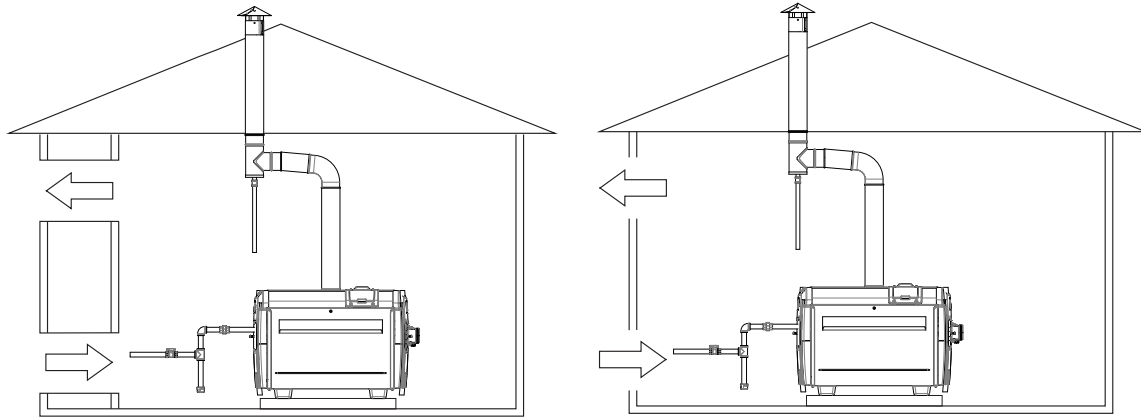

A) 1 sq. in. per 2,000 Btu/hr of Total Input B) 1 sq. in. per 4,000 Btu/hr of Total Input

Figure 7: Air Below-Ground (Pit for Natural Gas Installations ONLY)
 1 sq. in. per 4,000 Btu/hr of Total Input

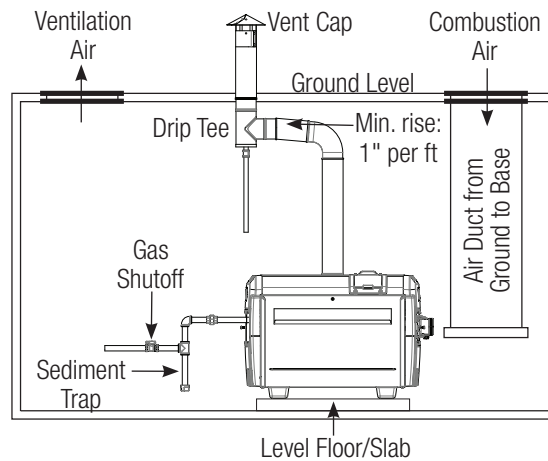



Flue Gas Venting

OUTDOOR INSTALLATION:

For installation outdoors, no additional venting is required for operation. Ensure top of unit remains unobstructed.

INDOOR INSTALLATION WITH NEGATIVE (CAT I) OR POSITIVE (CAT III) PRESSURE VENTING SYSTEMS: The heater is designed such that it may be vented using either a negative-pressure or a positive-pressure venting system. The appropriate system of venting for a particular site will depend on many factors such as vent termination needs (horizontal/vertical), clearance of vent termination, length of vent and the cost of venting system. Table 6 and Table 7 (CAT I) and Table 9 (CAT III) list the required indoor venting kits available for each system. Multiple forced or induced draft units should never be vented using common venting or vent terminations. Never common vent this heater with other gas-burning appliances.

Negative Pressure (Vertical or Horizontal, CAT I) Venting

Vertical-Only CAT I

Table 6: Vertical-Only CAT I Venting Kits By Model

Kit P/N	Applicable Heater Model	Description	Vent Pipe Application	Vent Pipe Material	Vent Termination Requirements
UHXNEGVT11506	HS150FD	Negative pressure CAT I, vertical venting applications	Vent pipe to be installed according to the Category I venting tables in the National Fuel Gas Code (ANSI Z223.1/NFPA 54)	Single or double wall, galvanized, non-sealed vent pipe	<ul style="list-style-type: none"> Vertical only Termination above roof of house/building
UHXNEGVT12006	HS200FD				
UHXNEGVT12506	HS250FD				
UHXNEGVT14008	HS400FD				
UHXNEGVT15008	HS500FD				

Horizontal-Only CAT I

Table 7: Horizontal-Only CAT I Venting Kits

Kit P/N	Description	Vent Pipe Application	Vent Pipe Material	Vent Termination Requirements
UHXNEGVMV300	Negative pressure CAT I, horizontal venting applications	Vent pipe to be installed according to the Category I venting tables in the National Fuel Gas Code (ANSI Z223.1/NFPA 54)	Single or double wall, galvanized, non-sealed vent pipe	Horizontal only
UHXNEGVMV600				

Table 8: Maximum Equivalent Horizontal Pipe Length (ft)

TOTAL BTU/HR INPUT*	Power Venting Kit and Vent Pipe Diameter (in)					
	UHXNEGVMV300			UHXNEGVMV600		
	4"	5"	6"	5"	6"	8"
150,000	138	235	320	400	--	--
200,000	84	135	185	230	--	--
250,000	40	75	110	135	220	300
275,000	25	63	90	110	185	260
310,000	--	54	74	91	146	216
400,000	--	--	--	54	87	134
500,000	--	--	--	--	55	90
610,000	--	--	--	--	--	66

*For applications at altitudes, follow manufacturer's input instructions and/or altitude derate directions from the latest addition of NFPA® 54 National Fuel Gas Code.



Positive Pressure (Horizontal or Vertical, CAT III) Venting

Table 9: Horizontal or Vertical CAT III Venting Kits By Model

Kit P/N	Applicable Heater Model	Description	Vent Pipe Application	Vent Pipe Material	Vent Termination Requirement
UHXPOSHZ11506	HS150FD	Positive pressure CAT III horizontal or vertical venting applications	<ul style="list-style-type: none"> • 50 ft. max with 1 elbow, • 40 ft. max with 2 elbows, • 30 ft. max with 3 elbows" 	Single or double wall sealed stainless steel vent pipe	Horizontal or vertical termination immediately outside of house or building wall
UHXPOSHZ12006	HS200FD				
UHXPOSHZ12504* UHXPOSHZ12506	HS250FD				
UHXPOSHZ14006** UHXPOSHZ14008	HS400FD				
UHXPOSHZ15006**	HS500FD				

* Kit must be accompanied by UHXHFA004 or UHXDVA004

** Kit must be accompanied by UHXHFA006 or UHXDVA006

When installed according to the following instructions, heaters meet the criteria for Category III venting.

VENT SIZING: Vent pipe diameter must match the vent pipe diameter on the heater (see Table 8). The vent pipe must be single or double-wall stainless steel sealed vent as listed in Table 9. Double-wall vent must be used in non-conditioned spaces. The maximum total length of vent pipe, and number of 90-degree elbows cannot exceed the limits specified in Table 10. The venting system must be installed in accordance with the vent manufacturer's installation instructions and guidelines. The installer is urged to visit the vent system manufacturer's website (see below) and review the installation information found there.

VENT TERMINATION: The vent system must terminate with a vent terminal approved for this pool heater. Termination may be either horizontal or vertical. See Table 10 for approved vent terminals and orientations.

OBTAINING VENT PIPE AND TERMINATIONS: A variety of vent components, including terminals, elbows, and straight lengths, are available for use with this appliance. Approved parts are listed in Table 9 and in the service part instructions supplied with any service kit. They can be ordered directly from the manufacturer, or one of their authorized dealers. The appliance adapter needed to attach the heater to vent piping can be ordered directly from Hayward. Check your service parts list to identify the appropriate adapter. To locate an authorized dealer for venting parts, contact the manufacturer at:

Selkirk Corporation
Heatfab Division
130 Industrial Blvd
Turners Falls, MA 01376
(800) 772-0739

www.heatfab.com
Heatfab Saf-T Vent EZ Seal (CI Plus)

Table 10: Positive-Pressure (CAT III) Indoor Vent Maximum Vent Lengths

Number of 90° Elbows	Maximum Vent Pipe Length, Horizontal & Vertical (ft.)
0	50
1	50
2	40
3	30

Gas Supply

- The heater is shipped from the factory with the gas connection located on the left side of the heater cabinet.
- Insert the pipe to the gas valve through the grommet in the cabinet side (See Figure 9).
- Install a union outside the heater cabinet for easy removal of the gas manifold assembly during service.
- A CSA certified main gas shutoff valve must be installed outside the cabinet and within 6 feet of the heater.
- This valve must have an I.D. large enough to supply the proper amount of gas volume to the heater (See Figure 8).
- Reduction of gas supply pipe or tubing to the inlet to the heater gas valve must be made at the valve only and must match the valve inlet size ($\frac{3}{4}$ " or 1" NPT).
- If there is more than one appliance installed on the gas line, consult the local gas company or appropriate technical service for the proper gas line size.

⚠ CAUTION – Apply joint compound (pipe dope) sparingly and only to the male threads of pipe joints. Do not apply joint compound to the first two threads. Use joint compounds resistant to the action of liquefied petroleum gas. Do not overtighten the gas inlet pipe or damage may result.

⚠ NOTICE – Use Only CSA approved flexible outdoor gas appliance connectors marked with BTUH capacity (which must be equal to or greater than the heater rated input) and appropriate gas type (natural and/or LP).

Figure 8: Gas Piping with Shut Off and Trap

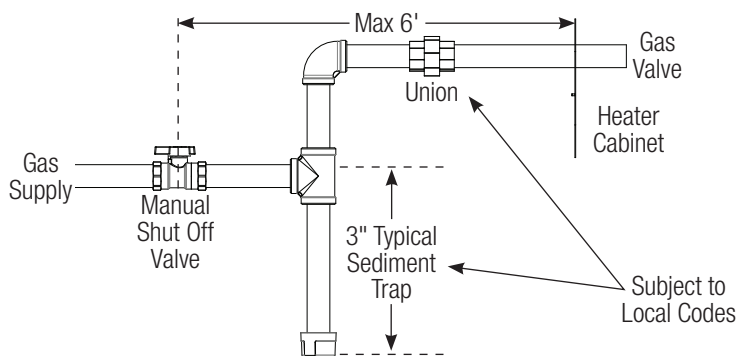
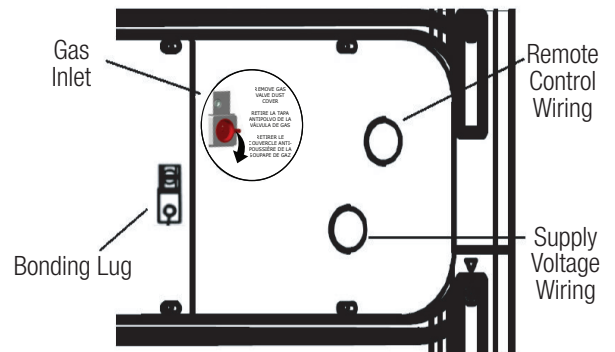

Figure 9: Gas Entry and Junction Box Cover



NATURAL GAS: The gas meter must have the capacity to supply enough gas to the pool heater and any other gas appliances if they are on the same pipeline (Example: 225 meter = 225,000 BTUH). If needed, consult the local gas utility to confirm meter and regulation sizes. Natural gas must be “pipeline quality” supplied from a natural gas utility company.

⚠ NOTICE – Manufacturer is not responsible for heaters that are damaged if connected to a natural gas well.

PROPANE GAS: All propane gas tanks must be located outdoors and away from pool/spa structure and in accordance with the standard for storage and handling of propane gas, ANSI/NFPA 58 (latest edition) and applicable local codes. If the propane gas tank is installed underground, the discharge of the regulator vent must be above the highest probable water level. Propane tanks must have sufficient capacity to provide adequate vaporization for the full capacity of the equipment at the lowest expected temperatures. Consult a propane expert for accurate pipe and pressure sizing. Make sure that first and second stage regulators are large enough to handle the BTUH input listed for the heater(s) being used.

⚠ NOTICE – Manufacturer is not responsible for heaters that soot due to improper gas line or propane tank sizing or regulation control resulting in improper gas volume.



HAYWARD®

GAS SUPPLY AND PIPING: To properly size the gas piping for the heater, refer to Tables 11, 12, 13, and 14, depending on natural or propane gas and single-stage or two-stage regulation. Follow local gas codes for proper gas line material selection (copper, iron, plastic, etc.). It is VERY IMPORTANT when installing a propane heater on a two-stage regulation system to follow the gas line sizing data in Tables 13 or 14 without exception.

Table 11: Natural Gas Pipe Sizing (dia. in.), Low Pressure, Single-Stage Regulation						
btu/hr Input		150,000	200,000	250,000	400,000	500,000
Gas Line Material		Iron or Plastic Pipe	Iron or Plastic Pipe	Iron or Plastic Pipe	Iron or Plastic Pipe	Iron or Plastic Pipe
Distance from Gas Meter to Gas Valve Inlet (ft.)	0 to 50	3/4	1	1	1-1/4	1-1/4
	50 to 100	1	1	1-1/4	1-1/4	1-1/2
	100 to 200	1-1/4	1-1/4	1-1/4	1-1/2	2
	200 to 300	1-1/4	1-1/4	1-1/2	2	2

Based upon an inlet gas pressure of 0.5 psig or less at a pressure drop of 0.5 inwc

Table 12: Propane Gas Pipe Sizing (dia. in.), Low-Pressure, Single-Stage Regulation									
btu/hr Input		150,000		200,000		250,000		400,000	500,000
Gas Line Material		Iron Pipe	Tubing	Iron Pipe	Tubing	Iron Pipe	Tubing	Iron Pipe	Iron Pipe
Distance from Tank Regulator to Gas Valve Inlet (ft.)	0 to 50	3/4	7/8	3/4	7/8	1	1-1/8	1	1
	50 to 100	3/4	1-1/8	1	1-1/8	1	1-1/8	1-1/4	1-1/4
	100 to 200	1	1-1/8	1	--	1-1/4	--	1-1/4	1-1/4
	200 to 300	1	--	1-1/4	--	1-1/4	--	1-1/2	1-1/2

Based upon an inlet gas pressure of 11 inwc at a pressure drop of 0.5 inwc

Table 13: Natural Gas Pipe Sizing (dia. in.), High-Pressure, 2-Stage Regulation							
btu/hr input		150,000	200,000	250,000	400,000	500,000	
Gas Line Material		Iron or Plastic Pipe	Iron or Plastic Pipe	Iron or Plastic Pipe	Iron or Plastic Pipe	Iron or Plastic Pipe	
Distance of 1st Stage then 2nd Stage to Gas Valve Inlet (ft.)	First Stage*	0 to 50	1/2	1/2	1/2	1/2	
		50 to 100	1/2	1/2	1/2	3/4	
		100 to 150	1/2	1/2	1/2	3/4	
	Second Stage**	0 to 10	3/4	3/4	3/4	3/4	1

*Based upon an inlet gas pressure of 2 psig at a pressure drop of 1 psi

** Based upon an inlet gas pressure of 10 inwc at a pressure drop of 0.5 inwc

Table 14: Propane Gas Pipe Sizing (dia. in.), High-Pressure, 2-Stage Regulation											
btu/hr Input		150,000		200,000		250,000		400,000		500,000	
Gas Line Material		Iron Pipe	Tubing	Iron Pipe	Tubing	Iron Pipe	Tubing	Iron Pipe	Tubing	Iron Pipe	Tubing
Distance or 1st Stage then 2nd Stage to Gas Valve Inlet (ft.)	1st Stage*	0 to 50	1/2	1/2	1/2	1/2	1/2	1/2	1/2	1/2	1/2
		50 to 100	1/2	1/2	1/2	1/2	1/2	1/2	1/2	5/8	1/2
		100 to 150	1/2	1/2	1/2	1/2	1/2	1/2	1/2	5/8	1/2
	2nd Stage**	0 to 10	1/2	5/8	1/2	5/8	1/2	3/4	3/4	7/8	3/4

*Based upon an inlet gas pressure of 10 psig at a pressure drop of 1 psi

** Based upon an inlet gas pressure of 11 inwc at a pressure drop of 0.5 inwc



Water Connections and Piping

REVERSING WATER CONNECTIONS: This heater is designed so that it can be installed with the water connections located on either the right or left side. Heaters are factory-shipped with right-side water connections. To move the connections to the left side, follow the instructions below. A trained service technician must perform these steps before the heater is installed.

▲ NOTICE - The heater is for use with pool and spa/hot tub water furnished by municipal water distribution systems only. Do not use with mineral water, sea-water (PPM>5000), or other non-potable waters which invalidate the warranty. Do not install any restriction in the water pipe between the heater outlet and the pool/spa with the exception of a three-way switching valve, in-line chlorinator and/or chlorinator check valve.

Before you begin, be aware that it is not necessary to remove the water header from the heat exchanger. When this procedure is complete, the water inlet will be located at the BACK of the heater and water outlet will be located at the FRONT.

1. Remove the front access panel and disconnect water temperature sensor plug from the ignition control board located inside the heater.
2. Remove screws and remove both of the upper plastic heater side panels (See Figure 10a). Note the wires that pass through a hole in the heater side panel go through a split-bushing, which will allow separation of the wires from the panel without disconnecting them.
3. Disconnect the two wires connecting the heater wire harness to the heat exchanger header. One is located on the water pressure switch and one is located on the temperature limit switch, both on the top of the header. Pull these wires into the heater cabinet from the hole in the right-hand metal side panel in the heater, and re-route them out through the corresponding left-hand metal side panel in the heater.
4. Remove the top flue cover (See Figure 10b).
5. Remove the screws securing the rain shield assembly to the heat exchanger assembly. Remove the rain shield assembly (See Figure 10b).
6. Pull the water temperature sensor wires out of the heater cabinet through the hole in the right-hand metal side panel.
7. Lift and rotate the heat exchanger 180°. Do not flip. Use care when setting the heat exchanger in place. Do not damage the white sealing gaskets or combustion chamber refractory. If damaged, these sealing surfaces must be repaired or replaced.
8. Route the water temperature sensor wires into the heater cabinet through the hole in the left-metal side panel, and re-connect to the ignition control board.
9. Reconnect the two wires connecting the heater wire harness to the water pressure switch and the temperature limit switch.
10. Reverse the above panel disassembly steps to reassemble the heater.



▲ WARNING - Explosion Hazard. Blockage of water flow from heater return to pool may result in fire or explosion causing property damage, personal injury, or loss of life.

Figure 10a: Screw Locations on Side of Unit

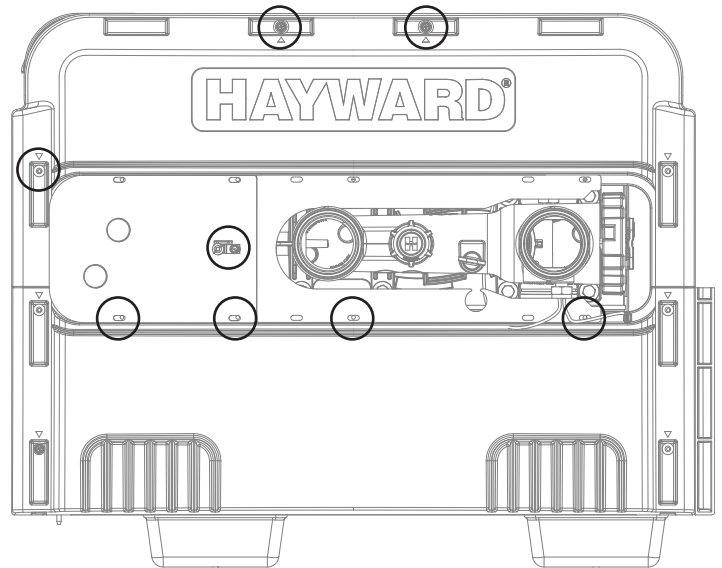

Figure 10b: Top and Heat Exchanger Removal

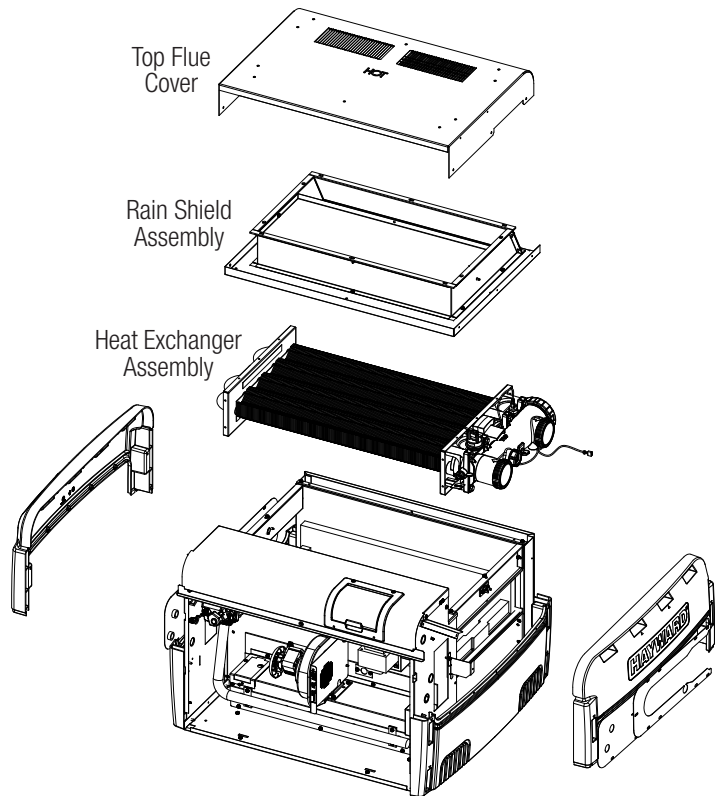
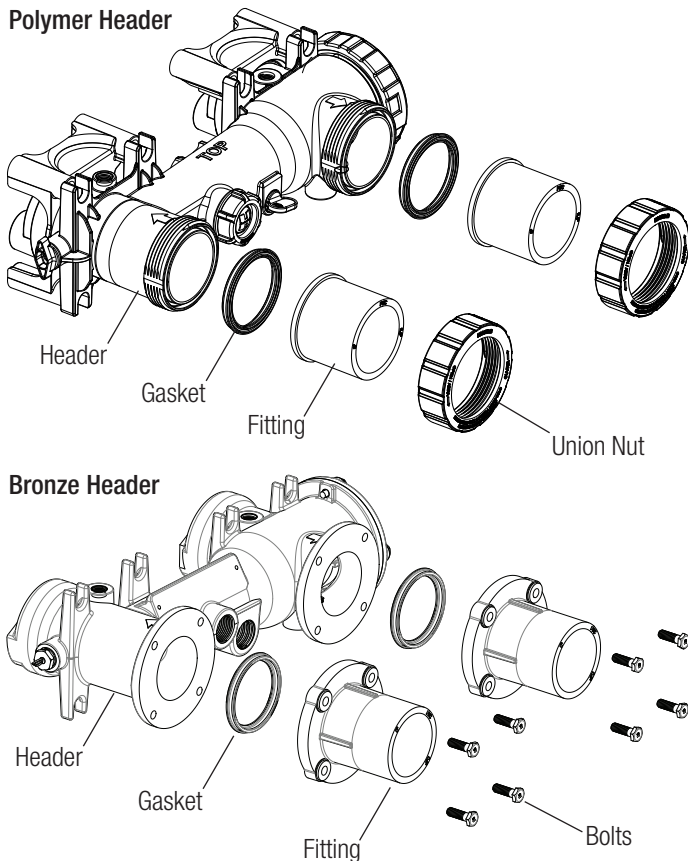
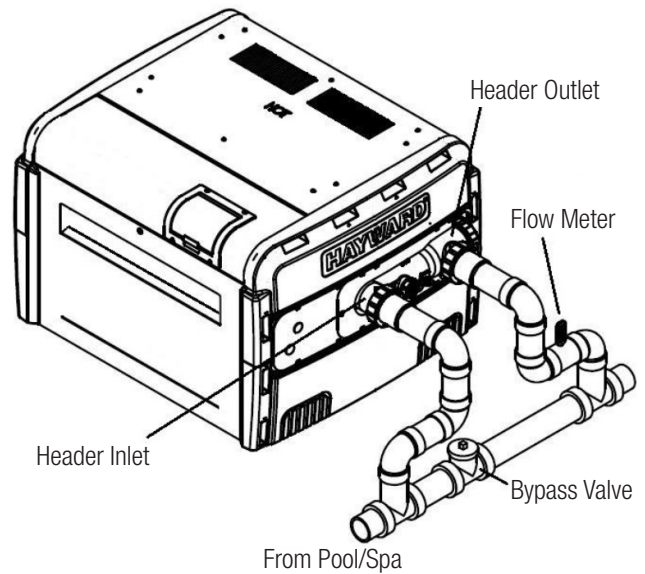

Figure 11: Water Connections

Figure 12: Bypass Valve(s)

MAKING WATER CONNECTIONS

- The heater is equipped with CPVC flanged pipe nipples to accommodate water piping to and from the pool or spa. These pipe nipples will accept piping with solvent welding (PVC glue).
- The fittings will accept either a 2" pipe or a 2-½" pipe fitting and seal to the heater header with rubber gaskets.
- On plastic headers, the fittings are secured in place with supplied plastic union nuts. On bronze headers (ASME models), the fittings are secured in place with bolts. Assemble these parts to the heater prior to plumbing.
- Tighten union nuts (or bolts) securely before gluing fittings to the ends of the pipe nipples (See Figure 11).
- The CPVC flanged pipe nipples must be installed on the heater inlet and outlet without modification.
- Pipe, fittings, valves, and any other element of the filter system may be made of plastic materials, if acceptable to the authority having jurisdiction.

USING BYPASS SYSTEM

Heat sinks, heat tapes, firemen switches, and check valves are not required on the heater. However, if there is any chance of back-siphoning of hot water when the pump stops running, it is suggested that a check valve be used on the heater outlet pipe down stream of bypass system. If the normal pump and filter system flow rate exceeds 125 GPM, then a manual bypass valve must be installed as shown in Figure 12.

The built-in bypass inside the header will maintain proper flow through the heat exchanger if the flow rate is within the range specified in Table 1. The minimum flow rate is to be calculated or measured with the in-floor cleaning system in use, if the pool is so equipped, as well as any other jets demands on the water flow. Damage caused by flow rates outside of the specified range will void the manufacturer's warranty.

To set the bypass valve: temporarily install a flow meter on the outlet line of the heater, then adjust the manual bypass valve until the flow rate through the heater is within the flow rate range specified. Once the manual bypass valve is set, note the position and remove the valve handle to prevent accidental adjustment.

▲ CAUTION – Improperly adjusted manual bypass valves will result in damage to the heater if the flow rates are not maintained under all operating conditions as specified in Table 1. The heat exchanger will fail and this damage will not be covered under the manufacturer warranty.

Typical Pool Piping Arrangements

Figure 13 illustrates a typical pool piping diagram and layout for the pool equipment. Figure 14 illustrates a multiple heater installation for very large pools with and without a manual bypass valve.

Figure 13: Typical Plumbing to Pool or Spa

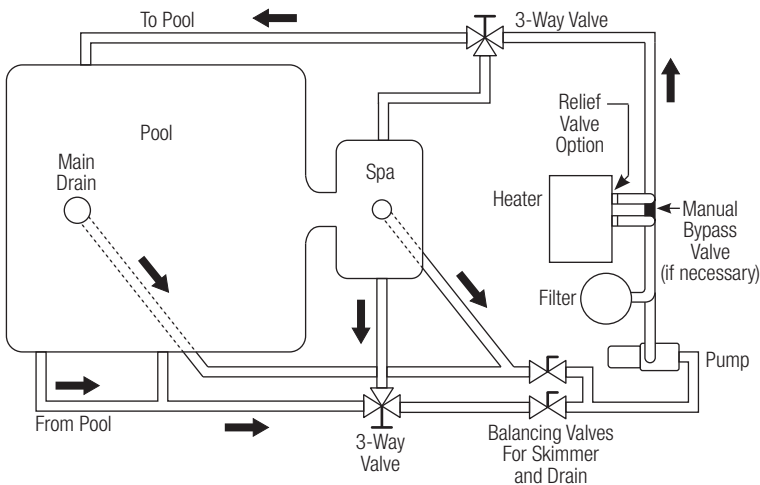
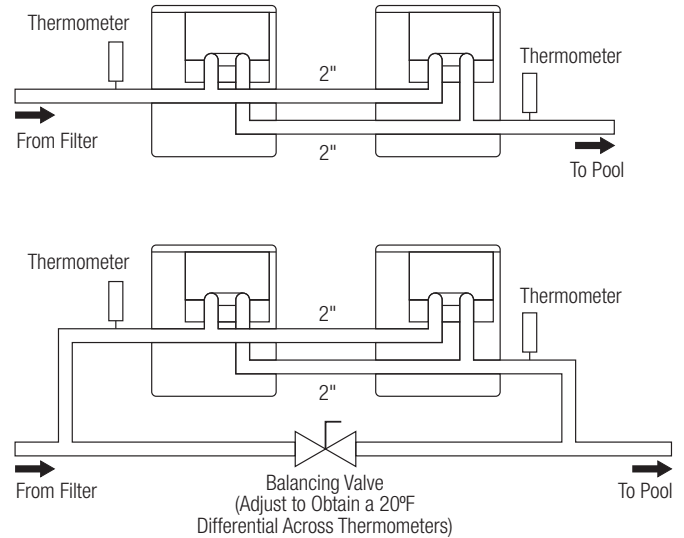
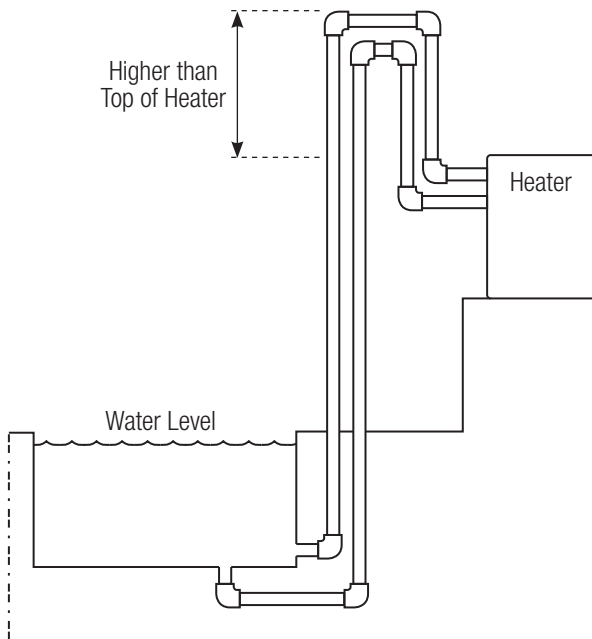

Figure 14: Multiple Heater System



INSTALLATION ABOVE POOL/SPA SURFACE: If the heater is installed less than three (3) feet above the surface of the pool/spa water, install eyeball fittings or directional flow fittings on the end of the return water line to the pool/spa. This creates adequate back pressure at the heater to operate the pressure safety switch when the pump is running. If the heater is installed more than three (3) feet above the surface of the pool/spa water, install a loop as shown in Figure 15 to prevent water drainage in the heater during a filter change. For installation above or below the pool/spa surface, refer to Operation section for proper pressure switch setup.

Figure 15: Installation Above Pool or Spa



AUTOMATIC CHLORINATORS AND CHEMICAL FEEDERS: If used, a chlorinator must be installed downstream from the heater in the pool return line as shown in Figure 16. Install a separate positive seal corrosion resistant check valve between the heater outlet and the chlorinator to prevent highly concentrated sanitizer from back-siphoning into the heater. Back-siphoning may occur when the pump is shut off and a pressure differential is created.

Figure 16: Automatic Chlorinator

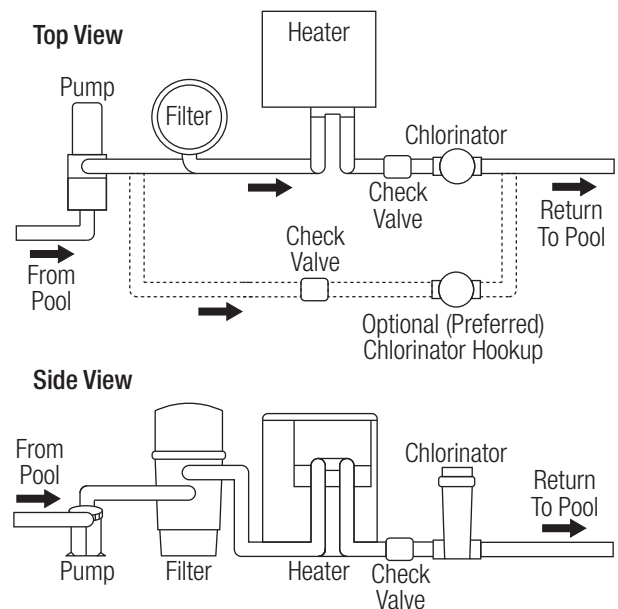

DRAIN VALVE INSTALLATION (ASME MODELS ONLY)

- If installing an ASME model heater, a ¾" brass drain valve must be installed.
- A drain valve is included separately with all ASME heaters.
- Apply pipe thread sealant or Teflon tape to the threads and install as shown in Figure 17.

PRESSURE RELIEF VALVE (ASME MODELS ONLY)

Please note that the drain valve must be installed BEFORE the pressure relief valve.

- If installing an ASME model heater, a ¾" pressure-relief valve having a discharge capacity greater than or equal to the Btu/hr input of the heater, and a pressure rating equal to or less than the working pressure must be installed. See the rating plate located inside the front access panel on the heater for the input rating and working pressure.
- An appropriate pressure relief valve is included separately with all ASME heaters.
- Apply appropriate pipe thread sealant or Teflon tape to the threads and assemble as shown in Figure 17.
- Install the pressure relief valve with the discharge connection facing the ground. If necessary, connect a pipe (of the same size as the valve outlet) to the outlet and run it to a code appropriate place of discharge.
- Do not install any shut-off or restriction in this pressure relief discharge line.

PRESSURE RELIEF VALVE (NON-ASME MODELS ONLY)

- Some local building codes require a pressure relief valve for non-ASME pool/spa heaters. Install the pressure valve on the ¾" port located on the plastic header (See Figure 17).
- The recommended ¾" pressure relief valve has a discharge capacity greater than or equal to the Btu/hr input of the heater, and a pressure rating equal to or less than the working pressure. See the rating plate located inside the front access panel on the heater for the input rating and working pressure. If desired, order the pressure relief valve (CHXRLV1930).
- To install: Remove the factory-installed pipe plug and install the pressure relief valve using an appropriate amount of pipe thread sealant or Teflon tape on the threads. Install the pressure relief valve with the discharge connection facing the ground. If necessary, connect a pipe (of the same size as the valve outlet) to the outlet and run it to a code appropriate place of discharge. Do not install any shutoff or restriction in this pressure relief discharge line.

Figure 17: Drain and Pressure Relief Valve Locations

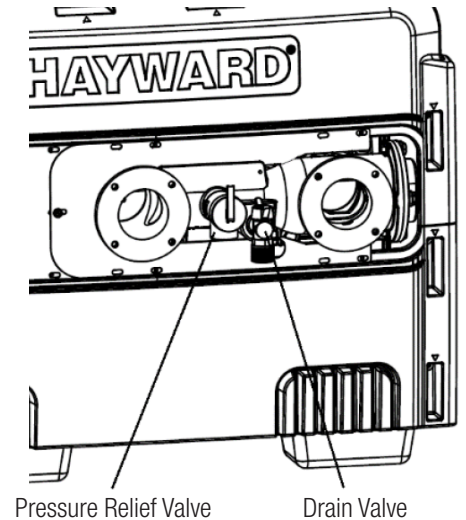

Electrical Connections

General Information

- Electrical Specifications: 120VAC only (HS135FDN/P) or 120/240VAC (HS150FDN/P - HS500FDN/P), 60Hz, 1-phase, 5.5A maximum current.
- It is recommended that circuit protection for the heater circuit be rated at 15 Amps.
- The heater is shipped wired for use with either 120VAC (HS135FDN/P) or 240VAC (HS150FDN/P - HS500FDN/P) field power supply.

All wiring connections to the heater must be made in accordance with the latest edition of the National Electrical Code ANSI/NFPA 70, unless local code requirements specify otherwise. In Canada, follow CSA C22.1 Canadian Electrical Code, Part 1. The heater must be electrically grounded and bonded in accordance with local codes or, in the absence of local codes, with National Electrical Code, ANSI/NFPA 70. Wiring connections must be made as shown in the wiring diagram found inside the heater cabinet and in Figure 2. The heater must also have an independent ground and bond connection. There is a ground lug inside the control box adjacent to the power connections per Figure 18 and a bonding lug on the side of the heater per Figure 9. Use a solid copper conductor, size No. 8 AWG (8.4 mm²) solid copper bonding wire or larger for bonding conductor. Run a continuous wire from external bonding lug to reinforcing rod or mesh. Connect to the grounding lug provided and to all metal parts of swimming pool or spa, and to all electrical equipment, metal piping (except gas piping), and conduit within 5 ft. (1.5 m) of inside walls of swimming pool or spa. **IMPORTANT** - Reference NEC codes for all wiring standards including, but not limited to, grounding, bonding and other general wiring procedures.

Hayward recommends the use of a sacrificial anode(s). Sacrificial anodes provide protection to the heat exchanger against galvanic corrosion when properly installed. Sacrificial anodes should be regularly inspected and replaced before the end of their useful life.

 **WARNING** – Risk of Electric Shock. Review all safety information provided in this manual prior to servicing. Always disconnect power circuit before servicing. This heater contains wiring that carries high voltage. Contact with these wires could result in death or personal injury.

The heater may be installed with the electrical service and optional remote control wiring entering the heater cabinet on either the left side junction box or right side using the floating junction box. There are (4) openings for electrical entry. The junction box must be used for field power wiring. Plug any unused openings with the supplied caps. The power connections are to be made to the supplied wires inside the junction box (See Figure 18) using field supplied wire nuts. All connections are to be stored within junction box attached to side panel.

Figure 18: Junction Box Connections

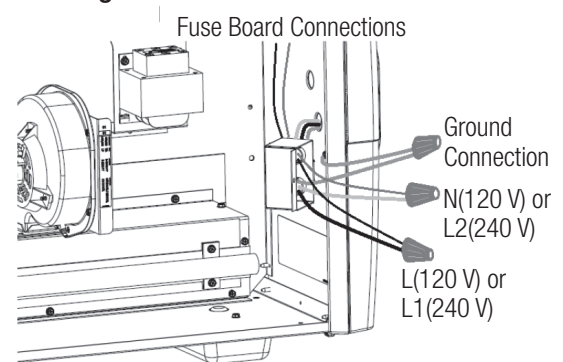



Input Power Wiring

To convert the heater to 120 VAC, 60 Hz operation, remove the 240 VAC voltage selector jumper from the ignition control board and replace it with the 120 VAC jumper. These jumpers are tie-wrapped together and are located on the fuse board. See the "Wiring Connection Diagrams" section on pages 9-10 for location of the fuse board as well as the input power wiring connections.

Remote Control Wiring

This heater can be remotely controlled in one the following manners:

- A 2-wire open/close connection to a supported pool control that turns the heater on when water temperature is below the control's setpoint.
- A 3-wire open/close connection to a supported pool control that selects the heater mode (Pool/Spa).
- A 3-wire serial "smart" connection to a supported Hayward Omni automation control that communicates with the heater and remotely controls all functions.

IMPORTANT: Before attempting to connect remote control wiring, turn off electrical power at the circuit breaker.

2-Wire Remote Control Connection

Refer to your pool control's manual for wiring information. Connect the appropriate wires from the pool control heater output to the factory harness ORANGE wire ("POOL") and WHITE wire ("COM").

3-Wire Remote Control Connection

Refer to your pool control's manual for wiring information. Connect the appropriate wires from the pool control heater output to the factory harness ORANGE wire ("POOL"), RED wire ("SPA") and WHITE wire ("COM").

To configure the heater for 2-wire or 3-wire remote thermostat control, refer to the "Remote Control Operation" section on page 29.

3-Wire Smart Connection To Hayward Omni Controls

Your heater can communicate with and be controlled by Hayward Omni automation controls including OmniLogic®, OmniPL®, OmniHub® and S3 Omni®. Controls must be using the minimum firmware revision R1.0.0 To determine the firmware revision in your control, consult your model's installation manual, which can be found at www.hayward.com.

To connect you heater to an Hayward Omni control, a 3 conductor serial connection must be made from the Omni control's low-speed bus screw terminal block to the heater's automation control terminal block, Refer to the installation manual for your Omni control to locate the low speed bus and determine which terminals to use. You can also refer to the numbers printed next to the terminal block on the control circuit board. Connect the supplied cable to the heater as shown below. If a longer run is required, connection wire must be rated for a minimum of 300V and may be up to 200ft in length. For all controls; wire terminals "2" to "2", "3" to "3" and "4" to "4". Terminal "1" is not used.

An example of a Hayward OmniLogic connected to the smart heater is shown below.

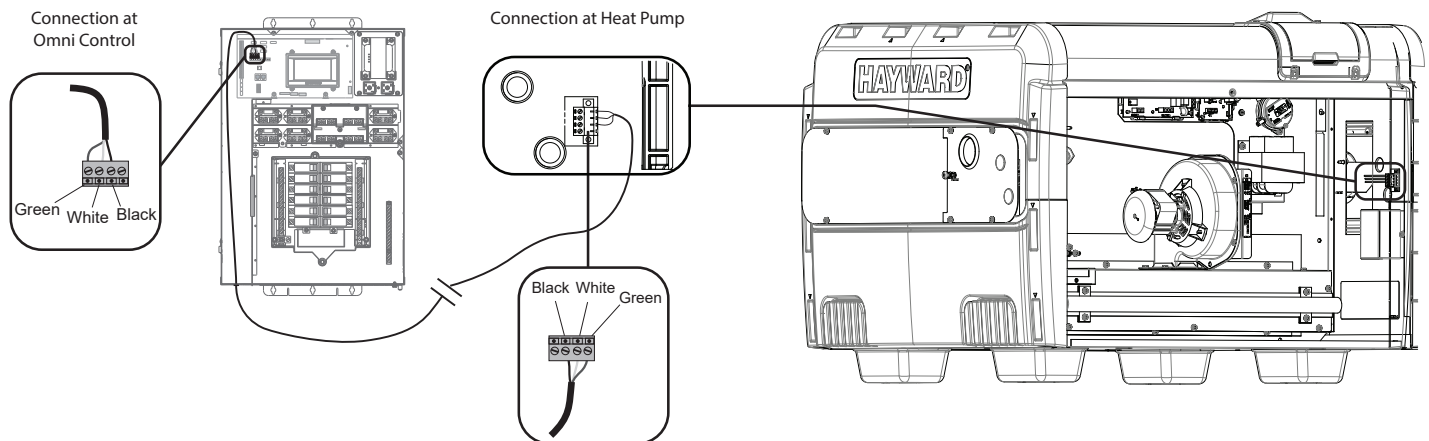

To configure the heater for 3-wire remote thermostat control using an Omni control, refer to the "Remote Control Operation" section on page 29.

Configuration and Operation

Operation Overview

The heater is equipped with a control system that automatically monitors the “Pool” and “Spa” temperature setpoints and control devices. When heat is needed, the heater turns on the combustion air blower, hot surface igniter and gas valve to light the burners and monitor the flames. Figure 1 provides a summary of heater components and their locations.

- Some procedures will require the heater to be operating.
- The full lighting and shutdown instructions are included in this manual and on the lighting and operating label affixed to the inside of the front access panel of the heater.
- Water must be flowing through the heater during any operation.
- Check that the pump is operating and the system is filled with water and purged of all air prior to starting the heater.

The temperature settings for both “SPA” and “POOL” modes are initially set at the factory to 65°F. The minimum allowed settings for “SPA” and “POOL” modes are both 65°F. The maximum allowed settings for “SPA” and “POOL” modes are adjustable up to 104°F. See “Standalone Operation” for instructions on adjusting the temperature setpoint.

Display User Interface Overview

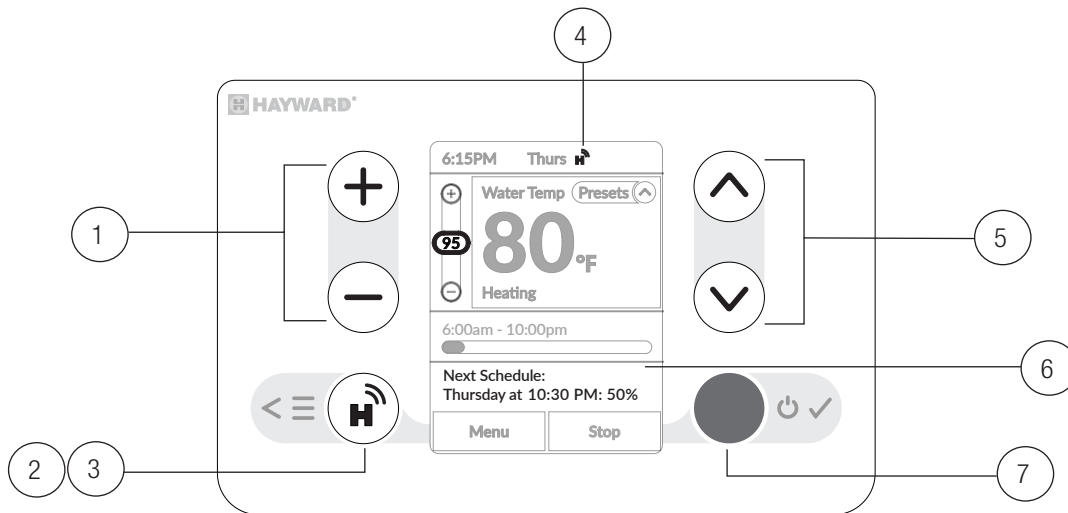

1. **Change Temperature:** Press "+" or "-" buttons to increase or decrease water temperature.
2. **Menu:** Press button to access the menu options. See "Standalone Operation" section.
3. **OmniX Claiming:** Press button to claim heater with OmniX. See "OmniX Operation" section.
4. **Configured through OmniX:** Icon displays when connected to the OmniX app. See "OmniX Operation" section.
5. **Navigation:** Use Up or Down arrows to navigate through display options.
6. **Status Messages:** Any status messages will display here.
7. **Start/Stop Heater:** Press button to start and stop heater operation.

Operation Modes

Operation Mode	Description
Standalone	The heater is controlled with the built-in display keypad (Universal Display).
OmniX	The heater is controlled using the OmniX mobile app.
2 or 3 Wire Remote Control	The heater is controlled remotely using a 2-wire or 3-wire On/Off connection. This is typically to a remote automation control that senses pool temperatures.
Omni Remote Control	The heater is controlled by a Hayward Omni control using a 3-wire serial communication connection.



Standalone Operation

Use the Universal Display to operate your pump with or without OmniX or remote control connections.

Press the “H” button on the display to enter the Menu panel.

- **Presets:** Create, modify, and start preset modes for pool temperature and duration.
- **Schedules:** Create, manage, edit schedules.
- **Settings:** Access Heater, General, Display, and Remote Control settings.
- **Diagnostics:** View errors, events, and heater status.
- **Equipment Info:** View model, firmware, and HUA info.
- **Legal Info:** View legal info, including FCC and IC Regulatory info.

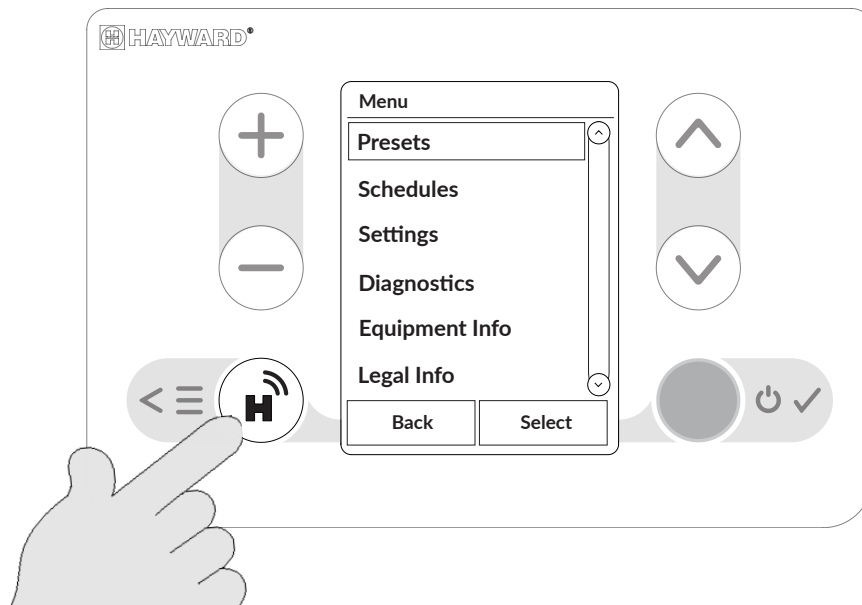

OmniX Operation

The OmniX app allows you to control your heater from the convenience of a mobile device. With the addition of a Hayward OmniX Gateway, OmniX equipment can be controlled beyond Bluetooth® wireless technology range and away from home.

Claiming Heater with Bluetooth® Wireless Technology

1. Scan the QR code and download the OmniX app from your mobile app store.
2. Enable Bluetooth on your mobile device.
3. Create or log in to an account in the OmniX app. You may use an existing Hayward OmniLogic account.
4. Apply power to the heater and press the “H” button on the display once. The display will show the “H” icon in gray, indicating that the heater is ready to be claimed.
5. Create a new site or connect to an existing OmniX site by following the instructions in the OmniX app. It is recommended to select the heater temperature sensor during site setup.
6. Claim and configure the heater by following the instructions on the OmniX app. Once claimed, the “H” icon on the display screen will become solid black.

Scan the QR Code below to download the OmniX App



OmniX Gateway Connection

Once you claim the heater, you can configure and control it using the OmniX app within the typical Bluetooth range of your mobile device. To control the heater remotely through the web, you must purchase the Hayward OmniX Gateway (W3GATEWAYX1) and add it to your home's network. Once added, the Gateway will act as a bridge between your mobile device and all Hayward internet-enabled equipment within your home network.

Control Equipment from the OmniX App

Note that the OmniX app will have the same function capabilities whether you are connected via Bluetooth or through the web using a Hayward Gateway. Refer to the following information when using the app:

Home Page

- 1 **OmniX Gateway** - If a Hayward OmniX Gateway (W3GATEWAYX1) is installed, this tile will provide access to Gateway settings. The OmniX Gateway provides internet connectivity for remote app control of OmniX Equipment.
- 2 **Body of Water** - Access settings for the Body of Water.
- 3 **Control Tiles** - Access Equipment control page (see below).
- 4 **Home Page** - Shortcut to Home page.
- 5 **Schedule** - Shortcut to Schedules page.
- 6 **Messages** - Shortcut to Messages (Alerts and Notifications).
- 7 **Menu** - Access to:
 - Site Settings
 - Select Site
 - Create Site
 - Service Mode
 - About
 - Help
 - Account
 - Logout

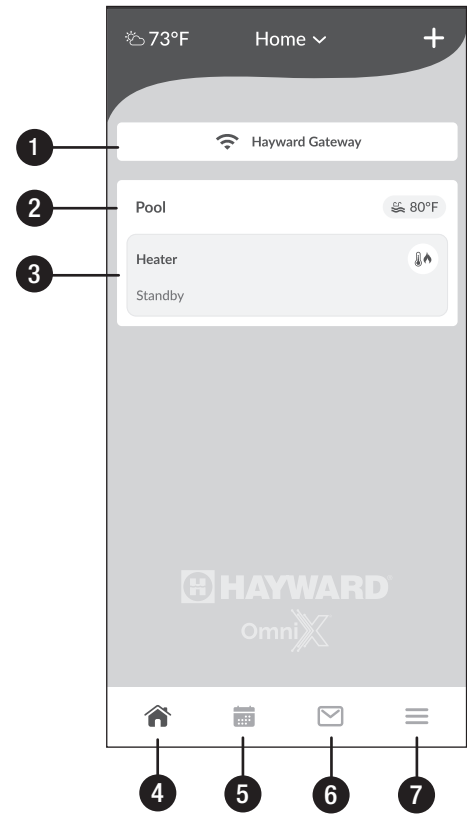

Equipment Page

- 1 **Status** - View operating state.
- 2 **Temperature Slider** - Adjust temperature with custom temperature control slider.
- 4 **Settings** - View Diagnostics, History and Equipment Settings (see next page).
- 5 **Countdown Timer** - Set custom countdown timers.
- 6 **Schedules** - Create, delete and modify schedules.
- 7 **Equipment Toggle** - Enable and disable heater operation.
- 8 **Network** - View method and quality of equipment network.
- 9 **Schedule Toggle** - Enable/Disable schedules.

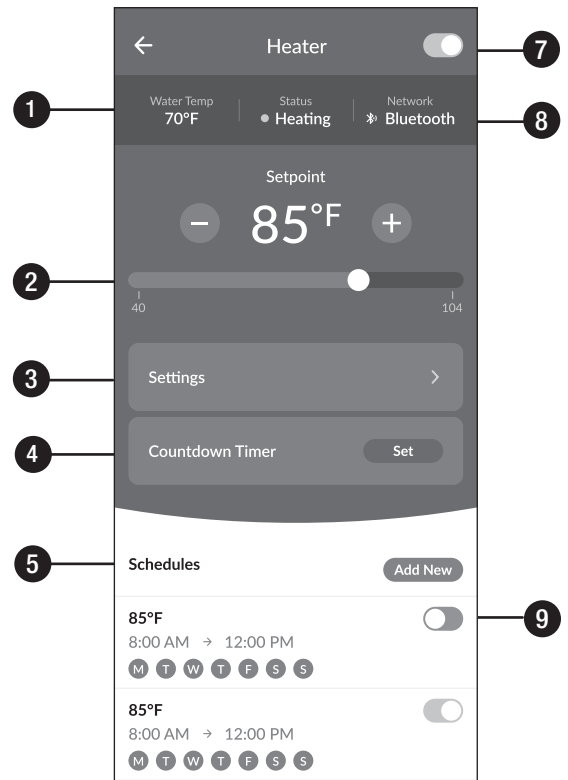

Settings Page

- 1 **Equipment Info** - View detailed heater information.
- 2 **Diagnostics** - View heater operating parameters.
- 3 **History** - View past diagnostic information.
- 4 **Configuration** - Modify heater configuration settings (see below).
- 5 **Delete Equipment** - Delete piece of equipment from the OmniX app. The equipment must be reset and reclaimed to regain control through the OmniX app. See instructions for resetting and claiming the device.

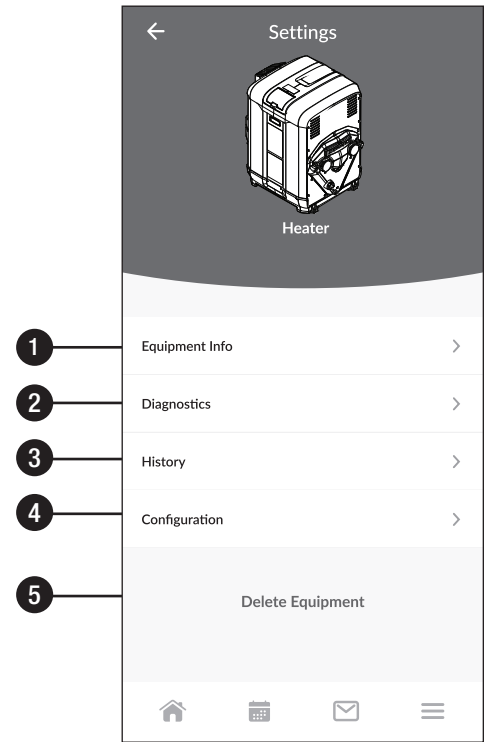

Configuration Page

- 1 **Heater/Chiller Name** - Edit heater name.
- 2 **Priority & Duration** - Set order and duration in which equipment will start heating/cooling.
- 3 **Extend Pump Runtime** - Enable pump to continue running beyond the scheduled run time until desired temperature is reached.

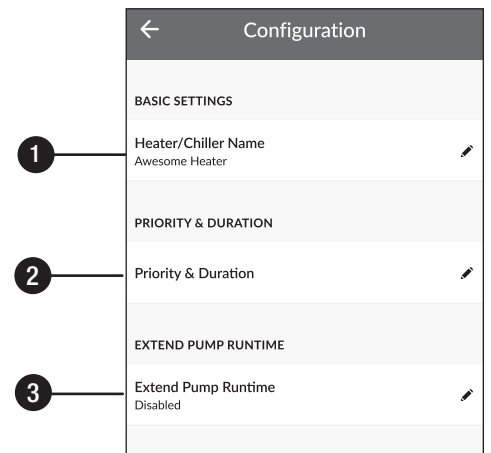



Remote Control Operation

2-Wire Remote Control

To configure the heater for 2-wire remote thermostat control, follow the instruction below. Refer to your control's manual for configuration and operation instructions.

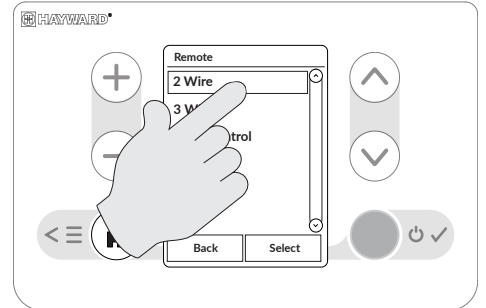
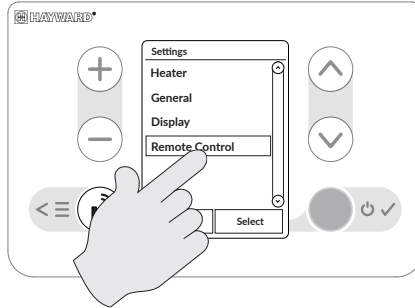
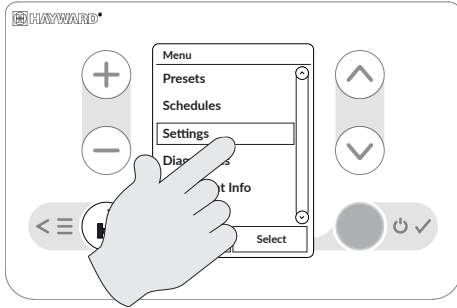

3-Wire Remote Control

To configure the heater for 3-wire remote mode control, follow the instructions below.

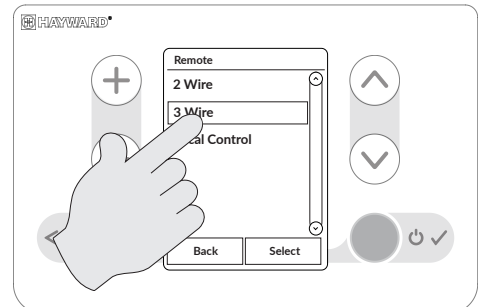
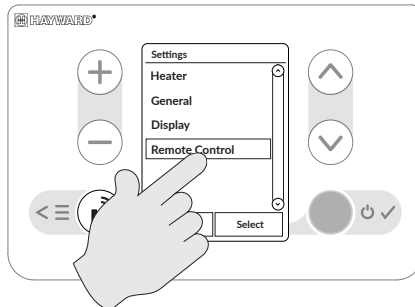
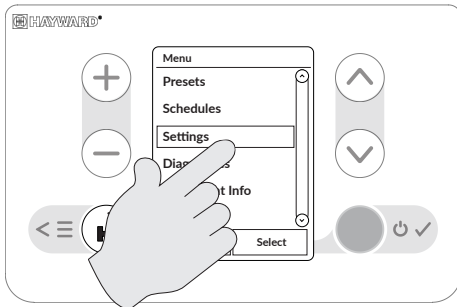

3-Wire Smart Connection to Omni Automation

To configure the heater for 3-wire smart Omni automation, make a three conductor serial connection from the Omni control's low-speed bus screw terminal block to the heater's automation control terminal block (See page 24).

The heater's Hayward Unique Address (HUA) shows on the display home screen when connected to a Hayward automation pool controller as shown below. Use the HUA to identify the heater when configuring your Omni control for heater operation. Refer to your control's manual for configuration and operation information. Manuals can be found at www.hayward.com.

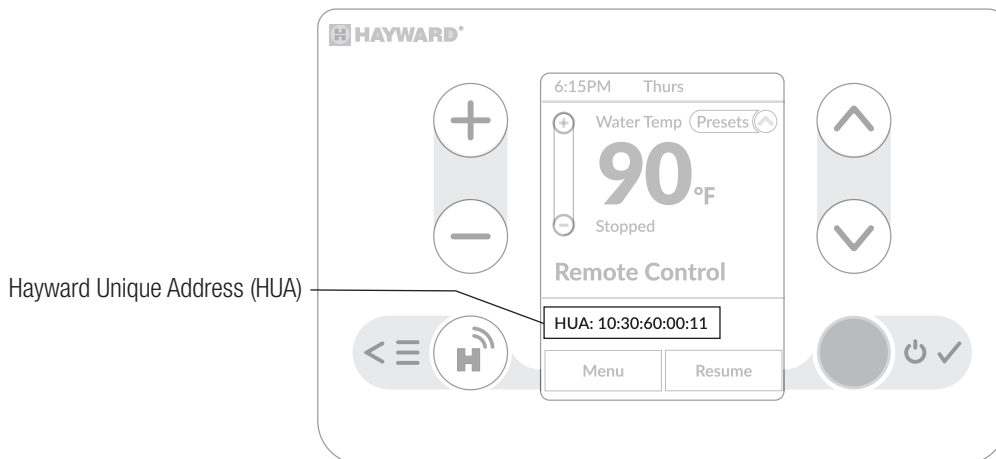



Heater Operation

If the heater does not operate as expected, consult the Troubleshooting section for additional information.

NORMAL OPERATION FOR POOL & SPA MODES: The control continually compares the water temperature with the setpoint and the high limit temperature. When the sensed water temperature is more than 1°F below the setpoint, a call for heat is generated and a heating cycle is initiated.

1. The control checks the differential pressure switch for open contacts and then energizes the blower. After the blower is energized, the contacts are checked again to ensure they are closed and the 30 sec. pre-purge timer is started.
2. The control energizes the igniter during the pre-purge cycle and allows it to reach ignition temperature, approximately 20 seconds.
3. The control energizes the gas valve to permit the flow of gas for the 4 sec. trial for ignition and monitors flame current.
4. The igniter is turned off when flame current is sensed or when the trial for ignition is completed.

When the thermostat is satisfied and the call for heat ends, the control immediately de-energizes the gas valve and flame extinguishes. The control operates the blower an additional 30 seconds as a post-purge.

Gas Testing

GAS LINE TESTING: The appliance and its gas connection must be leak tested before placing the appliance in operation. The heater must be isolated from the gas supply piping system by closing its individual manual shutoff valve during any pressure testing of the gas supply piping system at test pressure equal to or less than ½ psig (3.45 kPa). Gas supply line must be capped when not connected. After pressure testing, reconnect the gas piping to the gas valve. Turn gas supply "ON" and test all pipe and tubing joints for leaks. Use a soap and water solution.

⚠ WARNING – Explosive Hazard. The use of an open flame to check for gas leaks could cause an explosion resulting in severe injury and/or death. Shut off gas and fix even the smallest leak right away. Be sure to leak test the heater gas manifold fittings using the above procedure once the heater is in operation.

GAS PRESSURE TESTING: The following gas pressure requirements are important for the operation of the burners in gas heaters. Improper gas pressure or gas volume may create the following conditions:

1. Flame burns totally yellow.
2. Flame lift off burner.
3. Heat exchanger soot's up. The gas pressure regulator on all heaters is preset at the factory, but the setting should be verified by the installer to ensure proper operation.

⚠ NOTICE – If inlet gas pressure is inadequate, check for undersize piping between the gas meter and the heater or for a low-capacity gas meter (See "Gas Supply" section on page 18).

Figure 20: Lighting and Operating Instructions Label
(This label is also located on the inside surface of the heater cabinet)

FOR YOUR SAFETY READ BEFORE LIGHTING		POUR VOTRE SÉCURITÉ LIRE AVANT L'ALLUMAGE	
<p>WARNING: If you do not follow these instructions exactly, a fire or explosion may result causing property damage, personal injury, or loss of life.</p> <p>A. This appliance does not have a pilot. It is equipped with an ignition device which automatically lights the burners. Do not try to light the burners by hand.</p> <p>B. BEFORE LIGHTING smell all around the appliance area for gas. Be sure to smell next to the floor because some gas is heavier than air and will settle on the floor.</p> <p>WHAT TO DO IF YOU SMELL GAS:</p> <ul style="list-style-type: none"> * Do not try to light any appliances. * Do not touch any electric switch; do not use any phone in your building. * Immediately call your gas supplier from a neighbor's phone. Follow the gas supplier's instructions. * If you cannot reach your gas supplier, call the fire department. 		<p>AVERTISSEMENT: Si vous ne suivez pas exactement ces instructions, un incendie ou une explosion pourrait survenir et causer des dommages à la propriété, des blessures corporelles ou la perte de la vie.</p> <p>A. Cet appareil n'a pas de pilote. Un mécanisme d'allumage automatique pour les brûleurs.</p> <p>B. AVANT L'ALLUMAGE, sentir tout autour de l'appareil pour détecter d'éventuelles odeurs de gaz.</p> <p>C. Utiliser uniquement les mains pour actionner les boutons de commande du gaz. Ne jamais utiliser d'outils. Si le bouton ne s'enfonçe pas ou ne se tourne pas à la main, ne pas essayer de le réparer. Appeler un technicien qualifié. L'utilisation de la force ou une tentative de réparation pourrait causer un incendie ou une explosion.</p> <p>D. Ne pas utiliser cet appareil si une des composantes a été immergée dans l'eau. Appeler immédiatement un technicien qualifié pour vérifier l'appareil et remplacer toute composante du système de commande ou de gaz qui aurait été immergée dans l'eau.</p> <p>E. Si le système surchauffait ou si le gaz refusait de se fermer, placer le robinet d'arrêt manuel de gaz de l'appareil en position "FERME" (OFF).</p>	
<p>C. Use only your hand to turn the gas control knob. Never use tools. If the knob will not turn by hand, don't try to repair it; call a qualified service technician. Force or attempted repair may result in a fire or explosion.</p> <p>D. Do not use this appliance if any part has been under water. Immediately call a qualified service technician to inspect the appliance and to replace any part of the control system and any gas control which has been under water.</p> <p>E. Should over-heating occur, or the gas supply fails to shut off, turn off manual gas valve to the appliance.</p>		<p>S'assurer de sentir près du plancher parce que le gaz plus lourds que l'air, se concentrent au niveau du plancher.</p> <p>QUE FAIRE EN PRÉSENCE D'ODEURS DE GAZ:</p> <ul style="list-style-type: none"> * Ne pas essayer d'allumer l'appareil. * Ne pas toucher à un commutateur électrique; ne pas utiliser le téléphone dans la maison. * Appeler immédiatement fournisseur de gaz chez un voisin. Suivre les instructions du fournisseur de gaz. * Si le fournisseur ne peut pas être atteint, appeler le service des incendies. 	
OPERATING INSTRUCTIONS		INSTRUCTIONS D'ALLUMAGE	
<p>1. STOP! Read the safety information on this label.</p> <p>2. Change the "MODE" on the control panel to "STANDBY".</p> <p>3. Remove the heater's front access panel.</p> <p>4. This appliance is equipped with an ignition device which automatically lights the burners. Do not try to light the burners by hand.</p> <p>5. Move the gas control switch to "OFF".</p> <p>GAS CONTROL SWITCH SHOWN IN "OFF" POSITION</p> <p>6. Wait five (5) minutes to clear out any gas. If you then smell gas, STOP! Follow "B" in the safety</p>		<p>1. STOP! Lire les consignes de sécurité sur cette étiquette.</p> <p>2. Changer le MODE du tableau de commande à STANDBY.</p> <p>3. Retirer le panneau d'accès avant de l'appareil de chauffage.</p> <p>4. Cet appareil est pourvu d'un dispositif d'allumage qui allume automatiquement les brûleurs. Ne pas tenter d'allumer manuellement les brûleurs.</p> <p>5. Déplacer l'interrupteur de commande de gaz sur OFF (fermé).</p> <p>COMMUTATEUR DE COMMANDE DE GAZ MONTRÉ EN POSITION "FERME" (OFF)</p> <p>6. Attendre cinq (5) minutes que tout gaz se dissipe.</p>	
<p>7. Move gas control switch to "ON".</p> <p>8. Replace the heater's front access panel.</p> <p>9. Set the "MODE" on the control panel to "SPA" or "POOL".</p> <p>10. Set the setpoint temperature on the control panel to the desired setting.</p> <p>11. If the appliance does not operate, repeat steps 2 thru 10. If the appliance still does not operate, follow instructions "TO TURN OFF GAS TO APPLIANCE" and call your service technician or gas supplier.</p>		<p>7. Passer à l'étape suivante en l'absence d'odeur de gaz sur ON (OUVERT).</p> <p>8. Remplacer le panneau d'accès avant de l'appareil de chauffage.</p> <p>9. Régler le MODE du tableau de commande à SPA ou à POOL.</p> <p>10. Établir la valeur de réglage sur le tableau de commande à la température désirée.</p> <p>11. Si l'appareil ne fonctionne pas, répéter les étapes 2 à 10. Si l'appareil refuse toujours de "FERME" fonctionner, dissipe. Suivre les instructions Pour tourner le gaz à l'appareil et appeler votre technicien de service ou votre fournisseur.</p>	
TO TURN OFF GAS TO APPLIANCE		POUR FERMER LE GAZ SUR L'APPAREIL	
<p>1. Change the "MODE" on the control panel to "STANDBY".</p> <p>2. Remove the heater's front access panel.</p> <p>3. Move the gas control switch to "OFF".</p> <p>4. Replace the heater's front access panel.</p>		<p>1. Changer le MODE du tableau de commande à STANDBY.</p> <p>2. Retirer le panneau d'accès avant de l'appareil de chauffage.</p> <p>3. Déplacer l'interrupteur de commande de gaz sur OFF (fermé).</p> <p>4. Remplacer le panneau d'accès avant de l'appareil de chauffage.</p>	

GAS PRESSURE TEST PROCEDURE: Follow the lighting instructions provided on the unit or in Figure 20. Refer to Figure 1 for the location of the gas control. See Figure 21 for pressure regulation adjustment used in this procedure. Note that even though the valves look different, the required pressure taps and regulation adjustment screws are present on every gas valve.

1. Obtain the necessary equipment: Two (2) manometers to read pressure in inches of water column, Two (2) 1/8" NPT pipe barbed fitting, silicon or EPDM hose to fit on barb fittings, 3/16" hex wrench, 7/16 open end wrench, and medium flat screw driver.
 2. Turn off gas supply to heater. Access the gas valve and remove the 1/8" plugs from the gas valve inlet pressure and manifold pressure taps and install the barb fittings into the tap openings.
 3. Securely connect the hoses and manometers to the barb fittings. Make sure the manometers have ample range and accuracy to properly read the gas inlet pressure and manifold pressure per Table 15.
 4. Turn on gas and water to heater and start the heater following the lighting and operating instructions on the label affixed inside the front access panel. If there is more than one pool/spa heater connected to the gas supply line, turn each of those appliances "ON" while testing the heater.
 5. Take pressure readings with the heater(s) running, the pressure values should agree with those in Table 15. If the pressures are within the stated ranges, then no further adjustment is needed. If the manifold gas pressure does not meet the values in Table 15, the gas valve regulator must be adjusted.
 6. To adjust the gas valve regulator, perform the following:
 - i. Remove the screw cap over the regulator adjustment screw (See Figure 20).
 - ii. Turn the inner regulator adjustment screw clockwise to increase pressure and counterclockwise to decrease pressure as required.
 - iii. Replace the screw cap over the regulator adjustment screw.
 - iv. Cycle the heater on/off multiple times and repeat measurements to ensure regulation springs are set.
- ⚠ NOTICE** – If adjusting the gas valve regulator does not achieve proper pressures, the installer must contact the gas supplier and request that the inlet pressure to the heater(s) be provided to within the gas pressure range listed.
7. Turn the gas supply to the heater off and remove the barb fittings. Replace the original 1/8" pipe plugs and connect tubing as shipped from the factory. Turn on gas and water to heater and start the heater to check for gas leaks.

Table 15: Required Gas & Air Pressures (inwc)		
Measurement	Natural	Propane
Manifold Pressure	+1.80 to 2.20	+6.80 to 7.00
Inlet Pressure, Minimum	+4.50	+10.00
Inlet Pressure, Maximum	+10.50	+13.00
Blower Vacuum, Minimum	-0.50	-0.50
Vent Pressure, (Models 150-400) Maximum	+0.45	+0.45
Vent Pressure, (Model 500) Maximum	+0.30	+0.30

⚠ WARNING – Explosion Hazard. Do not remove the measurement tap screws with the valve in the "ON" position and gas supplied to heater. No gas pressure must be present when the taps are open to atmosphere. Removal of the taps screws or barb fittings with gas present could cause an explosion resulting in severe injury and/or death.

⚠ WARNING – Explosion Hazard. Gas pressures in excess of those listed in Table 15 could cause a gas leak or diaphragm rupture. Gas leakage could cause an explosion resulting in severe injury or death.

Figure 21: Gas Valves

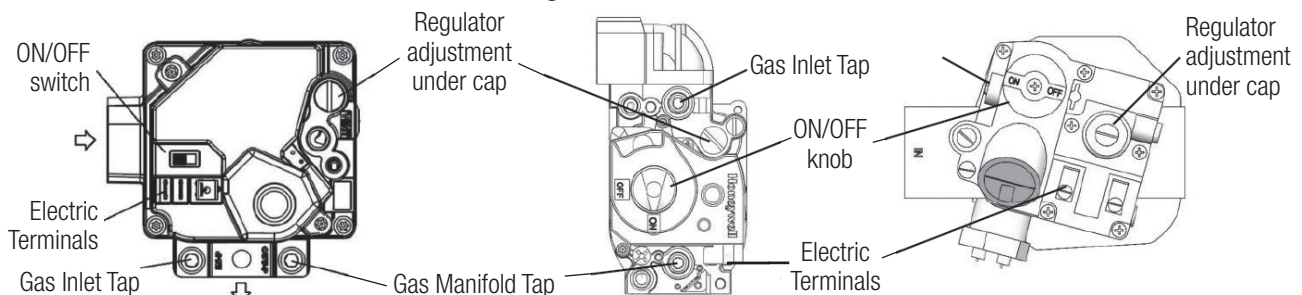

For all valves, adjust regulator pressure by removing the screw cap and turning the adjustment screw clock wise for increase in pressure and counterclockwise for decrease in pressure



Water Pressure Switch Test and Adjustment Procedure

The pressure switch is preset at the factory for most typical deck level installations. When the heater is located above or below the level of the pool or spa, the pressure switch will require adjustment to compensate for the change in static pressure. The following procedure is recommended when the switch needs adjustment and/or is replaced:

1. Be sure the filter is clean before making any adjustment.
2. Turn "ON" the filter pump and ensure all air is out of the water lines, and ensure water flow rate is at least the rated minimum (See Table 1).
3. Turn "ON" the heater and adjust the temperature control to create a call for heat.
4. Adjust the pressure switch as needed:
 - a. For installations with heater ABOVE water level: If the heater does not light, adjust the pressure switch by turning the adjustment knob on the pressure switch counter-clockwise until the heater lights. Turning the adjustment knob counterclockwise decreases the pressure needed to close the switch (Figure 22).
 - b. For installations with heater BELOW water level: Turn the adjustment knob on the pressure switch clockwise, until the heater turns off, then turn the knob $\frac{1}{4}$ turn counter-clockwise, so that the heater turns back on. Turning the adjustment knob clockwise increases the pressure needed to close the switch.
5. Check the function of the pressure switch by turning the filter pump on and off several times and confirming that the heater turns off immediately when the pump is turned off. Never allow the heater to operate with less than the minimum rated water flow rate.

Figure 22: Water Pressure Switch

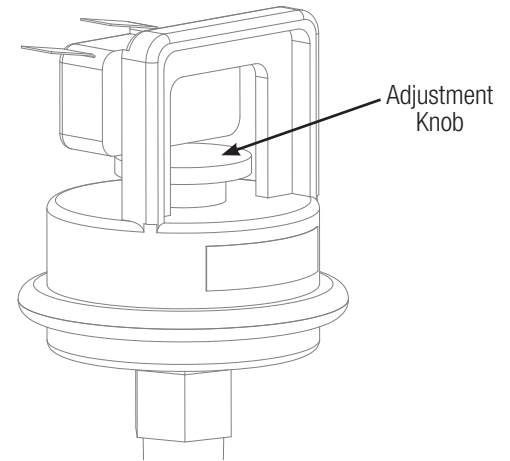

TWO-SPEED PUMP: In a few cases the pressure from a two-speed pump is below the 1-pound minimum required to operate the water pressure switch on the heater. This is apparent when the pressure switch cannot be further adjusted. In these cases the pump must be run at high speed to operate the heater. If the pump and piping arrangement are such that the required 1-pound minimum pressure cannot be obtained, do not attempt to operate the heater. Correct the installation.

▲ NOTICE – Heater installation, checkout, and start-up should now be completed. BE SURE to leave this manual with the pool owner.

Maintenance and Service

Periodic Inspection

The heater is designed and built for long performance life when installed and operated according to the manufacturer's directions. Regular inspection by qualified service personnel is recommended to keep the heater working properly. The following inspection points are suggested to help maximize heater life.

1. Periodically check the venting on outdoor heaters. The heater's venting areas (the louvered top panel) must never be obstructed in any way and minimum clearances must be observed to prevent restriction of combustion and ventilation air. Remember that shrubs grow and in time may obstruct the heater venting areas.
2. Check the venting of indoor heaters for looseness and possible leaks. Keep all openings for combustion and ventilation air clear and unobstructed.
3. Keep the entire pool heater area clean and free of all debris, combustible materials, gasoline, and other flammable vapors and liquids. Remove any leaves or paper from around the heater.
4. Do not store chlorine, other pool chemicals, or other corrosives in the vicinity of the heater.
5. If the heater is operating on propane gas, the tank must not fall below 30% full or damage to the heater may occur. Manufacturer will not be responsible for heaters that soot up due to improper gas level in the tank resulting in inadequate gas volume.
6. If another appliance is added to the gas line at a later date, consult the local gas company to be sure the gas line will have the capacity to supply both units at full input rating at the same time.
7. Do not use the heater if any part has been under water. Contact a qualified service technician to inspect the entire heater and replace any part of the control system or gas valve that was under water. If heater has been totally submerged in water it must be removed and the entire heater must be replaced.
8. An inspection program is a good preventative maintenance measure. Keep this manual in a safe place for future reference for yourself as well as for a service technician to consult when inspecting or servicing the heater. Any additional inspection procedures are to be performed by a qualified service technician.



Water Chemistry

⚠ WARNING - Water Chemistry. Failure to maintain proper water chemistry may cause premature heat exchanger damage or failure

The heat exchanger in your pool heater is made from the highest quality of copper and nickel (Cupronickel) materials. This premium material and the exacting processes used to manufacture the heat exchanger is state of the art in pool heater design and manufacture. However, the heat exchanger must be protected from damaging or corrosive chemicals, insufficient water flow or improperly balanced water chemistry. Heat exchanger damage or failure resulting from improper flow, improperly balanced pool water or the improper addition of sanitizer into the water is NOT covered under the terms of the warranty. Follow the guidelines below and in Table 16 to help prevent premature damage to or failure of your heater and heat exchanger.

- 1. WATER FLOW THROUGH HEATER:** Water must be flowing through the heater at the minimum rated flow rate during operation. Check that the pump is operating and the system is filled with water and purged of all air prior to starting the heater. The minimum flow rates are listed in the "Specifications" section. Some installations may require an adjustment to the water pressure switch for proper low-flow protection. Test your system and if necessary, adjust the water pressure switch as described in the "Water Pressure Switch Test and Adjustment Procedure" section.
- 2. WATER CHEMISTRY:** The chemistry balance and mineral content of swimming pool and spa water changes rapidly due to the addition of sanitizing chemicals, user loads, exposed rain, runoff, and the amount of sun. Improper chemistry (see Table 16) balance and mineral content can cause scaling and deposits to form on pool walls, in the filtration system, in the heat exchanger tubes, and additionally can promote corrosive action to all metals in the water path. Changing spa water regularly and maintaining the correct chemical balance in your pool/spa will keep the pool/spa safe and sanitary and will help heat exchanger longevity. Use a four-way pool/spa water test kit to check your water frequently (at least weekly). Use the following guidelines to help maintain proper water chemistry:

Table 16: Water Chemistry			
Chemical	Recommended Level	Effect of Low Levels	Effect of High Levels
Chlorine	1 to 3 ppm	Hazy water, algae growth, bacteria causing infections	Swimmer irritation, bleaching of clothes/hair, corrosive to heat exchanger
Bromine	2 to 4 ppm		
pH	7.4 to 7.6 ppm	Corrosive to heat exchanger, swimmer irritation	Cloudy water, scaling of heat exchanger, reduced sanitizer effectiveness
Total Alkalinity	80 to 120 ppm	Corrosive to heat exchanger, large fluctuations in pH	Scaling of heat exchanger
Calcium Hardness	200 to 400 ppm	Corrosive to heat exchanger	Scaling of heat exchanger
Salt	2700 to 5000 ppm	Poor salt chlorinator performance	Corrosive to heat exchanger

- 3. SKIMMER CHLORINATION:** Placing chlorine or bromine tablets directly into the skimmer may result in high chemical concentrations flowing through the heater. DO NOT place chlorine or bromine tablets in the skimmer.
- 4. CHLORINATOR INSTALLATION:** Chlorinators must be installed downstream of the heater, and a check valve must be installed between the heater and chlorinator to prevent high chemical concentrations from back flowing into the heater. Make sure your piping arrangement meets the chlorinator installation requirements.
- 5. BYPASS VALVE:** Bypass heater until water chemistry is properly balanced, so that corrosive and potentially damaging water will not flow through the heater and therefore the heat exchanger. Close the bypass valve once the water is properly balanced.

⚠ WARNING – Failure to close the bypass valve when attempting to operate the heater will result in extensive damage to the heat exchanger.

Ensure water flow through the heater is restored before operating the heater. A bypass feature is also advantageous for service needs and for the ability to remove the heater from the water path when not heating.

Winterization

In moderate climates, the heater can continue to operate during short-term cold spells. Do not use the heater to maintain the water temperature just above freezing or for freeze protection. Care must be taken to avoid freeze-up in the heater. When it is used during freezing weather, the pump must run continuously. The heater is not warranted against freeze-ups. In regions where freezing temperatures are encountered, all water must be drained from the heater when it is out of service to prevent damage to the heater and piping. Draining the heat exchanger is recommended as part of the season's shutdown procedures.

▲ NOTICE – A heater damaged by freezing is not covered under the manufacturer warranty.

DRAINING THE HEAT EXCHANGER: This procedure applies to installations where the heater is located higher than the pool water level. If it is necessary to drain a pool heater located below the pool water level, you must either partially drain the pool, or isolate the pool heater from the pool using valves, then follow these steps.

1. Set the heater to STANDBY mode using the keypad.
2. Turn the electricity to the heater OFF at the circuit breaker panel.
3. Turn the heater gas valve OFF using the knob or switch on the valve (see Figure 21).
4. Turn the heater's gas supply OFF at the main shut-off valve outside the heater cabinet.
5. Be sure the circulating pump is OFF.
6. On models with plastic headers, remove the plastic drain plug (see Figure 23). On models with bronze headers (ASME models), open the brass drain valve located on the header (see Figure 17).
7. Allow all water to drain from the heater.
8. On models with plastic headers, re-install the plastic drain plug. On models with bronze headers (ASME models), close the brass drain valve located on the header.

Spring Start-Up

This procedure should be performed annually to ready your heater for the upcoming season. In addition to the steps outlined below, it is recommended that a Periodic Inspection also be performed.

1. Inspect and clean the heater, being sure the heater is free of leaves and debris prior to startup.
2. Be sure inlet and outlet piping are properly attached to the heater and the drain valve is closed.
3. Turn the filtration system pump "ON" and allow the system to run long enough to purge all the air from the lines.
4. Turn the gas supply to the heater "ON".
5. Set the temperature control using the keypad to "POOL" or "SPA" and adjust the setpoint to the desired temperature setting.
6. If operating difficulties are encountered, contact a qualified service company for assistance.

Figure 23: Heat Exchanger Header

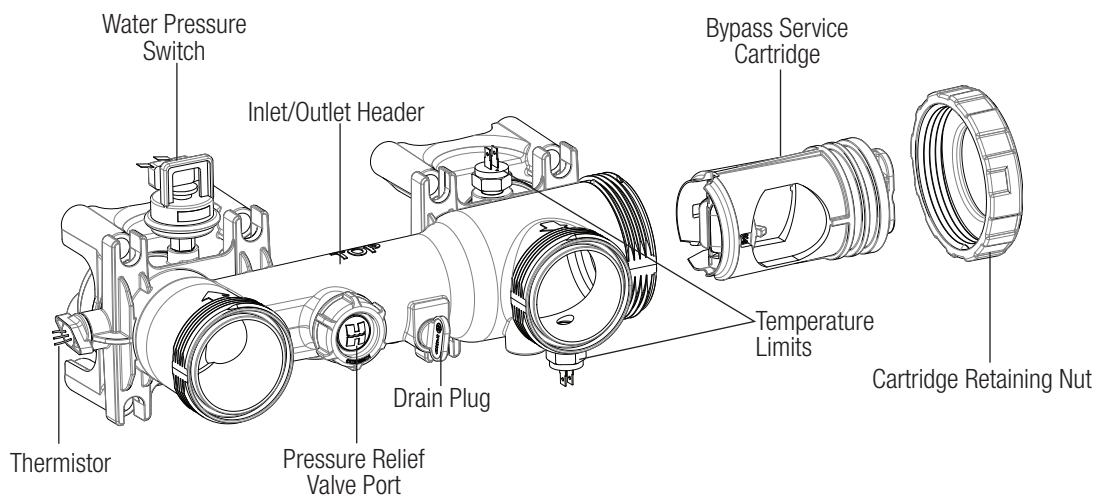



Component Service

⚠ WARNING – Only qualified service technicians, with appropriate test equipment, should be allowed to service the heater. All of the components that comprise the system have an effect on heater operation. Before proceeding with heater related troubleshooting tips, be certain that the pump is operating correctly, the filters and strainers are not blocked, the valves in the piping are properly positioned, and the time clocks are properly set.

⚠ WARNING – Failure to comply with the service instructions may result in equipment damage, fire, asphyxiation, or carbon monoxide poisoning. Exposure to products of incomplete combustion (carbon monoxide) can cause cancer and birth defects or other reproductive harm.

⚠ WARNING – Explosion Hazard. Do not attempt to repair broken or faulty components of this heater. Do not modify the heater or its components in any manner. To do so may result in a malfunction that could result in death, personal injury, or property damage. Check with the pool owner to see if any part of the heater has been under water. Replace any electrically operated component that has been under water.

The following service procedures are recommended to be performed as part of annual heater maintenance to ensure proper heater operation and long life.

HEAT EXCHANGER INSPECTION AND CLEANING: Remove the louvered exhaust cover panel and inspect the external surfaces of the heat exchanger for debris or soot accumulation. If heat exchanger needs cleaning perform the following procedure:

⚠ WARNING – Burn Hazard. Let heater cool before performing any disassembly or servicing of the heater. Wear proper PPE when servicing heater.

1. Turn pump, main gas valve and heater power “OFF”. Perform only DRY cleaning with heat exchanger in heater. WET cleaning requires that the heat exchanger be removed from heater.
2. For DRY cleaning remove debris by hand, soft-tipped brush or shop VAC.
3. For WET cleaning remove heat exchanger by following the “Reversible Water Connections” procedure found in the Water Piping section of this manual. Use a soft-tipped brush (such as a paint brush), to apply a degreaser to the entire heat exchanger surface (top and bottom). Allow the heat exchanger to sit for a period of time to allow the degreaser to loosen the debris. Wash the heat exchanger using a garden hose at a medium to low pressure setting. Ensure both the top and bottom surfaces are cleaned.
4. Check combustion chamber refractory is still in a single-piece casting with no cracks or holes. This evaluation can be performed with heat exchanger in place with additional lighting or with heat exchanger removed from unit. If combustion chamber refractory is damaged, the entire chamber must be replaced.
5. Re-assemble the heater by reversing the disassembly steps. Turn pump, main gas valve and heater power “ON”. Test fire heater.

⚠ NOTICE – Although the heat exchanger should be cleaned of soot and reinstalled, the fact that soot occurred should be investigated. It may indicate other problems such as: Insufficient air supply; Inadequate venting; High or low gas pressure; Blockage of burner tubes or orifices; Blockage of blower inlet; Low voltage supply causing blower to “spin” slower; Improper heater location / installation; Incorrect gas supply pipe size; Excessive water flow through heat exchanger; Or an LP tank below 30% full level.

BURNER INSPECTION AND CLEANING: With the heater “ON”, remove the front access panel and make a visual inspection of the main burners through the sight glass (see Figure 1) The main burner flames should be about 1” to 2” in height and should not “lift” off the burner ports (See Figure 24). A normal flame is blue, without yellow tips. Yellow tips or a totally yellow or “lazy” flame may be an indication of an incorrect fuel / air mixture. Check the heater for restrictions to the air supply, heat exchanger, vent system, burner body and/or gas orifices.

Figure 24: Burner Flame Characteristics

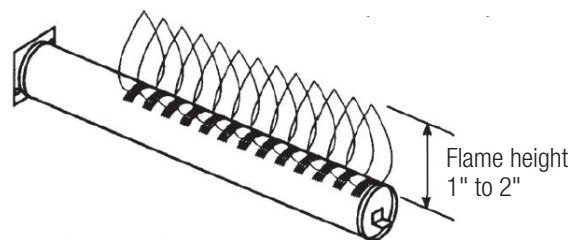



BURNER REMOVAL AND REPLACEMENT: Refer to Page 6, Figure 8, and Figure 1 as needed.

1. Turn pump, gas supply, and heater power "OFF". Turn gas valve knob "OFF".
2. Remove the front access panel.
3. Disconnect the union joint in the gas supply piping outside the heater cabinet.
4. Disconnect the wiring terminals from the gas valve and blower
5. Remove the gas manifold assembly. It is attached to the air box using (4) screws.
6. Remove the screws from the igniter access panel and pull it out of the way. Do not disconnect the wires.
7. Remove the air box cover. Do not remove the blower from the air box cover.
8. Remove the (2) screws securing each burner to the combustion chamber front.
9. Pull the burners straight out of the heater.
10. Reverse the above procedure to re-install the burners.
11. Turn the gas supply "ON". Use a soapy water solution to check for leaks. Bubbles forming indicate a leak.

⚠ WARNING - Explosion Hazard. The use of an open flame to check for gas leaks could cause an explosion resulting in severe injury and/or death.

12. Turn pump, gas valve knob and heater power "ON". Test fire heater by following the **GAS PRESSURE TEST PROCEDURE**.

GAS VALVE REPLACEMENT: Refer to Page 6, Figure 1 Figure 21 as needed.

1. Turn pump, gas supply, and heater power "OFF".
2. Disconnect the union joint in the gas supply piping outside the heater cabinet.
3. Remove the front access panel.
4. Disconnect the wiring terminals from the gas valve.
5. Remove the gas manifold assembly. It is attached to the air box using (4) screws.
6. Unscrew the gas valve from the gas manifold pipe.
7. Reassemble the gas manifold assembly using the new gas valve. Only use liquid pipe thread sealant on the male threads of the gas manifold pipe. Do not place pipe dope on the first two threads of any joint.
8. Reverse the above procedure to re-install the gas manifold. Turn pump, main gas, gas valve and heater power "ON". Test fire heater by following the GAS PRESSURE TEST PROCEDURE. Check for leaks using soap and water.

IGNITER REPLACEMENT: Refer to Page 6 and Figure 1 as needed.

1. Turn pump, gas supply, and heater power "OFF".
2. Remove the front access panel.
3. Disconnect the igniter wires from the ignition control board.
4. Remove the screws from the igniter access panel. Working from the underside of the panel, press the bushing out of the hole in the sheet metal panel.
5. Slide the igniter wires through the slot on the panel and pull the panel free.
6. Remove the (2) screws that secure the igniter.
7. Pull the igniter straight back until it is free of the combustion chamber refractory and out of the air box.
8. Replace the igniter and reverse the above procedure to reassemble unit.

FLAME SENSOR REPLACEMENT: Refer to Page 6 and Figure 1 as needed.

1. Turn pump, gas supply, and heater power "OFF".
2. Remove the front access panel (4 screws).
3. Disconnect the flame sensor wire from the ignition control board.
4. Remove the screws that secure the flame sensor to remove the sensor.
5. Replace the flame sensor and reverse the above procedure to reassemble unit.

BURNER ORIFICE REPLACEMENT: Refer to Page 6, Figure 1 as needed.

1. Turn pump, gas supply, and heater power "OFF".
2. Disconnect the union joint in the gas supply piping outside the heater cabinet.
3. Remove the front access panel.
4. Disconnect the wires from the terminals on the gas valve.
5. Remove the gas manifold assembly. It is attached to the air box using (4) screws.
6. Remove the orifices using a 7/16" wrench.
7. After cleaning or replacing orifices re-install into the gas manifold pipe being careful not to cross-thread or over tighten as a leak may result.

⚠ NOTICE – Do not enlarge orifice holes.

⚠ NOTICE – All replacement wiring must be replaced with manufacturer supplied replacement parts.



IGNITION CONTROL SYSTEM: The control system in this heater consists of four components (ignition control board, display board, fuse board and membrane keypad). The locations of these components are shown in Figure 1. The ignition control board functions as the heater's thermostat control, safety control system, and gas ignition and combustion monitoring system.

To remove/replace the ignition control board or the fuse board:

1. Turn pump, gas supply, and heater power OFF.
2. Remove the front access panel.
3. Disconnect all wires from the printed circuit board.
4. Detach the board from the sheet metal panel by compressing the plastic standoffs.
5. Replace the board and reverse the above procedure to reassemble unit.

BLOWER VACUUM SWITCH: The blower vacuum switch is a safety device that prevents the ignition sequence from continuing unless the blower is developing sufficient airflow for combustion. When the blower achieves sufficient airflow, the negative pressure created in the blower housing closes the contacts on the blower vacuum switch, indicating to the ignition control board that it is safe to continue the ignition sequence. A silicone tube connects the blower vacuum switch with the blower as shown in Figure 1.

To remove the blower vacuum switch:

1. Turn pump, gas supply, and heater power "OFF".
2. Remove the front access panel.
3. Remove the wires from the vacuum switch.
4. Pull the tubing from the hose barb on the switch.
5. Remove the (2) screws that secure the pressure switch to the control panel.
6. Replace the pressure switch and reverse the above procedure to reassemble unit.

HIGH LIMIT SWITCHES: The heater is equipped with two automatic high limits, located on the water header. These high limits are automatically resetting safety devices wired in series with the thermostat and gas valve. See Figure 23. If the water temperature exceeds the limit setpoint, the gas valve will be closed, shutting off gas supply to the burners. Erratic high limit operation is an indication of water flow issues. Reduced flow may be caused by a clogged filter or strainer, excessive flow through the external bypass (if one is used), or lime scale accumulation in the heat exchanger.

To replace a high limit switch:

1. Turn pump, gas supply, and heater power "OFF".
2. Drain the heat exchanger of all water.
3. Unplug the high limit wires from the wiring harness.
4. Unscrew the high limit switch from the header.
5. Replace the high limit switch. Use new sealant on the high limit switch threads before reinstalling.
6. Reverse the above procedure to reassemble unit.

VENT PRESSURE SWITCH: The vent pressure switch is a safety device that disables the unit when the flue opening is blocked, which prevents sufficient combustion gas flow through the unit. When the flue is blocked, pressure is created and opens the contacts on the vent pressure switch, directing the ignition control board to deactivate the unit. A silicone tube connects the vent pressure switch to the blower as shown in Figure 1.

To remove the vent pressure switch:

1. Turn pump, gas supply, and heater power "OFF".
2. Remove the front access panel.
3. Remove the wires from the pressure switch.
4. Pull the tubing from the hose barb on the switch.
5. Remove the (2) screws that secure the pressure switch to the heater.
6. Replace the pressure switch and reverse the above procedure to reassemble unit.

EXHAUST GAS TEMPERATURE LIMIT: The exhaust gas temperature limit monitors the flue gas temperature above the heat exchanger and opens when the temperature rises high enough to indicate that the heat exchanger is no longer transferring heat to the pool water effectively. If the temperature limit opens, effort must be made to assess and rectify the condition that activated the temperature limit and potentially damaged the heat exchanger. The condition is generally low water flow and/or scaling of the heat exchanger cupronickel tubes from poor water chemistry. Replace the limit as well as the heat exchanger, if needed, before operating the unit again.

To replace the exhaust gas temperature limit:

1. Turn pump, gas supply, and heater power "OFF".
2. Remove the upper end cap on the header side of the unit (see Page 6).



3. Unplug the two wires from the exhaust gas temperature limit located in the flue collector panel above the middle of the header.
4. Unscrew the (2) screws securing the limit to the panel and remove the limit and gasket.
5. Place the new limit and gasket in place and reverse the above procedure to reassemble unit.

THERMISTOR: The thermistor monitors the return water temperature to thermostatically control pool and spa water to the selected temperature and to shut the heater off as the return water reaches 104 F. See Figure 23.

To replace the thermistor:

1. Turn pump, gas supply, and heater power "OFF".
2. Drain the heat exchanger of all water.
3. Remove the front access panel.
4. Unplug the thermistor connector from the ignition control board.
5. From outside the heater, pull the thermistor leads out of the control box and through the hole in the heater chassis.
6. Unscrew the thermistor from the inlet side of the header.
7. Replace the thermistor. Use new sealant on the thermistor threads before re-installing.
8. Reverse procedure above to reassemble unit.

WATER PRESSURE SWITCH: The water pressure switch (See Figure 23) is preset at the factory for most typical, deck level installations. When the heater is located above or below the level of the pool or spa, the pressure switch may require adjustment to compensate for the change in static head pressure. If adjustment is needed, the procedure is detailed in **WATER PRESSURE SWITCH TEST / ADJUSTMENT PROCEDURE**.

▲ NOTICE – Do not operate the pool heater without the function of a properly adjusted pressure switch or flow switch.

To replace the pressure switch:

1. Turn pump, gas supply, and heater power "OFF".
2. Remove the (4) screws securing the upper end panel and remove the panel.
3. Remove the (2) screws securing metal trim panel to the upper trim panel.
4. Remove the wires from the pressure switch.
5. Unscrew switch from header.
6. Replace the pressure switch. Use new sealant on the pressure switch threads before re-installing.
7. Reverse procedure above to reassemble unit.

TRANSFORMER: The transformer converts the field supply voltage (either 240 VAC or 120 VAC) to a 120 VAC output for blower and igniter power, and a 24 VAC output for powering the ignition control board, control circuits, and gas valve.

To replace the transformer:

1. Turn pump, gas supply, and heater power "OFF".
2. Remove the front access panel.
3. Unplug transformer from the fuse board
4. Remove the (2) screws that secure the transformer to the control box.
5. Replace the transformer.
6. Reverse procedure above to reassemble unit.

BYPASS SERVICE CARTRIDGE: The following procedure details how to remove and replace the internal pressure bypass valve in the header. This procedure applies only to plastic (non-ASME) headers. On bronze (ASME) headers, the bypass service cartridge is not field-replaceable. Please contact technical support for more information.

1. Turn pump, main gas valve, and heater power off.
2. Drain heat exchanger according to instructions in this manual.
3. Remove 6 screws and remove the upper plastic heater side panel, to allow access to the header.
4. Remove the cartridge retaining nut from end of header (see Figure 23).
5. Slide out the bypass cartridge from the end of the header (see Figure 23).
6. Check the function of the bypass valve to ensure the valve flaps rotate smoothly on the shaft, and the spring fully closes the valve.
7. Apply silicone O-Ring grease (Jack's 327 Multilube p/n SP032712, or equivalent) on O-Ring seals on the bypass cartridge before inserting into the header.
8. Insert bypass cartridge into header with the arrow on the end of the cartridge pointing up.
9. Re-install cartridge retaining nut. Nut should be tightened hand-tight only. DO NOT OVER-TIGHTEN.
10. Re-install the upper plastic heater side panel.
11. Reverse procedure above to reassemble unit.

COMBUSTION BLOWER: The blower provides the air that mixes with the gas in the burners for the combustion process. The blower operates during the pre-purge time (approximately 30 seconds) at the beginning of each ignition cycle, during the entire time the gas valve is open and the burners are firing, and for 30 seconds after the gas valve closes. See Figure 1 and Figure 25. To replace the blower:

1. Turn pump, gas supply, and heater power "OFF".
2. Remove the front access panel.
3. Disconnect the blower wire harness from the ignition control board.
4. Disconnect the tubing from the hose barb on the blower housing.
5. Remove the blower from the air box cover (4 screws).
6. Remove the blower air inlet plate from the blower (4 screws).
7. Be sure the blower outlet gasket is in place before proceeding. Reverse the above procedure to reassemble the blower.

Figure 25: Combustion Blower

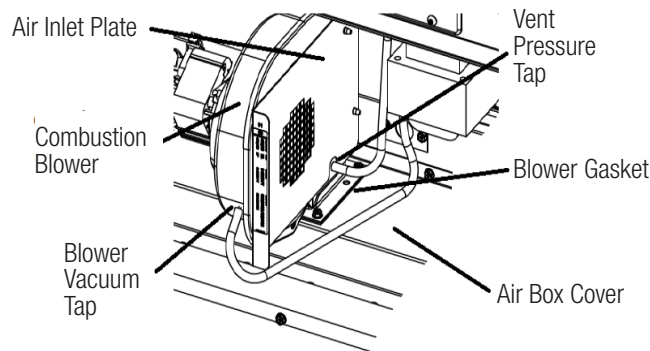



Troubleshooting

Error and Display Codes: See Table 17: Display Code Index.

Troubleshooting the Unit: See Table 18: Troubleshooting Lookup Chart.

AUTOMATIC RESET TIME: The heater will automatically reset when an error condition is corrected and resume operation. The heater can be manually reset using the keypad by cycling the MODE button through "STANDBY" and back to the original operating mode ("POOL" or "SPA").

⚠ WARNING – These instructions are intended for the use of qualified personnel trained and experienced in the installation and servicing of this type of heating equipment and its related system components. Some states may require installation and service personnel to be licensed. Persons not qualified should not attempt to repair this equipment according to these instructions. These instructions and procedures are not for the use of "do-it-yourself" consumers.

⚠ WARNING – Burn Hazard. The operation of the heater with the pump shut off could cause heater overheating and fire. Never operate heater with the pump shut off.

⚠ NOTICE – As a preliminary check, make sure that all wire connections are clean and tight and that all wiring conforms to the wiring diagram.

FAILURE TO LIGHT – RETRY: If the first ignition attempt fails during a normal heating cycle the control will make two (2) additional ignition attempts:

1. The control de-energizes the gas valve after the 4-second ignition trial ends.
2. The control operates the blower during a 30-second post-purge period.
3. The control monitors for open contacts at the blower vacuum switch.
4. The control performs a gas valve relay check.
5. A normal ignition sequence resumes with Item #2 in NORMAL OPERATION FOR POOL & SPA MODES (see above). If the third ignition trial fails the control enters a safety lockout (or "hard" lockout) after the post purge period of the third failed trial.
6. The error code "IF" is displayed and the "SERVICE" indicator is illuminated.
 - a. The control automatically resets and clears the "IF" error code without any user intervention after 60 minutes. If there is a call for heat after reset, the control will make three (3) trials for ignition. If ignition is not established the control will again enter safety lockout for 60 minutes. This cycle will continue until ignition is established or the call for heat is removed.
 - b. The user can reset the control and clear the "IF" error code by pressing the "MODE" button to move through "STANDBY" and return to the previous mode ("POOL" or "SPA").

LOSS OF FLAME – RECYCLE: If flame is established and then lost, the control will make ten (10) attempts at ignition. If flame is lost within ten (10) seconds of ignition, the control will respond within 2 seconds. If flame is lost more than ten (10) seconds after ignition the control will respond within 0.8 seconds.

1. The control de-energizes the gas valve and the blower.
2. The control monitors for open contacts at the blower vacuum switch.
3. The control performs a gas valve relay check.
4. A normal ignition sequence resumes with Item #2 in NORMAL OPERATION FOR POOL & SPA MODES (see above).
5. If the tenth ignition trial fails the control enters a safety lockout (or "hard" lockout) after the post-purge period of the tenth failed trial.
6. The error code "IF" is displayed and the "SERVICE" indicator is illuminated.
 - a. The control automatically resets after 60 minutes. If there is a call for heat after reset the control will make three (3) trials for ignition. If ignition is not established the control will again enter safety lockout for 60 minutes. If flame is established but is lost the control will make ten (10) attempts at ignition. This cycle will continue until ignition is established or the call for heat is removed.
 - b. The user can reset the control and clear the "IF" error code by pressing the "MODE" button to move through "STANDBY" and return to the previous mode ("POOL" or "SPA").

FUSE SPECIFICATIONS: The fuse designations are printed on the power board and the ignition control board. Fuses are available as common hardware items or may be purchased from manufacturer in a service parts kit. The fuse specifications are:

- F1 fuse (low voltage): 3A blade style fast-acting automotive fuse, type 257
- FC1 & FC2 (transformer primary) and FC4 (transformer secondary): 3A slo-blo fuse, 5 x 20 mm

INTERNAL WIRING: If the heater display is blank after the electrical has been installed, refer to Troubleshooting Lookup Chart to determine the cause. Note, the ribbon cable between the display board and the ignition control board is keyed to ensure correct connection.

SUPPLY WIRING: If the heater is connected to the line side of the circuit it will be powered at all times. In this situation, when the pump shuts down the heater will display a fault code of "LO". If there is a call for heat and the pump then restarts there will be a 2-minute delay for the heater to fire. After the pump has been running for at least 2 minutes there is no delay for heater operation. Wiring the heater to the load side of the timer or controller will not result in a 2-minute delay if the pump primes quickly enough to activate the heater's water pressure switch. If the pump is slow to prime the heater may display an "LO" fault code and will take 2 minutes to automatically restart. If the pump has primed, this wait can be avoided by manually clearing the error code via the keypad by changing the mode through the "STANDBY" setting and returning to the initial setting ("SPA" or "POOL"). When a heater is wired to the line side of the power circuit (continuous power) the blower will not operate when the pump is cycled via a time clock or other switch method.



Table 17: Display Code Index

Code	Error	Description
AC	Air Pressure Switch Stuck Closed	If the control senses that the air pressure switch is closed for greater than 60 seconds when it should be open during a call for heat, the control will display the error code "AC" and leave the inducer de-energized. Once the air pressure switch is opened, the control will proceed with the ignition sequence.
AO	Air pressure Switch Stuck Open Prior To Warm-Up	Prior to warm-up, if the inducer is energized and the control senses that the air pressure switch is open for greater than 60 seconds, the control will display the error code "AO", and leave the inducer energized. Once the air pressure switch is closed, the control will proceed with the ignition sequence.
AO	Air pressure Switch Open During /After Igniter Warm-Up (except during post-purge)	If the control senses that the air pressure switch is opened for greater than 1 second any time during or after the igniter warm-up period, but not during post-purge, the control will de-energize the inducer and the gas valve and start the ignition sequence from the beginning except without performing a pre-purge period. When the new ignition sequence is started, if the air pressure switch is still detected open 60 seconds after the inducer is energized, the control will display the error code "AO", and leave the inducer energized. Once the air pressure switch is closed, the control will proceed with the ignition sequence.
AO	Air pressure Switch Opens During the Post-purge Period	If the control senses that the air pressure switch is open for greater than 1 second any time during the post-purge period, the control will stay within the post-purge routine until the air pressure switch closes, after 60 seconds will display the error code "AO". After the air pressure switch is closed, the control will then clear the display, restart the post-purge routine and continue normal operation.
bd	Internal Fault/Power Up Error	If the power-up gas valve relay check fails, the control will not attempt to operate and will leave all outputs off and display the error code "bd". The control will remain in this state until the gas valve relay check results are acceptable, and will then resume normal operation.
bd	Gas Valve Sensed Energized When It Should Be Off	If the control senses the gas valve is energized for greater than 4.25 seconds when it should be off, the control will immediately go to lockout, energize the inducer for a 30 second purge time, and display the error code "bd". After the 30 second purge time, the control will turn off the inducer and monitor if the error condition is still present. If the error condition is still present, the inducer will be energized and remain on as long as the error condition is sensed. Once the control senses the gas valve status is not in error, the inducer will remain energized for a 30 second purge. The control will also set the automatic restart time equal to 120 seconds. The control will automatically restart after the automatic restart time has expired.
bd	Gas Valve Sensed As Not Energized After Successful Trial For Ignition	If the control senses the gas valve has not energized for greater than 4.25 seconds after flame has been detected, the control will continue to run the inducer for 5 seconds, then start a new ignition sequence. If this fault happens 10 times during the same call for heat, the control will finish the 5 second purge period, display the error code "bd", and go into lockout. The control will automatically reset after the 60-minute automatic reset timer has expired.
bd	Data Retrieval Error	If data is found to be corrupt (i.e. bad checksum), the control will enter a hard lockout with all outputs off and display the error code "bd". If either the set point or offset data is invalid, the control will default to the factory setting.
CE	Communication Error	A communication error will be displayed if communication is not established within 3 seconds after the display module is first powered. Once communication has been established, the delay to reporting an error is 30 seconds. One valid message exchange between the Ignition module and display module will clear the communication error.
HF	Flame Present With The Gas Valve Not Energized	If the control senses flame is present for greater than 4.25 seconds with the gas valve not energized, the control will enter lockout, display the error code "HF", and energize the inducer. When the flame fault is no longer present, the control will start a 5 second purge period then reset after the 120-second automatic restart timer has expired.
HS	Excessive Water Temperature	If the control determines during a 30 second debounce period that the average temperature readings of the two thermistors is in excess of 105°F, the control will act to terminate the call for heat. The inducer will be shut off after the post-purge period and the error code "HS" displayed. If the control is in standby, the error condition will be masked, but the control will still be in safety lockout. Normal operation will resume when the water temperature drops below 105°F and the 120-second automatic restart timer has expired or any key is pressed and the 7-second restart timer has expired.
IF	Retry / Recycle Count Limit	If the control exceeds the maximum number of retries or recycles it will go into a timed lockout with all outputs off, except for the inducer, which will shut off after the post-purge period. The display will show the error code "IF". After the 60 minute Automatic Reset Time has expired the control will clear the counters, clear the display, and return to normal operation.
IO	Open Igniter or Triac Fault	When the inducer is energized outside of a lockout condition and the control senses that the igniter is open or the triac is not operating correctly, it will go to lockout, turn off the inducer and display the error code "IO". The control will automatically restart after the 120-second automatic restart timer has expired.

Code	Error	Description
LO	Limit String Open	<p>If there is a call for heat and the control detects that the limit string is open, the call for heat is terminated, and the inducer is shut off after the post-purge period. The error code "LO" will be displayed. The control will resume normal operation after the limit string is detected closed and the 120-second automatic restart timer has expired or any key is pressed and the 7-second restart timer has expired.</p> <p>The control determines that the "LO" error code is the result of the water pressure switch opening in the limit string if the following conditions are present: no call for heat; confirmed no 24VAC at the gas valve; no flame present; and the inducer is off. The control will enter into an "idle" or "wait" state and will display an "LO" error code but will not enter safety lockout. If the limit string closes the control will resume normal operation.</p> <p>If the "LO" error code is generated during a call for heat or when the inducer is energized the control will assume that one or more of the thermal limit switches are open, or the vent pressure switch, and enter a safety lockout.</p>
PF	120VAC Line Miswiring	<p>The control requires correct polarity of the 120 VAC wiring and a ground wire connection for proper operation. If the polarity is reversed, low voltage is detected, or the ground is not properly connected, the control will display the error code "PF". The control will restart as soon as the error condition is corrected.</p>
Sb	Temperature Adjust Button Stuck Closed	<p>If the control determines one of the keypad buttons is stuck closed for longer than 30 seconds, the display will show the error code for "Sb" and will continue to function in an otherwise normal manner using set point and mode data existing immediately before the button was detected closed. The error code will be immediately cleared when the condition is corrected.</p>
SF	Thermistors Open, Shorted or Mismatched	<p>Thermistor errors can be generated by either an excessive difference in the readings between the thermistors ($\Delta \geq 5^{\circ}\text{F}$) or as a result of an "out of bounds" condition on both thermistors (measured temperature is $\leq 10^{\circ}\text{F}$ or $\geq 180^{\circ}\text{F}$). If the control determines during a 30 second debounce period that either of these conditions exist, it will act to terminate the call for heat (if applicable) after the post-purge period and display the error code "SF". The minimum lockout time in this mode is 120 seconds. After the 120 second period, the software will auto-start 3 seconds after the error is corrected. If the error is corrected prior to the expiration of the 120-second timer, the software will auto-restart right at the 120-second mark.</p>

- ⚠ WARNING** – Pool heaters are heat producing appliances. To avoid possible over heating of the outer jacket and damage or injury with such an event: (1) no materials should be stored against the jacket and (2) care should be taken to avoid unnecessary contact (especially by children) with the jacket.
- ⚠ WARNING** – When lighting a gas heater, the lighting instructions must be followed exactly to prevent "flashback" of excess gas in the heater. Electronic ignition heaters and electric heaters must have the power shut off when making adjustments for servicing, or coming into contact with the heater.
- ⚠ WARNING** – UNDER NO CIRCUMSTANCES SHOULD FLAMMABLE MATERIALS, SUCH AS GASOLINE OR PAINT THINNERS, BE USED OR STORED IN THE VICINITY OF THE HEATER OR IN ANY LOCATION FROM WHICH FUMES COULD REACH THE HEATER.



Service Parts

The following service parts and kits are available from Hayward and through your local distributor. When ordering parts, include the complete heater model number listed on the unit's rating plate. (Example: H400FDN) All service must be performed by a qualified technician.

Cabinet Parts

- Control Access Panel
- Cabinet Top
- Header Controls Cover
- Water Side Trim Panels
- Cabinet Base

Electronic Controls

- Ignition Control Board
- Field Wiring Panel (Fuse Board)
- Universal Display
- Inlet Water Thermistor
- Water Pressure Switch
- High Temperature Limits
- Exhaust Temperature Limit
- Blower Pressure Switch
- Vent Pressure Switch
- Transformer
- Ignitor
- Flame Sensor
- Voltage Selector Jumper
- Fuses
- Wiring Harnesses
- Electric Accessory Kit

Heating Components

- Combustion Blower
- Burner
- Combustion Chamber
- Heat Exchanger Assy

Water Manifold Components

- Header Assembly
- Union Flange
- Pressure Relief Port Plug
- Drain Plug

Miscellaneous Kits

- Gasket Kit
- Header O-Ring Kit
- Gas Conversion Kits (Natural or LP)
- Electrical Accessory Kit
- Pressure Switch Hose

Accessory Kits

- High Altitude Conversion Kit
- Indoor Vent Adapters
- Consumer Kit



THIS PAGE IS INTENTIONALLY LEFT BLANK



THIS PAGE IS INTENTIONALLY LEFT BLANK



HAYWARD® Pool Products Limited Warranty

Hayward Pool Products, Inc., warrants the components of this product to be free from defects in materials and workmanship during the warranty period. Please visit <https://hayward.com/support/resources/warranty> for product warranty details.

The limited warranty excludes damage from freezing, negligence, improper installation, improper use or care, Acts of God or as specified in installation and operations manual. Parts that fail or become defective during the warranty period shall be repaired or replaced, at our option.

Proof of purchase is required for warranty service. In the event proof of purchase is not available, the manufacturing date of the product will be the sole determination of the purchase date.

To obtain warranty service, please contact the place of purchase or the nearest Hayward Authorized Service Center. For assistance on your nearest Hayward Authorized Service Center, please visit us at <https://hayward.com/dealerlocator>.

Hayward shall not be responsible for cartage, removal, repair or installation labor or any other such costs incurred in obtaining warranty replacements or repair.

The Hayward Pool products warranty does not apply to components manufactured by others. For such products, the warranty established by the respective manufacturer will apply.

The express limited warranty above constitutes the entire warranty of Hayward Pool Products with respect to its pool products and is in lieu of all other warranties expressed or implied, including warranties of merchantability or fitness for a particular purpose. In no event shall Hayward Pool products be responsible for any consequential, special or incidental damages of any nature.

Some states do not allow a limitation on how long an implied warranty lasts, or the exclusion of incidental or consequential damages, so the above limitation may not apply to you. This warranty gives you specific legal rights, and you may also have other rights, which vary from state to state.

Hayward Industries, 1415 Vantage Park Dr., Suite 400, Charlotte, NC 28203

***Supersedes all previous publications**

Register your product at <https://hayward.com/support/resources/warranty/product-registration>