



USER GUIDE

| | |
|-------------------------------------|----|
| FREQUENTLY ASKED QUESTIONS | 2 |
| BATTERY INSTALLATION AND USE | 4 |
| CORD CARE, MOTOR SAFETY, ANTI-THEFT | 5 |
| PROP AND MOTOR/CORD REMOVAL | 6 |
| SETTING UP THE MOUNT ASSEMBLY | 7 |
| ALL ABOUT DEBRIS BAGS | 8 |
| GENERAL OPERATING PROCEDURE | 9 |
| USING THE HH1062 SMART SWITCH | 10 |
| TROUBLESHOOTING GUIDE | 11 |
| WIRING DIAGRAMS | 12 |
| WARRANTY STATEMENT | 14 |

hammerheadvac.com/learn

info@hammerheadvac.com

561-278-8992

FREQUENTLY ASKED QUESTIONS

The HAMMER-HEAD gives you maximum vacuuming power in a small, lightweight, portable package. That is what sets our cleaner apart from conventional vacuum systems. Our 12-volt rechargeable unit has you cleaning immediately without the usual set-up and run-around.

WHAT WILL IT DO?

Just lower it into the water and turn it on. The patented pressurized motor can entirely recirculate the average pool in under an hour, and vacuum it clean in under ten minutes. Sand, sticks, leaves, and even coins are pulled into the high capacity debris bag, reducing the number of filter cleanings. You'll use less effort, too.

WHAT WON'T IT DO?

Hammer-Head units equipped with a standard debris bag can vacuum up large leaves, coarse sand, sticks, mulch, small gravel and even some coins. With a superfine debris bag (HH1508) or ultra-fine volcano bag (HH1510), you'll be able to pick up almost all finer silt and dust. It will not filter algae out of the water, and it is not a complete substitute for the pool's filtration system or filtration vacuuming. There will be cases where the filtration system is the best way to clean the pool. For all other cases, however, the advantage to using the Hammer-Head is that the debris goes into the bag, it stays out of the filter system. This means fewer filter cleanings, and less strain on the pool equipment.

WHY WOULD I WANT TO USE ONE?

Hammer-Head can help you increase your profitability. In the pool business, time is definitely money, and the rapid setup and working speed of the Hammer-Head unit will cut your pool vacuuming time by as much as 50%. If your goal is to shorten your workday, or if you want to take on more work, you will save time with a Hammer-Head.

What is your time worth to you? In the maintenance business, time really is money, and any tool that saves you time is an investment in your own profitability. Faster cleaning times means more pools can be serviced in a day, leaving time for repair work or opening new accounts. Your Hammer-Head will pay for itself in time savings alone and will leave you wondering how you ever got by without one.

DO I HAVE TO BE TRAINED TO OPERATE IT?

A Hammer-Head isn't that much different than your household vacuum cleaner. The cart is balanced, rolls easily over most terrain, and carries most of what you need in one trip. You'll expend less energy on the job. Just attach a standard pool pole, lower it into the water, and turn it on. It's that easy.

IS IT SAFE FOR VINYL LINER POOLS?

Yes. The Hammer-Head vacuum head has over 1" of clearance from the pool bottom, so scuffing or tearing a liner is not an easy thing to do. And because the Hammer-Head vacuum head design has wheels on the outside of the head, they protect it from making contact with the liner. The Hammer-Head suction is very powerful, but it can't lift the liner off the bottom because it's not close enough to it. We also make a brush attachment for the 21" head that lifts the vacuum off the bottom on firm brush bristles. It will change the steering, but raise the clearance even more.

WHAT IS THE MINIMUM WATER DEPTH?

Hammer-Head cleaners operate in any water depth greater than 12 inches. The debris bag does not have to be fully submerged for the vacuum to work, but the propeller on the motor must be underwater. Hammer-Head vacuums do not vacuum on dry land.

IS IT SAFE TO VACUUM WHILE SWIMMERS ARE IN THE WATER?

The Hammer-Head uses safe 12 volt DC power to operate. Although it is easier to vacuum a pool when there are no swimmers present, there is no electrocution danger to swimmers when the Hammer-Head is battery powered and in use.

HOW DOES IT MOUNT TO MY TRUCK OR TRAILER?

The SERVICE-21 mounts to any truck equipped with a 2" REESE type hitch receiver. It mounts to any trailer with a set of U-bolts (included). The cart is secured to the mount with a toggle clamp latch and a safety pin. The Resort-30 and Resort-21 units use different carts and do not mount.

CAN I GET A RESORT-30 UNIT THAT CAN MOUNT?

No, but... Some prefer the larger head and longer cord on the RESORT-30, but need a portable unit for their daily pool route, so we offer the SERVICE-30 as an alternative. It has the longer cord (60') and larger head (30") and also includes the mount system.

WHAT IS THE DIFFERENCE BETWEEN THE RESORT UNIT AND THE SERVICE UNIT?

The Resort units and Service units both use the same motors and the same interchangeable parts. The main difference between the two is in the cart design. Our service units are designed for pool to pool service route work and are ready to mount on your truck or trailer. Resort units are designed for maintenance work where the unit will be left on site, and are not compatible with the vehicle mount assembly. Resort-30 units have been used by aquatic facility managers around the US and abroad. Disney Resorts, Sea World, the US ARMY, the YMCA, cruise lines, countless country clubs, condominium associations, and municipalities have relied on the portability and ease of use that make the Resort-30 and Resort-21 the only economical equipment choice.

IS THERE A WARRANTY? CAN I GET PARTS?

Hammer-Head units are backed by a limited one year warranty, and we offer a full compliment of readily available parts through your dealer/distributor, and service through Hammer-Head to keep your cleaner's motor working smoothly year after year.

CAN I JUST PLUG IT INTO A WALL SOCKET?

NO. The HAMMER-HEAD is designed to accept a 12 volt deep cycle marine battery as a power source (not included), and the use of any other power source is not advised. Attempting to use any other power source can damage the unit and/or put you at risk of electric shock. You can use any 12 volt battery of any size, but typically, the bigger the battery, the longer the run time. Deep-cycle batteries are the only batteries that will last. It is possible to run the Hammer-Head using a 110 volt AC to 12 volt DC converter, we do not recommend operating the unit in this way due to the higher risk of electrocution. Please call to discuss the necessary specifications using a converter.

WHAT KIND OF BATTERY AND CHARGER WILL I NEED?

We suggest the use of a 12 volt deep-cycle marine battery and an automatic charger that can charge at a minimum of 6 amps and no more than 10-12 amps. Automatic chargers will charge the battery to full capacity and then adjust automatically to a lower charging rate to maintain the charge. Charge your battery every day and leave it connected to the automatic charger when not in use. This will lengthen the battery life. *DO NOT TRICKLE CHARGE. DO NOT USE A CAR BATTERY.*

Marine batteries typically come in series sizes 24, 27, and 30. We suggest a series 27 size battery. The bigger the battery, the longer the run-time. Avoid marine starting batteries. A general purpose trolling motor battery will work fine. We do not recommend using marine starting or cranking batteries due to their shorter life span. Sealed, or maintenance-free batteries are a good idea so you don't have to check liquid levels. These items are available at super stores, marine supply stores, auto supply stores, and some buyer's clubs. Make sure you charge your new battery before using it for the first time. Hammer-Head strongly suggests that you use a deep-cycle marine gel battery for the best performance and longest life.

For more information about gel batteries and chargers, visit www.poolandmarine.com

BATTERY USE AND LIABILITY

Thousands of Hammer-Head pool cleaning units are currently in use across the United States and in other parts of the world. With proper care they will provide years of dependable service. Please review the following safety information.

WARNING: IMPROPER BATTERY USE OR FAILURE TO INSPECT AND MAINTAIN YOUR 12 VOLT BATTERY CAN RESULT IN SHORT CIRCUITS, DAMAGE DUE TO OVERHEATING, BATTERY FAILURE, AND POSSIBLE FIRE OR PERSONAL INJURY.

THE OPERATOR ASSUMES ALL RESPONSIBILITY AND/OR RISK ASSOCIATED WITH THE USE OF ANY HAMMER-HEAD PRODUCT, INCLUDING BATTERY SELECTION, INSTALLATION, USE, AND MAINTENANCE. USE OF ANY POWER SOURCE OTHER THAN A 12 VOLT DEEP CYCLE MARINE BATTERY IS NOT RECOMMENDED AND CAN VOID ALL WARRANTY OR LIABILITY CLAIMS.

- Wiring connections must be inspected daily. Wires that are hot to the touch indicate a connection problem and should be repaired. Hammer-Head units that are not working properly should be either repaired immediately or disconnected from all power sources and removed from service.
- Do not place anything in the battery box that can bridge the terminals on the battery - this can cause direct short circuits and possible fire or even battery explosion.
- If you reverse the positive and negative wire connections on your battery, the motor will run in reverse and the vacuum will suck the bag into the propeller. (If you have the HH1062 Smart Switch, the switch will not allow the unit to run if the wires are reversed).

INSTALLING YOUR BATTERY



1. Remove the accessory tray from the cart. Lift the battery box lid up and push it through to the back of the unit, under the V-Tray panel.



2. Tilt the battery box forward and pull the wires out to the side. (Additional parts may be stored inside the battery box for shipping).



3. Slide the battery into the box with the terminal posts facing toward you.

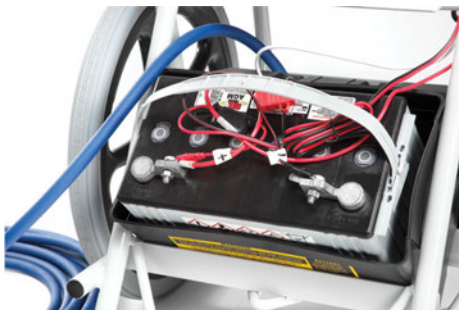

4. Connect the red wires to the positive (+) terminals and the black wires to the negative (-) terminals. Tighten securely.



5. Tilt the battery box back into place using the handle on the battery. Pull the battery box lid back through the cart to the front and replace the cover.



6. Secure the lid with the bungee cord. To charge the battery with a traditional battery charger, simply lift the lid and connect the charging clips to the battery terminals.

CORD CARE

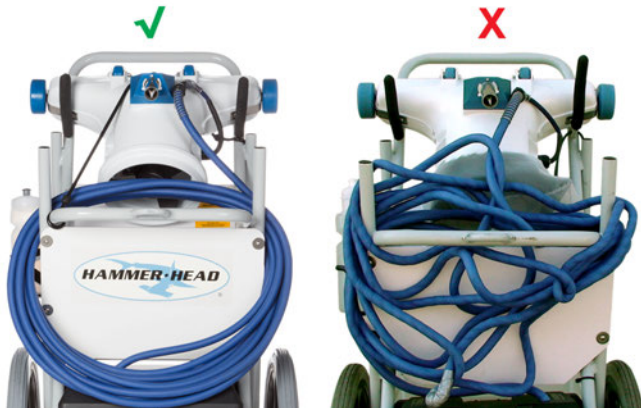

- Poor power cord maintenance drastically shortens the life of the motor assembly. Store the cord in large loops as shown - Do not wind the cord up tightly.
- Avoid kinking the power cord or sucking it up into the vacuum head.
- Avoid pinching the power cord in the mount assembly when mounting the unit on to your vehicle.
- After vacuuming, remove any twists in the cord by coiling the cord starting from the cart and ending at the vacuum head. The head can roll across the deck on its wheels, allowing you to take the twists out by spinning the vacuum head before you put it on to the cart rest.

HOW CAN I KEEP MY SERVICE UNIT FROM BEING STOLEN?

Unfortunately, theft of Hammer-Head units is on the rise. The easiest way to secure your cleaning unit is to put a padlock through the mount ring on the cart frame (as shown here). If the lock is in place, the cart can't easily be removed from the mount assembly.

We also suggest using a locking hitch pin. (Hitch pins are not included with the HH1300 mount assembly or with complete Service-type cleaning units and cart assemblies.

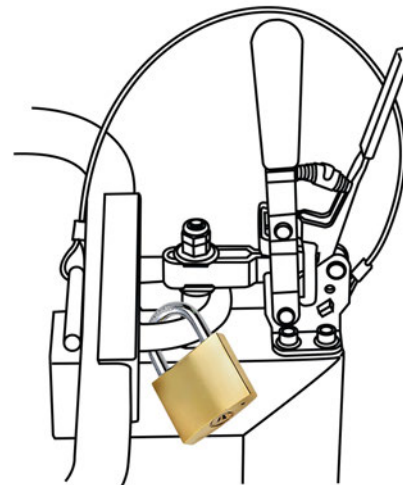

MOTOR SAFETY & CARE

- Do not run the motor out of the water longer than three minutes.
- Do not attempt to remove or replace the bag or reach into the vacuum head while the motor is running.
- Hammer-Head units are very durable, but it is often better to scoop toys, rocks, sticks, or tree seeds out of the pool before vacuuming to avoid jamming or breaking the propeller.
- Heavy piles of leaves can sometimes clog the vacuum. One way to clear clogs without stopping is to turn the unit off and on a few times. (If you have the HH1062 Smart Switch, the motor will do this automatically three times to clear the obstruction). You can also try raising the vacuum up to the surface and slightly out of the water. When the vacuum sucks in a little air, it can loosen clogged debris so that it will pass into the bag.
- If the motor stops abruptly while cleaning, turn the unit off as quickly as you can to avoid damaging the unit. (The HH1062 Smart Switch will prevent the motor from overheating in the event of a propeller jam). Some units may also be equipped with a 30amp blade-type automotive fuse to prevent a motor overheat. If a motor jam occurs on a unit equipped with a fuse, the fuse must be replaced before the unit will turn on again. (Spare fuses can be purchased from any automotive parts supply store.
- Do not open the motor or disconnect the blue power cord from the motor assembly. Doing so voids the warranty and exposes the motor to water damage.
- Motor/cord assemblies are sold through you dealer as a sealed unit. Damaged motors can also can be rebuilt. For more information on motor repairs, please download a repair form here: <https://www.hammerheadvac.com/downloads/>
- Need help? Please refer to our troubleshooting guide before you call. (The troubleshooting chart is included in this user guide or you can find one here: <https://www.hammerheadvac.com/downloads/>

REMOVING AND REINSTALLING THE PROPELLER



1. Locate the prop nut in the center of the propeller. It looks like this:



2. To remove the prop nut: Hold the propeller with one hand and turn the prop nut counter-clockwise with the other hand.



3. Once the prop nut is off, you will be able to remove the propeller from the motor shaft by lifting it up.



4. Locate the groove on the bottom of the propeller and the prop pin that goes through the shaft. (When re-installing the propeller, the prop groove must be seated on the pin). Remove the pin from the shaft. **DO NOT LOSE THE PIN!**



5. With the pin out, clean any debris that may be wrapped around the motor shaft.

To re-install the propeller, just reverse this sequence. Do not use tools to tighten the prop nut. Hand-tighten only.

Weekly prop debris removal is an important part of routine cleaner maintenance. Excess debris can build up around the prop shaft and compromise the watertight seal.

Propellers are durable but over time the leading edge can become rough. Props can be sharpened with a file to remove burrs and nicks. This makes the prop run more smoothly and keeps debris from snagging on it while you vacuum. Remove the propeller before attempting to sharpen it.

REMOVING AND REINSTALLING THE MOTOR/CORD ASSEMBLY



1. Remove the screws located on either side of the vacuum head (4), and 1 screw holding the cord clamp to the pole yoke block. Leave the wheels in place.



2. Remove the propeller nut, propeller, and propeller pin. (Refer to REMOVING THE PROP guide for instructions).



3. Working from the top, gently pry the head halves apart and lift the motor assembly up and out of the vacuum head. (Reverse this procedure to install the motor/cord assembly).

IMPORTANT: DO NOT attempt to remove the cord from the motor, open the black cord nut, or open the motor in any way. Doing so can void the warranty and compromise the watertight seal.

Setting up the Hammer-Head HH1300 MOUNT ASSEMBLY

NOTE: Your vehicle (or trailer) must have a 2" hitch to use the mount assembly.

If you are not using the hitch adapter for trailer mounting, then U-bolt the Hammer-Head mount directly to the trailer wall in an area that can support the total weight sufficiently (approximately 130-140 lbs). The use of straps or braces from the vehicle to the top of the mount upright can provide additional support.

INSTRUCTIONS:

Bolt the hitch adapter to the mount upright using the included u-bolts so that the bottom of the mount upright will be at least 12-16 inches from the road surface. The cart wheels should be high enough so that they do not make contact with steep driveways or speed bumps. Do not set up with the cart tires rolling on the road.

The lower u-bolt can be placed under the lower u-channel if more height is needed or above it if less height is needed.

WARNING! WARNING! WARNING!

Make sure to tighten the hardware sufficiently to avoid slippage.

Check all hardware and mount components regularly for tightness, corrosion, and wear.

Do not transport your Hammer-Head unit with chemicals in the accessory tray.

Secure all loose items on your Hammer-Head unit before driving.

Refer to the clamp latch adjustment detail (at right) to properly adjust the clamp latch. Do not use the clamp latch without first adjusting the fit and checking all four safety points.

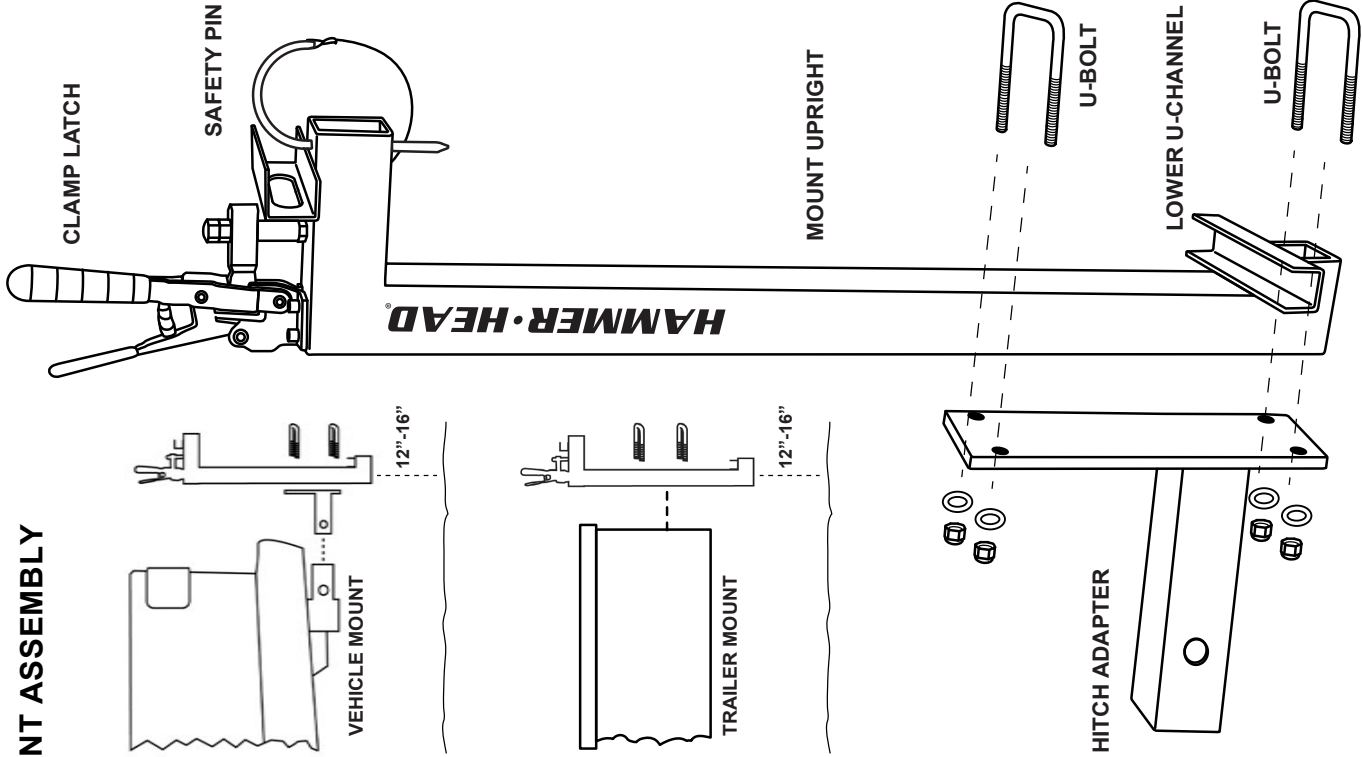

CLAMP LATCH ADJUSTMENT DETAIL

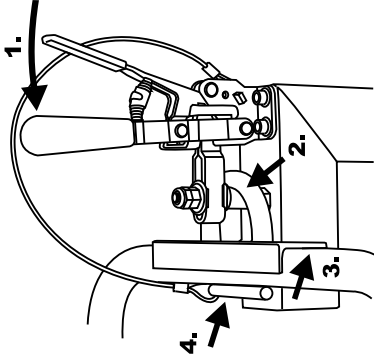

WARNING!

CHECK THESE FOUR SAFETY POINTS BEFORE USING THIS MOUNTING DEVICE:

- 1.** CLAMP LATCH MUST BE PUSHED COMPLETELY FORWARD UNTIL IT LOCKS INTO PLACE AND SPRING POPS OPEN
 - 2.** BOTH NUTS ON THE LATCH BOLT MUST BE TIGHTENED DOWN AND THE BOLT PIN SHOULD MAKE CONTACT WITH CART MOUNT LOOP WHEN LATCHING
 - 3.** CART FRAME MUST MAKE CONTACT WITH MOUNT CHANNEL WHEN CLAMP IS LOCKED DOWN
 - 4.** ALWAYS USE THE SAFETY PIN
- FAILURE TO MAINTAIN OR CHECK THIS DEVICE COULD LEAD TO SERIOUS ACCIDENT OR INJURY

THE OPERATOR ASSUMES ALL RESPONSIBILITY AND RISK ASSOCIATED WITH THE USE OF THIS PRODUCT

ATTACHING THE DEBRIS BAG



1. Pull the debris bag down over the lip on the vacuum head. Placing the clip over the front decal and standing over the vacuum head will allow you to tighten the clip more easily.



2. Pull both strings away from the clip so that the bag is as tight as possible around the vacuum head, then pull both strings all the way down into the grooves of the clip.

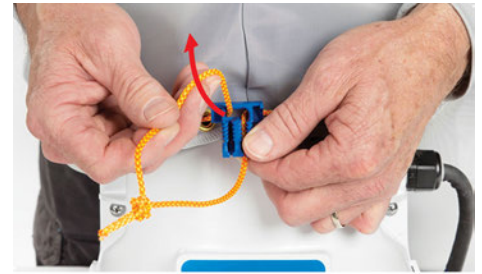

3. Tighten the bag again like this: Pull one string up and out to release it, then pull it down firmly into the groove of the clip. To release the bag for emptying, simply pull one string out of the groove, leaving the second string in place.

Hammer-Head bags are all handmade here in the USA from chemical resistant materials and feature a no-slip cleat/string attachment and color-coded tags for quick identification. They are reusable and with proper care will provide months of professional service. Bags should be stored clean and dry, and you should avoid dragging or scuffing them on the pool bottom, the pool deck, coping or any other rough surface. Bags can be punctured by sharp objects such as twigs, sticks, rocks, or glass. Please use care when vacuuming to prolong the life of your debris bag. Remove the bag before driving to your next pool. Transporting the Hammer-Head unit on the back of your vehicle while the debris bag is on the vacuum head will shorten the bag's life.

The best way to clean a Hammer-Head bag is to turn it inside out. Shake the debris out of the bag and rinse with a garden hose if necessary. Because of the fine debris it picks up, turning inside out and rinsing is the best way to clean the HH1510 Volcano bag.

CHOOSE THE RIGHT BAG FOR THE JOB

HH1502 COARSE BAG "THE HURRICANE"

SUGGESTED USE: Heavy debris where a second cleaning is a given - Spring clean-ups and start-ups, too. Also comes in an XL size as part number HH1502XL (46" long). True micron rating: 800

HH1506 STANDARD BAG

SUGGESTED USE: Best for larger debris and coarser sand and gravel particles. Also comes in an XL size as part number HH1506XL (46" long). True micron rating: 200

HH1508 SUPERFINE BAG

SUGGESTED USE: Smaller and larger debris, dust and fine sand. Use this bag when the pool is mostly clean. Good everyday bag to use once the pool is up and running normally. Also comes in an XL size as part number HH1506XL (46" long). True micron rating: 150

HH1510 ULTRAFINE BAG "THE VOLCANO" (patented)

SUGGESTED USE: Use this bag for special cleanup and when the pool is mostly clean. Patented, no-leak design. Tested to pick up approximately 95% of fire ash and DE powder. True micron rating: 75

MORE ABOUT DEBRIS BAGS: *KNOW YOUR MICRONS*

You can't see a micron with the naked eye, but filtration is measured, talked about, and bragged about in microns. So, what is a micron? A micron is one millionth of a meter, or approximately .00003937 inches. Micron ratings are also absolute or nominal. Absolute micron ratings mean that the filter media will filter out 90% of particles below that micron size. Nominal micron ratings mean that the filter media will retain particles but not to any percentage greater than 50%.

To put it simply, the smaller the micron number, the finer the filtration. As debris goes, any particle below about 40 microns is smaller than the human eye can easily see.

Average diameter of a human hair: 70 microns

White blood cells: 25 microns

Talcum powder: 10 microns

Red blood cells: 8 microns

Bacteria: 2 microns

What does this mean? When a filter or bag manufacturer claims they have a 3 or 6 micron rating, you should ask yourself: Will this really filter blood cells, or actual bacteria? We don't think so either. The truth is, there isn't much truth to micron ratings because there is no standardized testing for these ratings. Each manufacturer can apply any rating based on their own testing. What is really important to you, the service manager or maintenance technician, is the real-world performance of these filter media, and of course, the Hammer-Head debris bags. Hammer-Head bags are so popular, they are even used by owners of other vacuums. The bottom line: Don't believe every micron claim you read. With no industry standard, the only true test is the real-world test you perform yourself.

GENERAL HAMMER-HEAD VACUUMING AND OPERATING PROCEDURE

1. Roll the cart up to the pool with the power switch towards the water.
2. Slip your pool pole onto the yoke assembly, remove the bungee cord strap, unwrap a few coils of power cord from the cart, and set the vacuum head down on its wheels on the pool deck.
3. Attach and tighten the debris bag. (See ATTACHING THE DEBRIS BAG in this guide).
4. Lift the vacuum head unit and lower into the water.
5. Turn on the power switch and begin vacuuming. Avoid vacuuming over the debris bag. Do not let the debris bag drag on the pool floor, as this can damage the bag and make it unusable. The vacuum head should always be supported on the two large wheels. Vacuuming pool steps with the vacuum head hanging off the step will put unnecessary stress on the vacuum head body and wear it out prematurely.
6. When vacuuming the pool is complete, lift the head fully out of the water upside down (wheels up, debris bag down). Set the vacuum head down on the deck on its wheels and turn off the power switch. Avoid setting the vacuum head down on the front decal, this will wear out the head prematurely. Avoid snagging the bag on the pool edge, dragging it on the pool deck, or setting the vacuum on top of the bag, as this can damage the bag.
7. Remove the bag. Turn it inside out to empty it. You can also hose it off to clean it fully before the next use.
8. Remove the pool pole. Leaving the vacuum head on the deck, coil the cord back onto the cart in large loops. Do not coil tightly. Remove any twists in the cord as you replace it on the cart.
9. Place the vacuum head back on the cart rests and secure with the safety bungee for transport. We do not recommend transporting the unit with chemicals in the accessory tray. We do not recommend transporting the unit with the debris bag on the vacuum head, as this can damage the bag and make it unusable.
10. We recommend using 12 volt deep-cycle marine batteries with all Hammer-Head units. Marine batteries should be charged EVERY DAY on an automatic charger with a minimum charging rate of 6amps and a maximum of 10amps. **DO NOT TRICKLE CHARGE YOUR MARINE BATTERY.** Marine batteries should always remain on an automatic charger when not in use. This will lengthen the life of the battery and ensure maximum vacuum time per day.

UNDERSTANDING THE SMART (BLACK) SWITCH (HH1062)

The HH1062 Smart Switch was developed by Hammer-Head to add convenience, control, and protection to your Hammer-Head Resort or Service unit. The internal circuit board monitors amperage and voltage levels to save the motor from burnout during a jam, or while running out of the water. It has a built-in protection from reverse polarity wiring, as well as an auto shut-off feature when out of the water. These are some of the key features and functions:

- **FULL POWER MODE** — **press ON once** — This turns on the motor with 100% power. The GREEN indicator light around the switch will remain solid. There may be a brief delay before the motor runs, and you may see a temporary flashing blue light and/or hear a sound before the light turns green. The blue light flash before startup is a diagnostic light and does not indicate a problem. **SOLID GREEN LIGHT = FULL POWER MODE**
- **LOW POWER (BATTERY SAVER) MODE** — **press ON, OFF, ON** — This turns on the motor with 80% power. The green indicator light will flash. In this mode the motor runs slower, conserves power, and can extend your run time and battery life. **FLASHING GREEN LIGHT = LOW POWER MODE**
- **AUTO REVERSE MODE** — The motor can detect changes in resistance on the propeller. If the prop becomes jammed and cannot spin, the motor will quickly reverse itself three times to clear the jam. If it cannot clear the jam and spin freely, the switch will shut down the motor and you will see a red flashing light.
- **SAFETY (SHUT DOWN) MODE** — The motor has shut down because it cannot spin freely. The lights will flash RED. Turn off the switch, pull the vacuum out of the water, and remove the obstruction. Return to vacuuming by activating the switch in either full speed or low speed mode. **FLASHING RED LIGHT = SHUT DOWN MODE**
- **WIRING FAULT MODE** — The motor will not run and the lights will flash RED AND BLUE. This indicates that there is a short circuit in the wiring. Inspect the wiring and battery for faulty connections. A short in the blue floating power cord may be caused by a kink or twist. **FLASHING RED AND BLUE LIGHT = WIRING FAULT MODE**



1. In FULL POWER mode - PRESS ON - the lights around the switch will be solid green.
In BATTERY SAVER mode - PRESS ON, OFF, ON - the lights will flash green.



2. In SAFETY (SHUT DOWN) MODE the lights will flash red to indicate a motor shut down. Turn the switch off and clear the propeller of any obstruction. Restart.



3. In WIRING FAULT MODE the switch will flash red and blue (older models may flash red only). This indicates that there is a wiring and/or connectivity problem. Check ALL connections.

The HH1062 Smart Switch can detect low battery power levels and will not allow the motor to run if the battery is undercharged or has run out of power. If the motor stops shortly after being powered up, and the switch does not display any lights at all, CHECK ALL WIRING CONNECTIONS and BATTERY charge level first. Your battery may not have enough power.

HAMMER·HEAD®

MOTOR TROUBLESHOOTING GUIDE - BASIC

| PROBLEM | CAUSE | DO THIS |
|---|--|---|
| <p>MOTOR DOES NOT RUN AT ALL BUT BATTERY IS KNOWN TO BE GOOD, HAS A FULL CHARGE, AND IS BEING CHARGED DAILY AT A MINIMUM OF 6 AMPS</p> | <p>POWER NOT GETTING TO MOTOR DUE TO FAULTY SWITCH, BATTERY CONNECTIONS ARE BAD, OR THERE IS A BREAK IN THE WIRE</p> | <p>CHECK ALL CONNECTIONS FIRST!</p> <p>CHECK TO SEE IF 30AMP FUSE HOLDER IS PRESENT. CHECK THE FUSE.</p> <p>IF ALL CONNECTIONS ARE GOOD, THEN BY-PASS THE SWITCH AND WIRE THE HEAD DIRECTLY TO THE BATTERY - IF IT RUNS, THEN THE PROBLEM IS WITH THE SWITCH. IF IT DOES NOT RUN, THEN THERE IS A BREAK IN THE WIRE OR A MOTOR SHORT</p> |
| PROBLEM | CAUSE | DO THIS |
| <p>VACUUM RUNS STRONG BUT BATTERY DRAINS AFTER A FEW POOLS. THE NEXT DAY IT DOES THE SAME THING.</p> | <p>BATTERY PROBLEMS:</p> <ol style="list-style-type: none"> 1. BATTERY WATER IS LOW OR BATTERY IS OLD 2. BATTERY CONNECTIONS ARE WEAK OR CORRODED 3. UNDERCHARGING - BATTERY NOT GETTING FULL CHARGE OR IS NOT BEING CHARGED DAILY AT A MINIMUM 6AMP OUTPUT | <p>CHECK ALL CONNECTIONS FIRST!</p> <p>CHARGE BATTERY AT A MINIMUM OF 6 AMPS EVERY DAY. NO TRICKLE CHARGING!</p> <p>HAVE YOUR BATTERY CHECKED</p> <p>CHECK THAT YOUR CHARGER IS CHARGING. A FULLY CHARGED 12 VOLT BATTERY WILL TEST AT MORE THAN 13 VOLTS.</p> |
| PROBLEM | CAUSE | DO THIS |
| <p>SLUGGISH OVERALL MOTOR PERFORMANCE</p> <p>VACUUM DOES NOT RUN AS STRONG AS WHEN IT WAS NEW</p> <p>VACUUM IS GETTING SLOWER AND WEAKER EVERY DAY</p> <p>MOTOR RUNS INTERMITTENTLY</p> | <p>EXCESSIVE DEBRIS UNDER PROP</p> <p>BAD WIRING CONNECTIONS</p> <p>BATTERY PROBLEM (SEE ABOVE)</p> <p>INTERNAL COMPONENTS ARE WORN OUT</p> <p>SHORT IN POWER CORD</p> | <p>REMOVE PROP AND CLEAN DEBRIS OFF SHAFT</p> <p>CHECK ALL ELECTRICAL CONNECTIONS FOR HEAT. IF THEY ARE HOT WHILE THE VACUUM IS RUNNING UNDERWATER, REPLACE OR RESET BATTERY CONNECTIONS</p> <p>LOOK FOR HEAT! HEAT INDICATES POWER LOSS, WHICH DRAINS POWER AND SHORTENS THE LIFE OF THE BATTERY</p> <p>CONTACT HAMMERHEAD FOR SERVICE OR REPLACE THE MOTOR/ CORD ASSEMBLY</p> |

STANDARD (RED) SWITCH WIRING (HH1061 & HH1060)

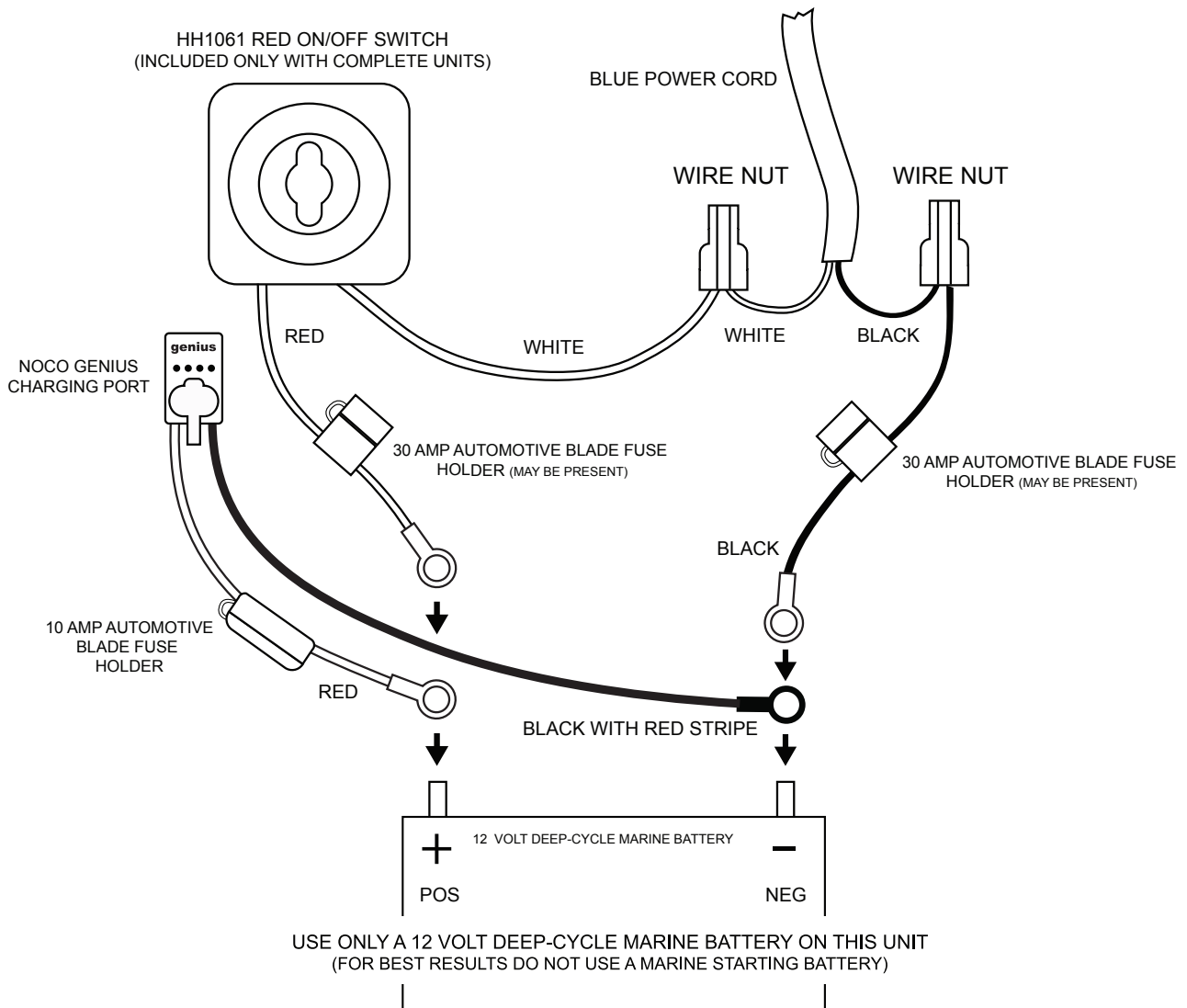

WE RECOMMEND DAILY AUTOMATIC CHARGING AT A MINIMUM 6AMP OUTPUT OR MAXIMUM 12 AMPS

POOR WIRING MAINTENANCE CAN LEAD TO SHORT CIRCUITS, DAMAGE, OR PERSONAL INJURY FROM HEAT AND POSSIBLE FIRE!
INSPECT WIRING CONNECTIONS DAILY

SAFE USE & MAINTENANCE

- **DO NOT** REACH INTO THE VACUUM HEAD WHILE THE PROPELLER IS SPINNING OR WHEN THE SWITCH IS IN THE ON POSITION.
- WHEN STOPPING THE UNIT, MAKE SURE THAT THE SWITCH IS FULLY IN THE OFF POSITION.
- **DO NOT** DRIVE YOUR VEHICLE WITH CHEMICALS IN THE CART ACCESSORY TRAY.
- IF USING THE MOUNT ASSEMBLY, LUBRICATE THE TOGGLE CLAMP LATCH, VERIFY THAT THE UNIT IS SECURE BEFORE DRIVING, AND ALWAYS USE THE SAFETY PIN.

- **DO NOT** ALLOW ANY PART OF THE FLOATING CABLE OR WIRING TO TWIST. REMOVE TWISTS AFTER EACH USE.
- **DO NOT** ALLOW ANYTHING OTHER THAN THE PROPER WIRES TO CONNECT, TOUCH, OR BRIDGE THE **POS(+)** AND **NEG(-)** BATTERY TERMINALS.
- **DO NOT** ALTER OR CUSTOMIZE THE WIRING OF THIS PRODUCT.
- **DO NOT** RUN DRY FOR MORE THAN 3 MINUTES

SMART (BLACK) SWITCH WIRING (HH1062)

STOP!
DO NOT OPEN THE SWITCH
 OPENING THE SWITCH WILL VOID THE WARRANTY

INSTALLATION

Use the included screws (4) to mount the switch to your cart frame as shown. Do not overtighten screws.



WIRING DIAGRAM

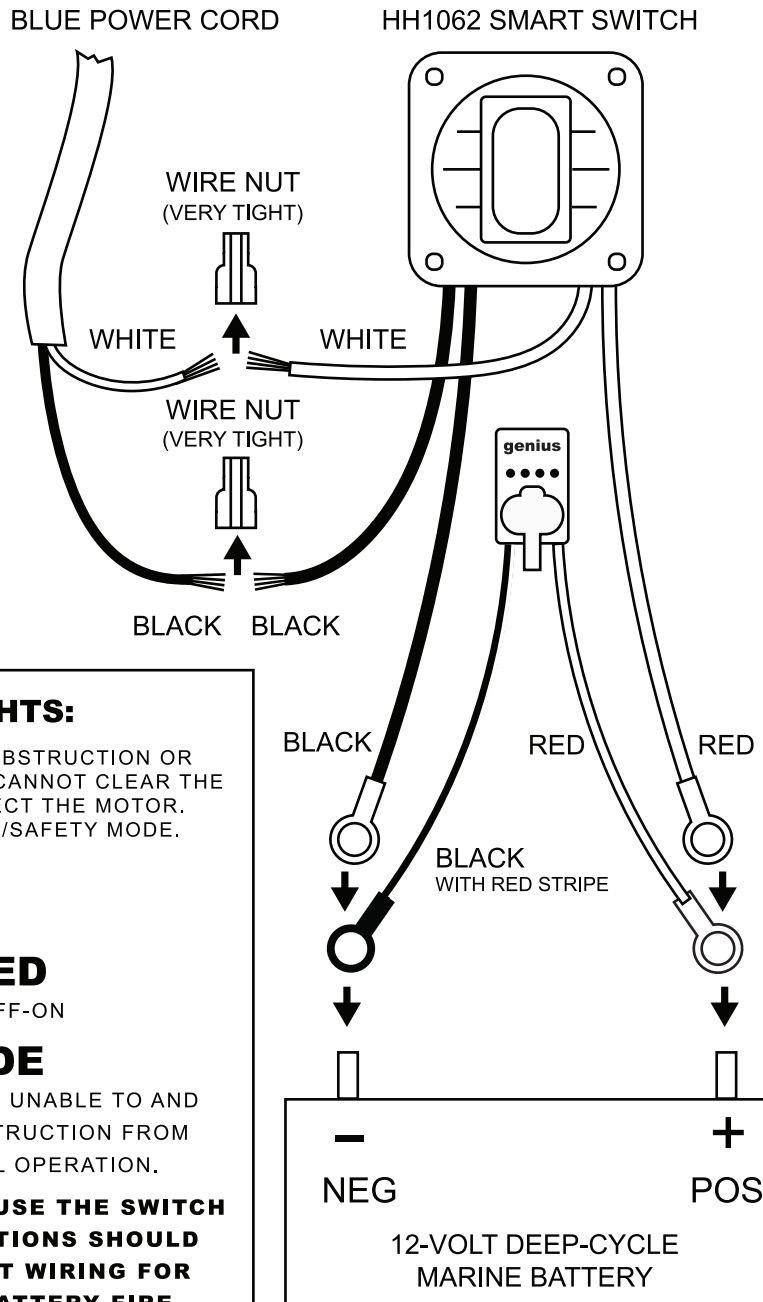

USE AND INDICATOR LIGHTS:

THE SMART SWITCH WILL ATTEMPT TO CLEAR AN OBSTRUCTION OR JAM BY REVERSING BRIEFLY UP TO 3 TIMES. IF IT CANNOT CLEAR THE OBSTRUCTION, IT WILL SHUT DOWN TO PROTECT THE MOTOR. THE SWITCH WILL FLASH RED DURING SHUT DOWN/SAFETY MODE.

GREEN = FULL SPEED

TURN SWITCH ON FOR NORMAL RUN

GREEN FLASH = LOW SPEED

FOR BATTERY SAVER MODE TURN SWITCH ON-OFF-ON

RED FLASH = SAFETY MODE

MOTOR IS ACTIVELY CLEARING THE JAM OR WAS UNABLE TO AND HAS SHUT DOWN. SWITCH OFF, CLEAR ANY OBSTRUCTION FROM THE PROPELLER, THEN SWITCH ON FOR NORMAL OPERATION.

WARNING: LOOSE CONNECTIONS WILL CAUSE THE SWITCH TO FLASH ERRATICALLY. WIRING CONNECTIONS SHOULD BE INSPECTED DAILY. FAILURE TO INSPECT WIRING FOR WEAR AND CORROSION COULD LEAD TO BATTERY FIRE AND/OR SEVERE PERSONAL INJURY.

LIMITED WARRANTY

PLEASE NOTE: Warranty on all NOCO products (NOCO charging ports, battery chargers, and all associated connections) must be submitted to NOCO directly and not to Hammer-Head Patented Performance, Inc. To find out more about the NOCO warranty policy visit <https://no.co/support/how-do-you-submit-a-warranty-claim>

Hammer-Head Patented Performance, Inc. offers either a limited 6 month or 12 month warranty on select serialized products. Your Hammer-Head serial number (where applicable) must be registered with Hammer-Head Patented Performance, Inc. to validate any warranty claim. The serial number located on any motor/cord assembly, complete cleaning unit, or complete vacuum head assembly is a record of the manufacturing date. If you do not register immediately after purchase, Hammer-Head Patented Performance, Inc. will offer a limited 6-month warranty from the date of manufacture. If you do register immediately after purchase, Hammer-Head will offer a limited 12-month warranty from the date of your registration according to the requirements as stated on the warranty registration card. This warranty covers manufacturing defects on complete units, motors, switches, mount assemblies, and cart frames. It does not cover wear and tear from normal use nor does it cover wearable parts. Wearable parts include debris bags, bearings, tires, wheels, cords, propellers, mount clamp latches, and all associated hardware. Hammer-Head units must only be used on electric current as indicated. Damage, defects, malfunctions, or other failures of the Hammer-Head arising from use on electrical currents other than recommended are excluded from this warranty.

Damage to Hammer-Head units or the parts thereof caused by negligent use or abuse while in the possession of the consumer are excluded from this warranty. If the consumer or anyone other than an authorized representative does repair or modifications to the Hammer-Head, Hammer-Head Patented Performance, Inc. can, at its discretion, void all warranty claims based on inspection.

All warranty claims must be submitted for inspection. The decision to replace or repair any part or product is the sole discretion of Hammer-Head Patented Performance, Inc., and cannot be made by anyone other than an official representative of Hammer-Head. Dealers, re-sellers, and distributors may not honor, extend, or make warranty replacements or repairs without the authorization of a Hammer-Head representative. Hammer-Head Patented Performance, Inc. assumes no responsibility for any warranties or representations beyond the expressed terms in this limited warranty. This limited warranty is valid and enforceable only in the United States of America on Hammer-Head products owned and operated normally within the United States of America.

This warranty may be subject to change without notice.

Hammer-Head Patented Performance, Inc
1250 Wallace Drive Unit D
Delray Beach, FL 33444
561-278-8992
info@hammerheadvac.com

