



"Global Pool Products is committed to engineering and manufacturing world class products in the pool industry"

TSUNAMI ASSEMBLY & INSTALLATION GUIDE



www.global-poolproducts.com



“Global Pool Products is committed to engineering and manufacturing world class products in the pool industry”

TSUNAMI SLIDE

TABLE OF CONTENTS

Introduction	PAGE - 3
Tsunami Post Installation Instructions	PAGE - 4
Maintenance Instructions	PAGE - 4
Tsunami Slide Placement/Stub Up	PAGE – 5
Tsunami Specification Sheets	Page – 6-8
Tsunami Assembly	PAGE –9-14
On Deck Mounting & Plumbing Instructions	PAGE – 15-16
Exploded View Reference Materials	PAGE – 17-20



“Global Pool Products is committed to engineering and manufacturing world class products in the pool industry”

INTRODUCTION

Global Pool Products is located in Mid-Michigan. Global Pool Products prides itself in manufacturing top of the line quality aquatic pool equipment and products. Global Pool Product’s key staff has over a century of combined industry experience and we take pride in each and every product that we build. Our products are made in the United States. Global Pool Products uses only the finest materials and processes to provide our customers with the highest quality products while still maintaining a price competitive edge.

The Tsunami is designed for use on in-ground residential swimming pools ONLY. The Tsunami must be properly assembled, installed, used, and supervised for proper use and operation to reduce the risk of serious injury and/or death.

Please refer to your local building codes and national building codes to be implemented prior to slide installation.

Before starting assembly, remove all packaging and materials from the boxes. Double check to make sure that nothing is left inside the boxes. Identify the parts and hardware utilizing the parts listed in this document. Examine all parts thoroughly prior to installation to avoid anything that may have been damaged in transit. A damaged part should not be used in the installation of this slide. Contact Global Pool Products if any parts arrived damaged. Proper assembly and installation of the Tsunami Slide is imperative. Not following the directions provided will void Global Pool Products Warranty and may affect the safety of the slide rider.

After installation of the Tsunami, please provide the slide owner with an owner’s manual, insist that warranty information be completed and sent to Global Pool Products, discuss proper use of the slide, and answer any and all questions regarding the safety of the slide.

**⚠️ NEGLECTING TO FOLLOW THESE INSTRUCTIONS AND THE OWNER’S
MANUAL MAY RESULT IN SERIOUS INJURY OR DEATH ⚠️**



“Global Pool Products is committed to engineering and manufacturing world class products in the pool industry”

POST INSTALLATION CHECKLIST FOR TSUNAMI SLIDE

Installer to review with slide owner upon completion of slide installation.

Examine:

- The flume for any apparent cracks or gashes.
- The ladder for sharp borders, snags, cracks, or gashes.
- All fasteners to make sure none are loose.
- The ladder for stability and connection to the flume.

- ✓ Pool water depth at the base of the slide should be at least 3' (914 mm) deep.
- ✓ The height of the slide flume exit above the water should be 20" (508 mm) maximum.
- ✓ The distance between the slide centerline and the edge of other pool equipment should be at least 3'6" (1067 mm).

MAINTENANCE INSTRUCTIONS

- A. Spray your Tsunami Slide down with water to wash away build up.
- B. Be sure that all connection points are tight. If not, tighten anchors as necessary.
- C. All polyethylene parts require little maintenance. Hose and wipe to clean.

Examine:

- The flume for any apparent cracks or gashes.
- All fasteners to make sure none are loose.
- The ladder and inner flume for sharp borders, snags, cracks, or gashes.



“Global Pool Products is committed to engineering and manufacturing world class products in the pool industry”

Tsunami Slide Placement/Stub-up Location

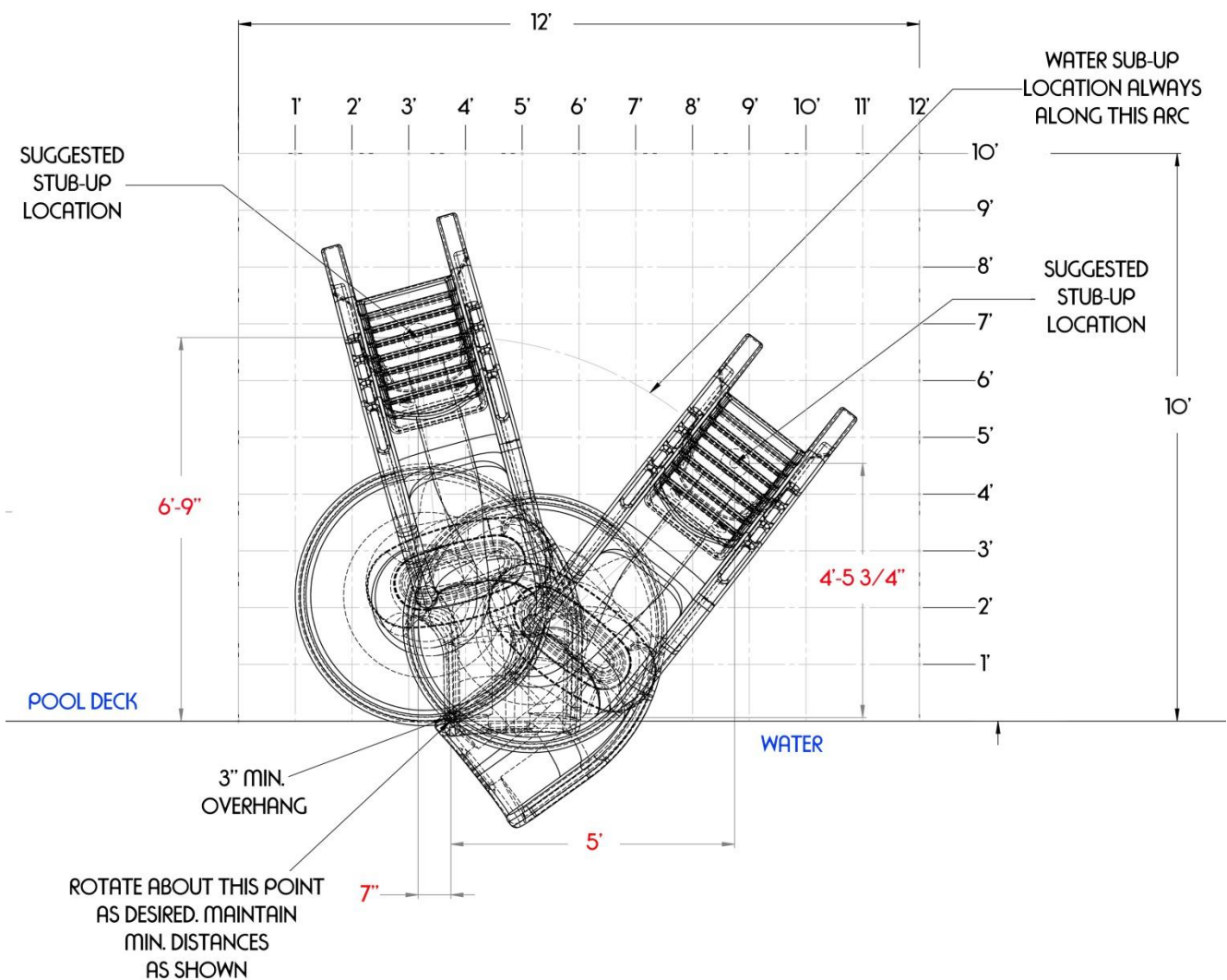

Global Pool Products
 1330 Pigeon Rd
 Bad Axe, MI 48413
 P: 989-269-5900 - TF: 866-712-0606
 Fax: 989-269-5902
www.global-poolproducts.com

Information contained in this document is proprietary and confidential to Global Pool Products and not to be reproduced without written consent from Global Pool Products.



“Global Pool Products is committed to engineering and manufacturing world class products in the pool industry”

Tsunami Slide Specifications

Product Numbers and Shipping Weights:

Model Number	Description	Shipping Weights
GPPSTS-GRAY	Tsunami – Gray Granite	240 lbs (108.9 kg)
GPPSTS-SAND	Tsunami – Sandstone Granite	240 lbs (108.9 kg)
GPPSTS-GRAY-LED	Tsunami – Gray Granite with LED Package	250 lbs (113.4 kg)
GPPSTS-SAND-LED	Tsunami – Sandstone Granite with LED Package	250 lbs (113.4 kg)

Broad Description:

The Tsunami Slide is a sturdy, durable, roto-molded slide with enclosed plumbing for a clean finished look. The Tsunami is available in Sandstone or Gray Granite finishes and has the option of an LED lighting package.

Utilization:

This slide is intended for use on in-ground residential swimming pools ONLY. Our multi point anchoring system allows the Tsunami to accommodate most geographical regions. The slide is rated for a maximum of 275 lb. (124 kg) for its riders.

Specifications:

- The ladder is enclosed with nine (9) coping style steps for a safe and easy climbing.
- The two (2) handrails are roto-molded into the ladder with two (2) optional widths for a comfortable climb for most riders.
- The slide runway has a twenty-four (24) inch wide seating area made of a thick, durable roto-molded plastic.
- The water delivery system is enclosed within the roto-molded ladder for a clean look. Water is delivered with a 1” PVC hose to allow maximum water coverage on the flume at 25 gpm.
- The Tsunami is anchored to the pool deck with ½” diameter stainless anchor studs with attaching hardware.

Global Pool Products
 1330 Pigeon Rd
 Bad Axe, MI 48413
 P: 989-269-5900 - TF: 866-712-0606
 Fax: 989-269-5902
www.global-poolproducts.com

Information contained in this document is proprietary and confidential to Global Pool Products and not to be reproduced without written consent from Global Pool Products.



“Global Pool Products is committed to engineering and manufacturing world class products in the pool industry”

Tsunami Slide Specifications

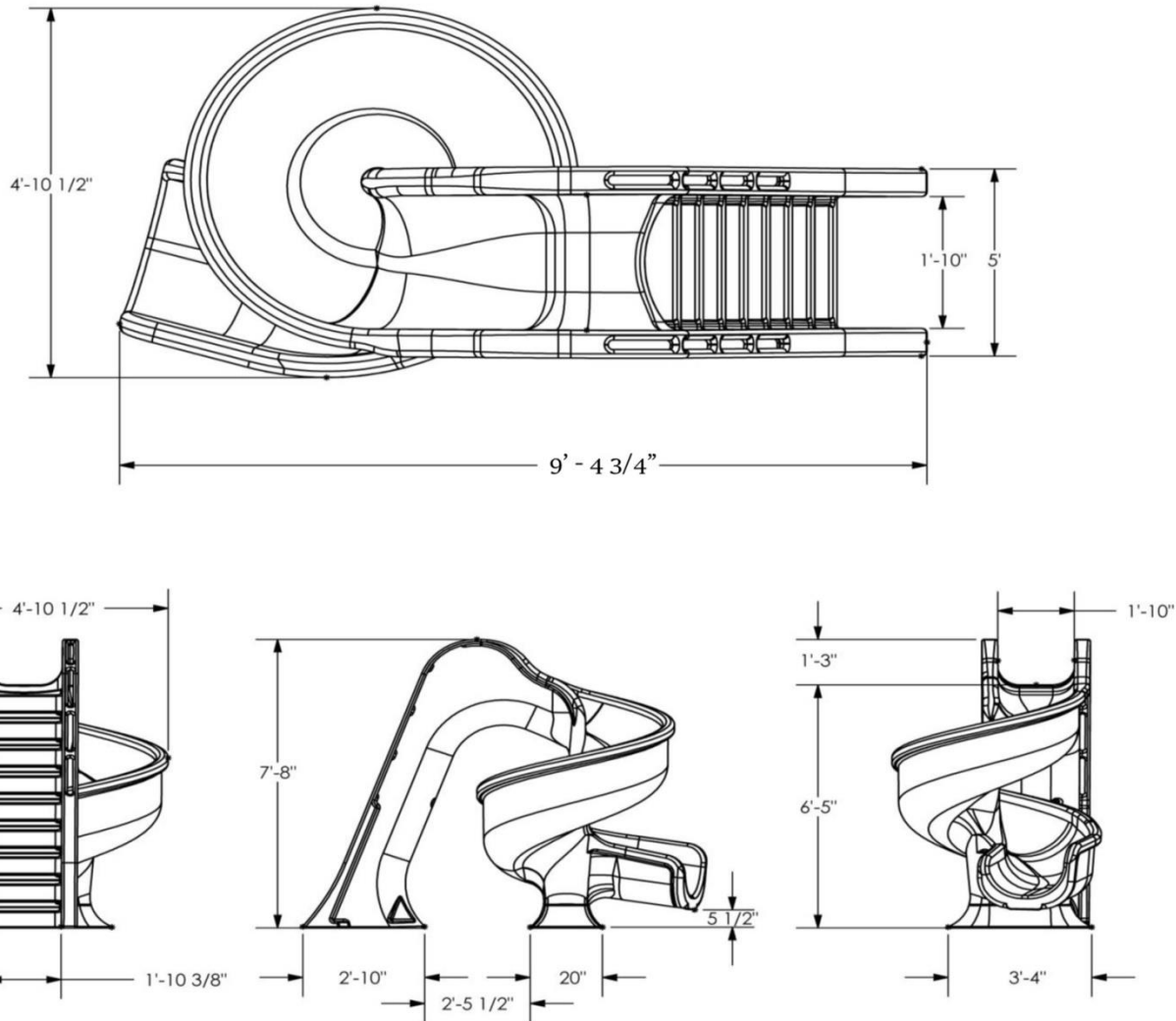

Global Pool Products
 1330 Pigeon Rd
 Bad Axe, MI 48413
 P: 989-269-5900 - TF: 866-712-0606
 Fax: 989-269-5902
www.global-poolproducts.com

Information contained in this document is proprietary and confidential to Global Pool Products and not to be reproduced without written consent from Global Pool Products.



“Global Pool Products is committed to engineering and manufacturing world class products in the pool industry”

Tsunami Slide Specifications

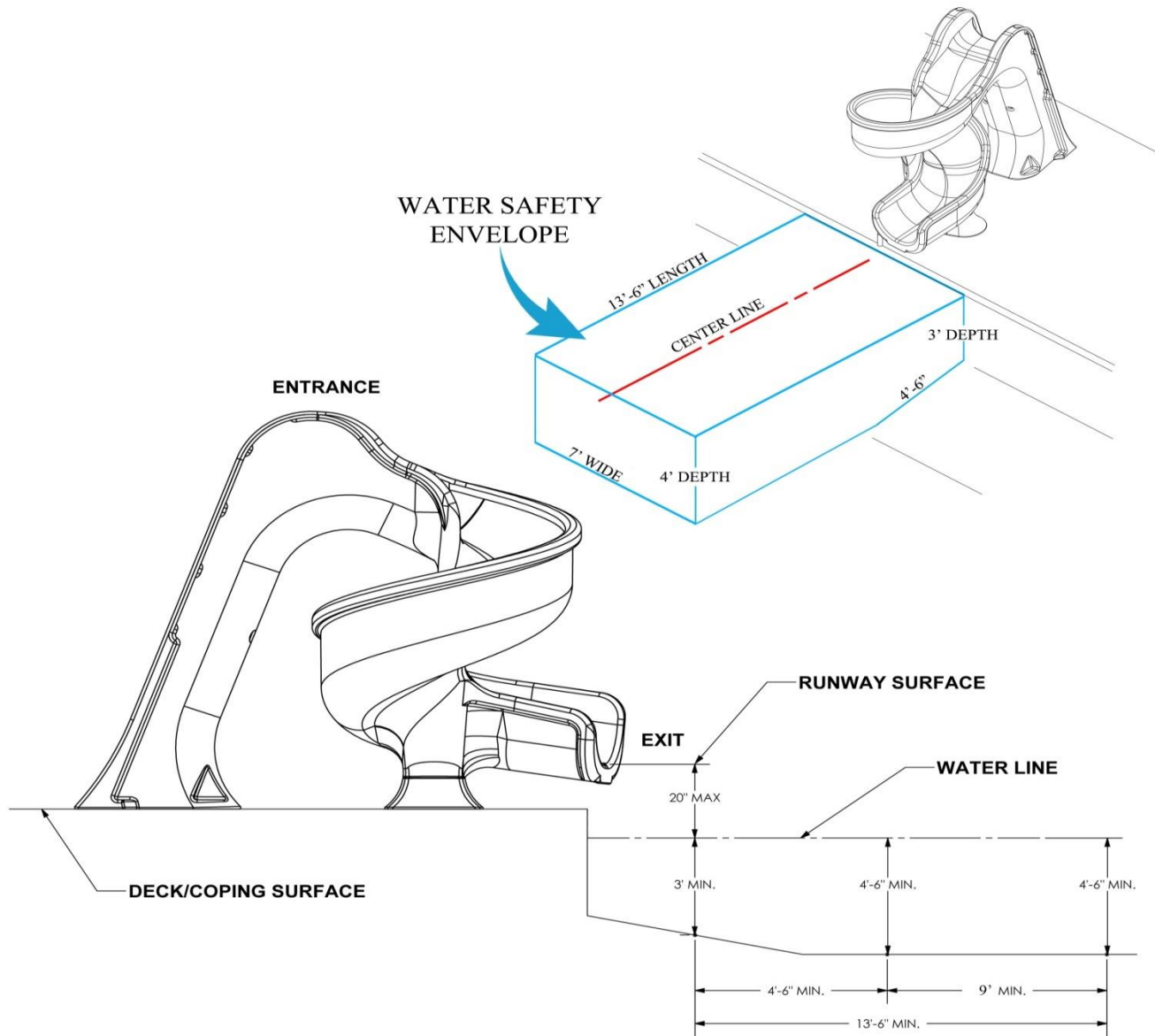

Global Pool Products
 1330 Pigeon Rd
 Bad Axe, MI 48413
 P: 989-269-5900 - TF: 866-712-0606
 Fax: 989-269-5902
www.global-poolproducts.com

Information contained in this document is proprietary and confidential to Global Pool Products and not to be reproduced without written consent from Global Pool Products.



“Global Pool Products is committed to engineering and manufacturing world class products in the pool industry”

TSUNAMI ASSEMBLY INSTRUCTIONS

Tools Needed:

- | | | |
|------------------------------|------------------------|----------------------------|
| 1. 3/16" Allen Wrench | 6. PTFE (Teflon) Tape | 10. 5/8" Deep Well Socket |
| 2. 7/32" Allen Wrench | 7. PTFE (Teflon) Paste | 11. 9/16" Deep Well Socket |
| 3. 9/16" Wrench | 8. PVC Primer | 12. Ratchet |
| 4. Anti-Seize (included) | 9. PVC Glue | 13. Ratchet Extension |
| 5. Phillips Head Screwdriver | | |

Included Hardware:

- | | | |
|--------------------------------------|------------------------------------|-----------------------------|
| (4) - 3/8" Hex Head Bolt – 2" | (20) - 3/8" x 1" Washer | (10) Concrete Anchors |
| (1) – 3/8" Button Head – 2 1/4" | (12) – Lock Washer | (4) – 3/8" Nut |
| (2) – 3/8" Acorn Nut | (2) – 3/8" Hex Bolts – 3" | (2) – 3/8" Stud – 2 3/4" |
| (2) – 3/8" Button Head Bolt – 1 3/4" | (1) – 54" Thick Foam-Rubber Gasket | (1) – 3/8" Button Head - 2" |
| (2) – 3/8" Stud – 2 1/4" | (1) – 1" PVC MPT Adapter | (2) – 3/8" Stud – 3" |
| (1) – 34" Foam-Rubber Gasket | (1) – 7'-6" PVC Flex Hose | (10) – Anchor Nut Caps |
| (6) - #4 Screws x 1/2" | (1) – Access Plate | (4) – 3/8" Hex Bolt – 3/4" |



Flume Base



Lower Flume



Lower Ladder



Upper Ladder



Upper Flume



“Global Pool Products is committed to engineering and manufacturing world class products in the pool industry”

Prior to the Start of Assembly:

- Utilize the cardboard that the slide shipped in as a barrier between your slide components and the surface that the slide is being assembled on to prevent any scuffs and scratches.
- Apply anti-seize to all threaded portions of the fastener hardware. This will aid in the assembly, resistance of corrosion, and prevents galling.
- Prepare all bolts with a lock washer and washer in the order as shown below.
***Excluding bolts used for the flume base to lower flume, only use the washer.**



- Tighten fasteners after all fasteners are threaded in place.

1. Assemble flume base to the lower flume by attaching them together with 4 of the 2” Hex Bolts.
(The components will need to be upside-down to complete this process)



2. Place the lower flume assembly with the base on the ground so the upper flume can be attached.
3. Install 34” foam-rubber gasket onto the lower flume where the gasket is about 1/8” below the flume surface and does not stick out past the upper flume portion.

Be careful not to damage the gasket when assembling the flumes together.

Set Lower flume on the spindle peg and rotate into position.



“Global Pool Products is committed to engineering and manufacturing world class products in the pool industry”



4. Attach the upper flume to the lower flume assembly, first with the one (1) 2" Button-head bolt on the upper attachment point and one (1) 2 1/4" Button-head bolt in the inner spindle.
5. This will align the underside holes. First, thread in the two (2) 3" Studs on the underside of the flume.

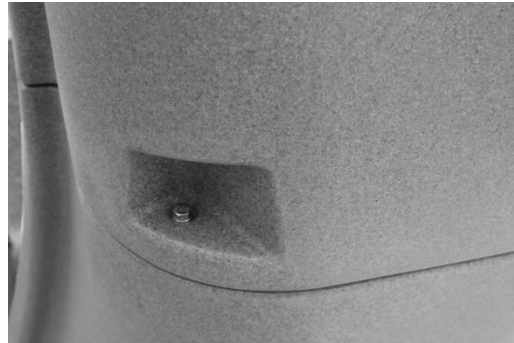

6. Secure the connections with two (2) 3/8" Hex Nuts.
7. Set aside flume assembly.
8. Plumb the Upper Ladder portion with the 1" MPT Adapter to the internal brass fitting (molded into the upper ladder portion of the slide) and the Flex Hose to the Male PVC Adapter.
 - a. Apply PTFE (Teflon) Tape to the threaded portion of the adapter (2 times around).
 - b. Apply PTFE Glue to the threads and screw into the brass fitting.
 - c. Apply PVC Primer to the Female end of the Adapter and to the Flex Hose.
 - d. Route the flex hose through the Upper Ladder portion of the slide, starting at the bottom 5" hole with the end that was primed.
 - e. Apply PVC glue to both the adapter and flex hose where they were primed.
 - f. Join the flex hose with the PVC adapter (push in and twist for good adhesion).
 - g. Allow for proper drying time before moving to the next step.



"Global Pool Products is committed to engineering and manufacturing world class products in the pool industry"

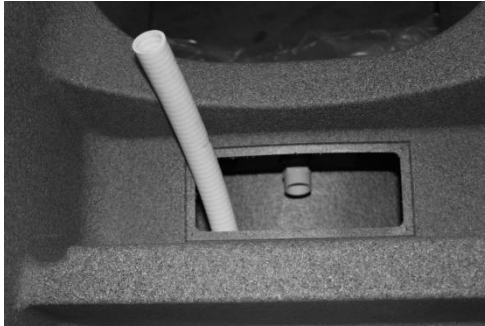

9. Insert two (2) 2 3/4" studs to the upper portion (lower 2 threaded inserts) of the Upper Ladder section of the slide and two (2) 2 1/4" Studs in the upper threaded holes.

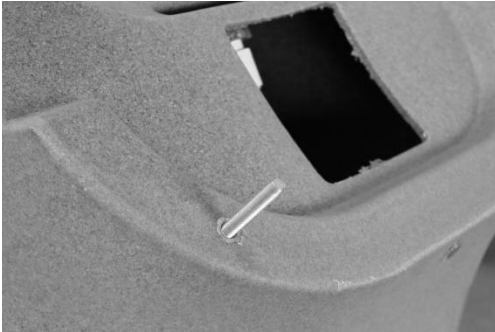

8. Route the flex hose and lighting wires (if this option is available on your slide) from the upper ladder section to the lower ladder section through 1 1/2" hole. Attach the upper ladder and lower ladder sections first by the using the two (2) 3/8" x 3" Hex Bolts at the 2 connection points, opposite of the ladder steps.

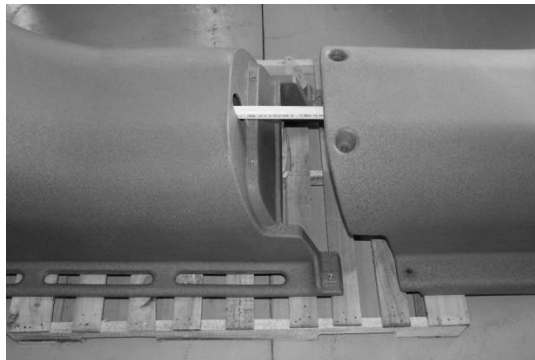

9. Lay the two ladder sections (ladder step side down) on a piece of cardboard on top of the pallet the slide shipped with for ease of assembly.
10. Attach the 2 sections with two (2) 1 3/4" Button Head Bolts at the handrail location and stand the ladder assembly upright.
11. Install 54" Thick Foam-Rubber Gasket to the upper connection point of the flume assembly to the ladder assembly.



"Global Pool Products is committed to engineering and manufacturing world class products in the pool industry"

12. Merge the Flume assembly to the Ladder assembly using the studs to aide in the connection.

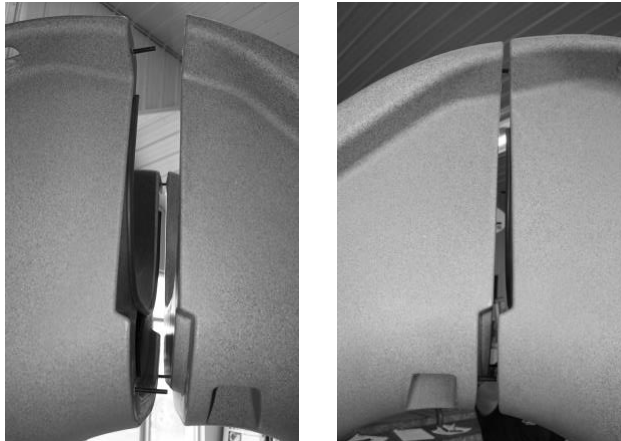

13. Attach the two assemblies with two (2) 3/8" acorn nuts at the upper connection point and two (2) Hex nuts at the lower stud location apply in this order: washer, lock washer then attach with 3/8" acorn nut or hex nut (depending on the location).



14. Finish securing the upper ladder to the flume assembly with the (4) 3/8" x 3/4" Hex bolts and 3/8" washers through the back access hole in the ladder section.





“Global Pool Products is committed to engineering and manufacturing world class products in the pool industry”

15. Pull the lighting wires and flex hose through the bottom 6” hole at the underside base of the ladder. Please consult with a local electrician to conform to your area’s codes and regulations on bonding and electrical hook-up.
16. Turn on the water to the slide to ensure there are no leaks at the connection point of the fitting to the brass insert as well as connection point of the flex hose to the PVC adapter.
17. Place the access panel over the opening in the ladder section and secure with the provided (6) #4 x1/2” screws using a screwdriver. DO NOT USE A POWER DRILL OF ANY SORT! This has the potential of stripping out the plastic and not allowing for a tight seal.

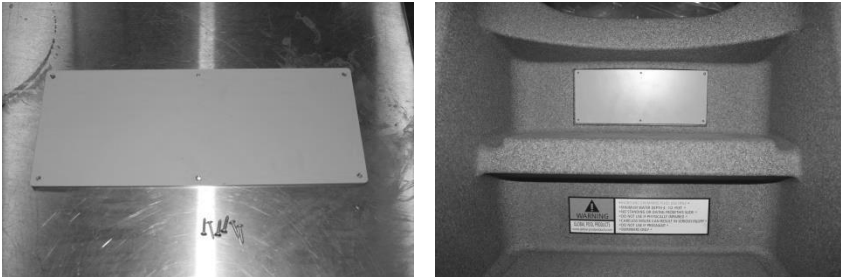

Optional Lighting Preparation

1. Install 1” conduit next to the water stub-up before concrete is poured.
2. Run the conduit outside of the concrete pool deck to either the pool equipment or junction box.
3. Refer to local building or electrical codes.

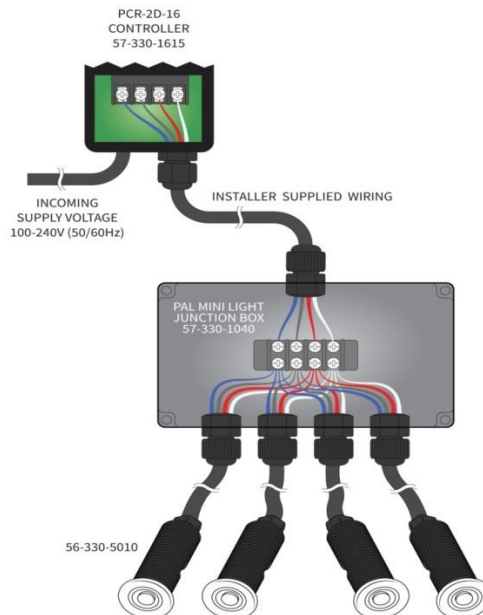



“Global Pool Products is committed to engineering and manufacturing world class products in the pool industry”

ON-DECK MOUNTING & PLUMBING INSTRUCTIONS

Required Tools

½” SDS Concrete Bit

Hammer Drill

Center Punch (Marking Tool)

Hammer

Shop-vac

4 ¾” Hole Saw (for garden hose hook-up option)

Included Hardware

½” Concrete Anchors

1. Place the assembled slide on the pool deck relative to the pool wall with the ladder side over the stub up location.
2. Check to ensure the exit of the flume clears all coping edges. The slide may be angled to your preference as long as the guidelines provided in Global Pool Product’s Placement Instructions are followed.
3. Once the slide is in its desired location and all guidelines are met use a center punch or other marking tool to indicate the mounting holes on the ladder and pedestal so marks are visible on the pool deck surface.
4. Remove the slide and any other objects that could obstruct the drilling of the anchor holes.
5. Using a Hammer Drill equipped with a ½” (13mm) SDS concrete bit, drill the marked holes to a depth of 3” (76mm). *Note: Mark the 3” depth on your SDS bit with some tape to prevent drilling anchor holes too deep. Ensure you are drilling the holes straight and perpendicular for proper holding and strength of anchor.*



6. Clear all anchor holes from any debris. Shop vac may be required if any debris gets in anchor holes.
7. Place slide back over anchor holes and assemble anchors with the included washer and nut so the so the top of the nut is flush with the anchor.
8. Plumb the slide to stub up location.



“Global Pool Products is committed to engineering and manufacturing world class products in the pool industry”

- a. Clean flex hose from slide and stub-up plumbing prior to assembling.
- b. Use PVC Primer & PVC Glue to adhere plumbing components from the slide and stub-up plumbing together



9. Drive all anchors through the slide anchoring holes.
10. Expand anchors by tightening the nuts three to five turns. When the anchor is set, remove the nut and install a lock washer, then retighten the nut to specified torque.

If installing pool slide as an aftermarket product and running the water from an alternate water source other than pool plumbing, you will need to:

1. Cut a 4 ¾” access hole in the lower ladder section of the slide to access the flex hose using the dimpled center mark in the rectangular area.



2. Assemble garden hose adapter and connect to water supply (garden hose)



“Global Pool Products is committed to engineering and manufacturing world class products in the pool industry”

ITEM NO.	PART NUMBER	DESCRIPTION	QTY.
1	FLUME	LOWER FLUME	1
2	BASE	SLIDE BASE	1
3	GPPBW375	WASHER	4
4	GPPS-375X2.25HHCS	BOLT 3/8" X 2 1/4"	4

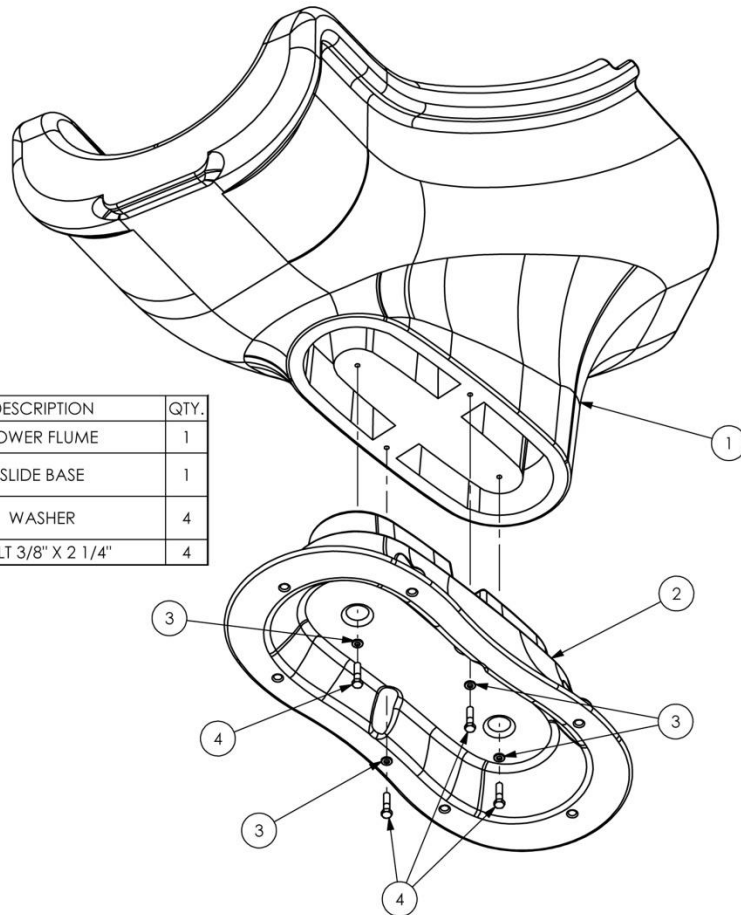



“Global Pool Products is committed to engineering and manufacturing world class products in the pool industry”

ITEM NO.	PART NUMBER	DESCRIPTION	QTY.
1	TSUNAMI UPPER FLUME	UPPER FLUME	1
2	GPPS-375X2BHCS	BUTTONHEAD BOLT 3/8" X 2 1/4"	1
3	GPPBSW375	LOCK WASHER	4
4	GPPBW375	WASHER	4
5	GPPS-N375	HEX NUT 3/8"	2
6	GPPS-S375X3	STUD	2
7	GPPS-375X2BHCS	BUTTONHEAD BOLT 3/8" X 2 1/4"	1

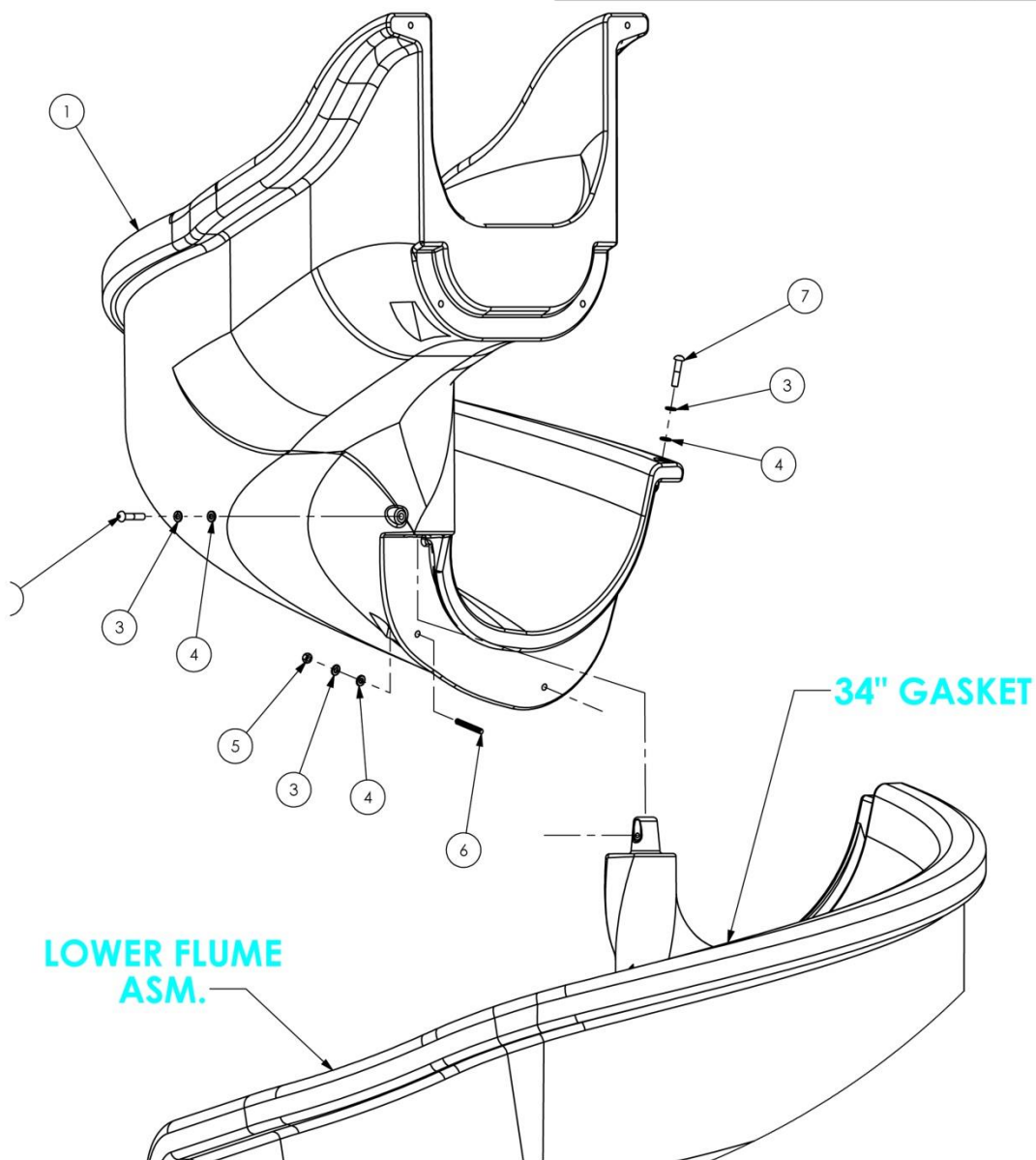



“Global Pool Products is committed to engineering and manufacturing world class products in the pool industry”

ITEM NO.	PART NUMBER	DESCRIPTION	QTY.
1	LADDER	UPPER LADDER	1
2	LADDER	LOWER LADDER	1
3	GPPBW375	WASHER	4
4	GPPBSW375	LOCK WASHER	4
5	GPPS-B375X1.75BHCS	3/8" X 1 3/4" BUTTON HEAD BOLT	2
6	GPPS-B375X3HHCS	3/8" X 3" HEX HEAD BOLT	2
7	GPPS-S375X2.75	STUD	2
8	GPPS-S375X2.25	STUD	2

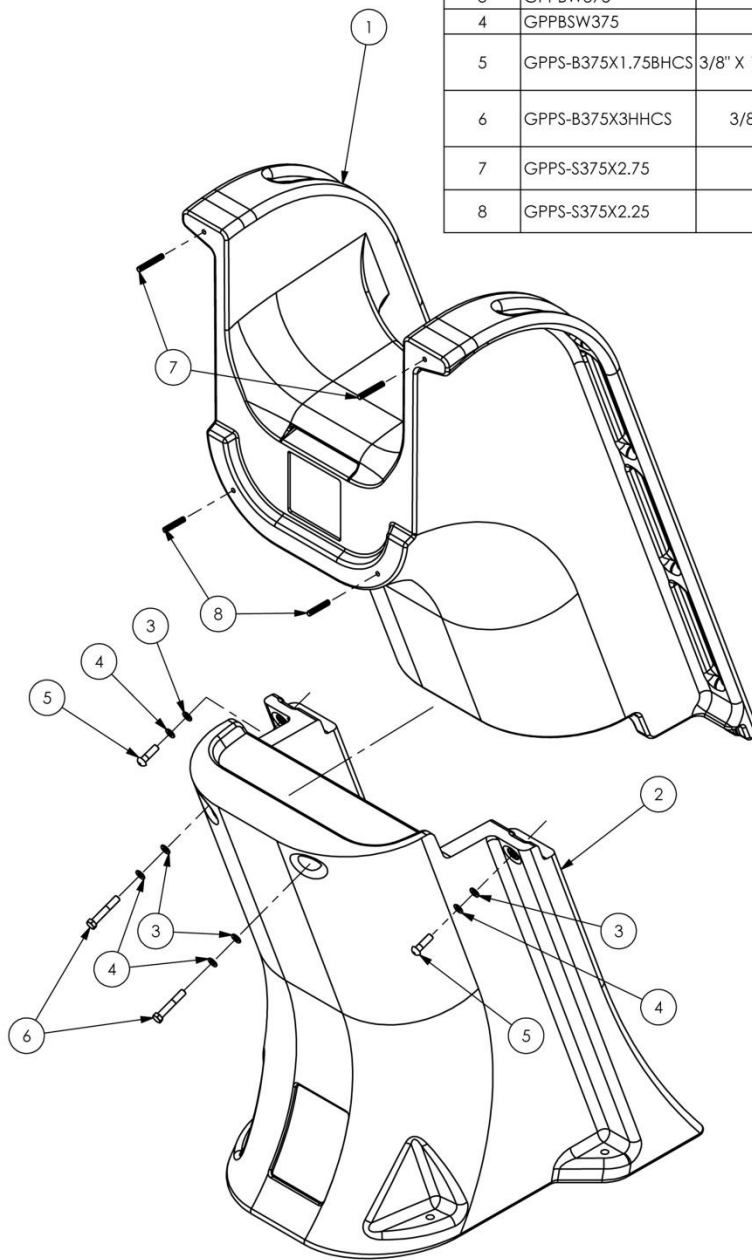

"Global Pool Products is committed to engineering and manufacturing world class products in the pool industry"

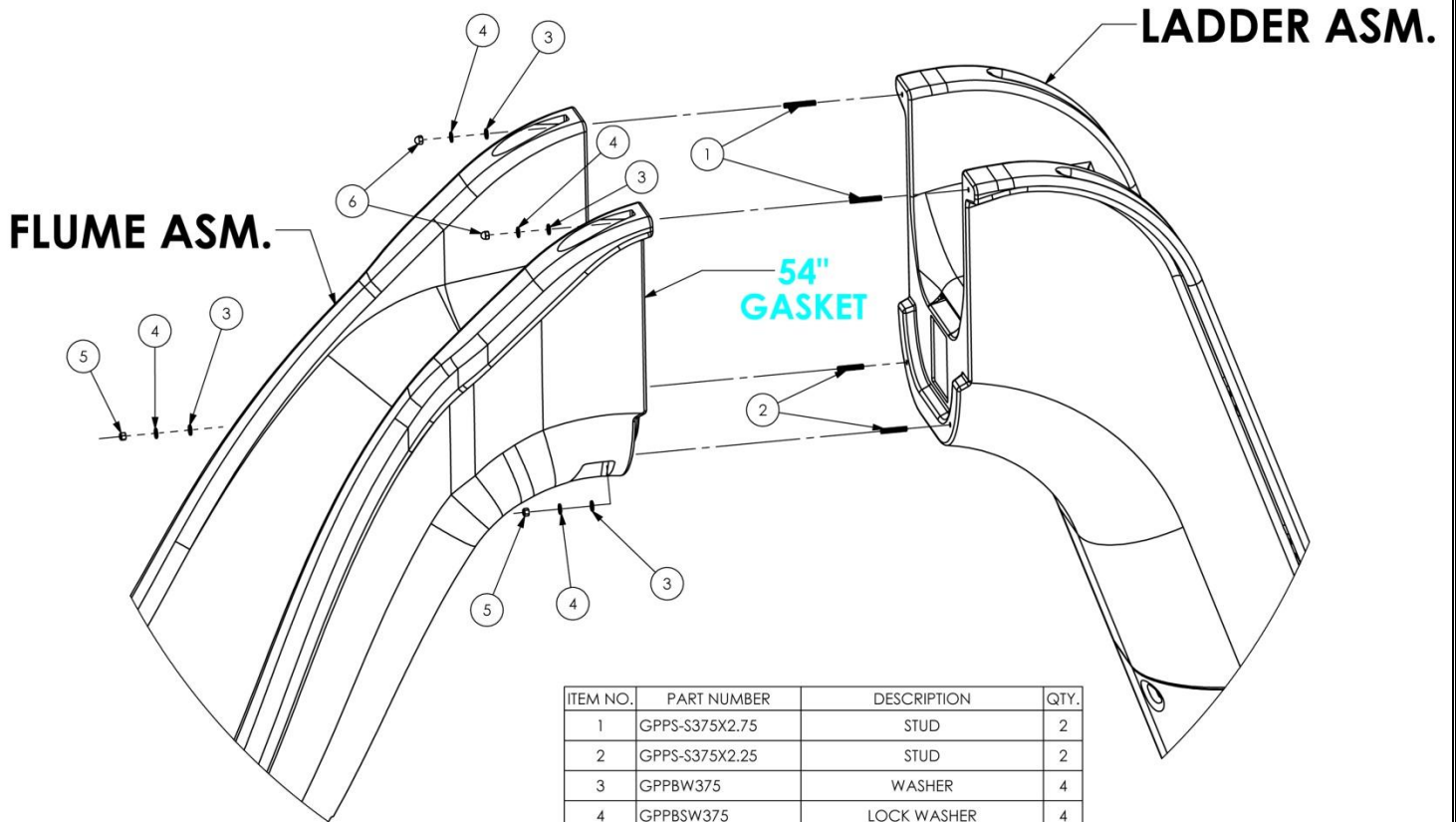

ITEM NO.	PART NUMBER	DESCRIPTION	QTY.
1	GPPS-S375X2.75	STUD	2
2	GPPS-S375X2.25	STUD	2
3	GPPBW375	WASHER	4
4	GPPBSW375	LOCK WASHER	4
5	NUT375-16-2	3/8" HEX NUT	2
6	GPPACNT375	3/8" ACORN NUT	2

*** Hardware attaches through access plate on back side of ladder section**

***GPP-B375x75HHCS 3/8" x 3/4" Hex Bolt QTY. 4**

***GPPBW375 WASHER QTY. 4**