

COMPLETE YOUR AOP INSTALLATION

By eliminating any possible off-gas, an MDV unit reduces the potential for corrosion or deterioration of pool accessories like a pool cover. It also allows the use of an "oversized" ozone generator to ensure a greater disinfection margin and larger reduction in chemical use. In each MDV a Granulated Activated Carbon (GAC) destruct cartridge destroys excess gas removed by the MDV.

MDV

When used with the AOP 25 the MDV prevents virtually all ozone bubbles from returning to the pool. It can prevent bubbles from gathering under the cover or inside plumbing.

MDV XL

The MDV XL should be used in all indoor, covered, and vinyl lined pools where there is an AOP 50 installed. It can also be used in outdoor applications to eliminate bubbles in your return flow.



MDV



MDV XL

INSTALLATION DIAGRAMS

DEL:AOP25

- Wall Mount Only
- Outlet Installs After Heater
- Injector Included
- 3/4 inch PVC Socket
- MDV Recommended

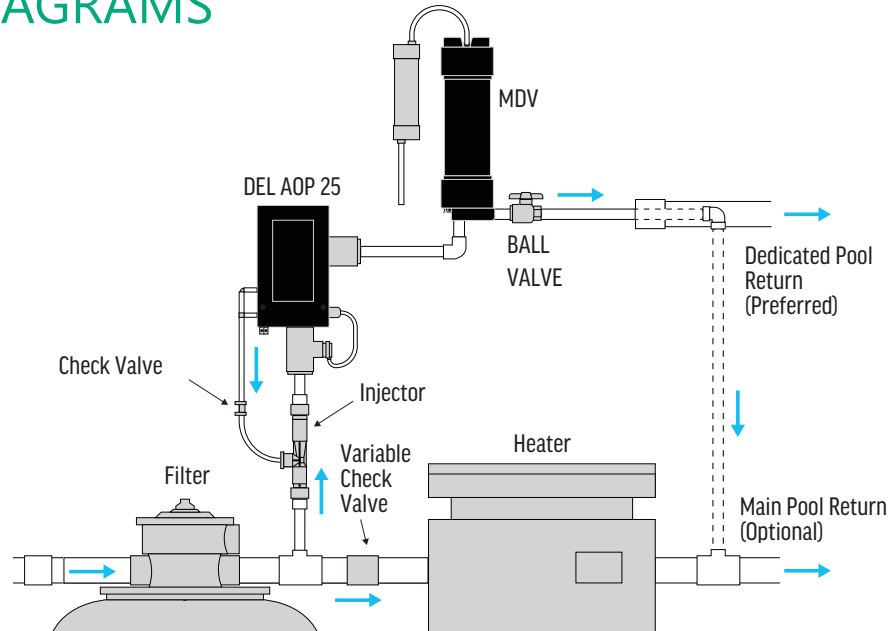

DEL:AOP50

- Ground or Wall Mount
- Install after Pump, Filter and Heater
- Variable Speed Check Valve and Injector Manifold are Built into the Unit
- 2" PVC Unions
- MDV XL Recommended

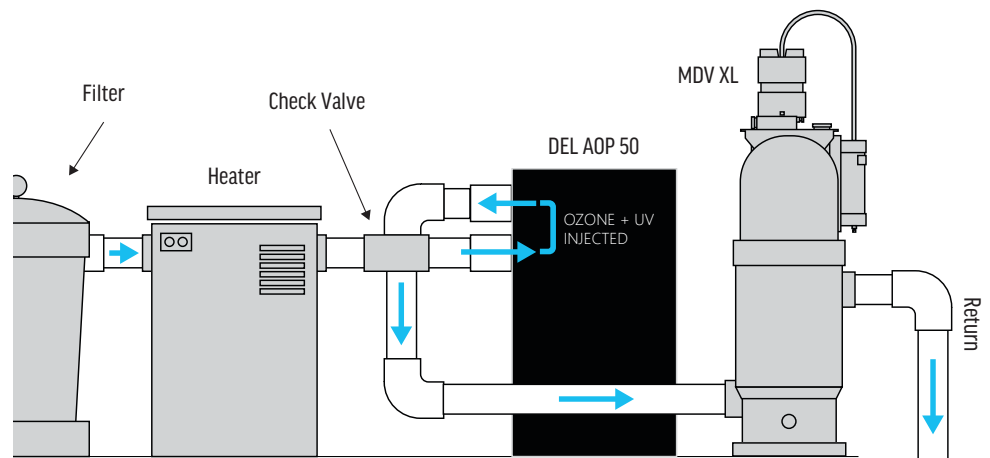



DESIGNING A SAFE MODERN POOL

Technology has come a long way, and so have pool sanitizers. By combining the best available technologies every pool can be crystal clear and absolutely safe.

DESTROY CHEMICAL RESISTANT BACTERIA

Some of the most dangerous pool contaminants are also resistant to chlorine and other chemicals. Organisms such as Cryptosporidium require long term exposure to high chlorine levels to be destroyed. AOP oxidizes these types of contaminants for a safer pool.

WORK WITH YOUR RESIDUAL FOR THE BEST PERFORMANCE

Chlorine and other chemicals are good at keeping pool water actively safe even when the pump is off. AOP is the best at micro-sanitizing the water. AOP even breaks down chloramines that increase demand and add to unpleasant pool smells. Working together, a residual and AOP create a complete modern pool system.

REDUCE CHEMICAL DEMAND

By allowing AOP to work at quickly oxidizing organic and inorganic compounds, chlorine is free to work better. This reduces the chemical demand and greatly reduces the amount of chemicals that have to be added to the water. Every pool can experience a reduction in chemicals and a reduction in the annual chemical costs.

DEL  **AOP** + **POWERclean**
ULTRA VS

Combine Powerful AOP Sanitizing With The First Chlorinator Designed For Variable Speed