

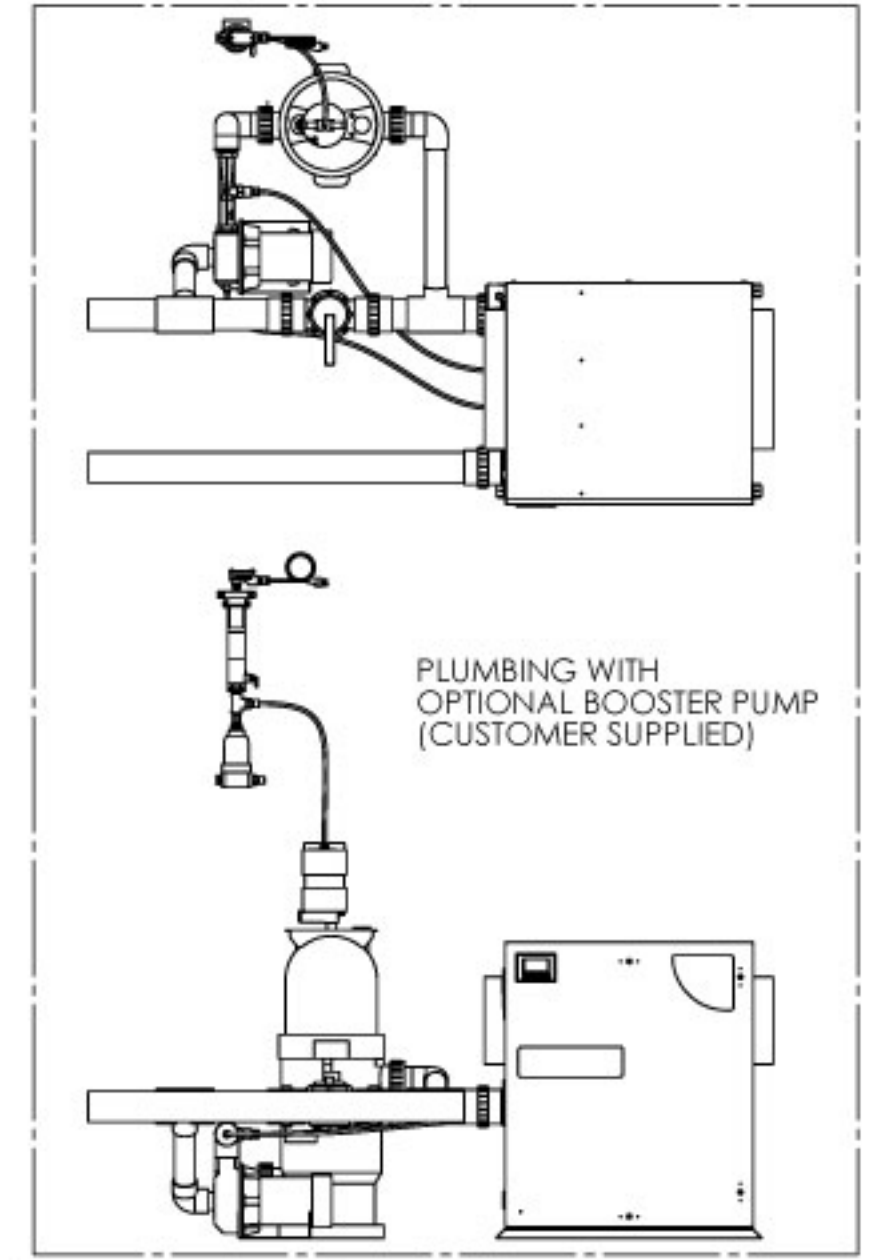

REVISIONS			
REV.	DESCRIPTION	ECN #	DATE
A	INITIAL RELEASE	NPD105	06/09/2021

SPECIFICATIONS	
MODEL	AOP-PRO-200DXX-XX
POWER	240 V / 5.5 A / 60 Hz
ENCLOSURE RATING	NEMA 12
AMBIENT OPERATING TEMP.	40 - 100 °F (5 - 38 °C)
OPERATING FLOW RANGE	65 - 200 GPM
MAXIMUM OPERATING PRESSURE	50 PSI
MAXIMUM WATER TEMP.	102 °F (39 °C)
APPROVALS	UL, NSF

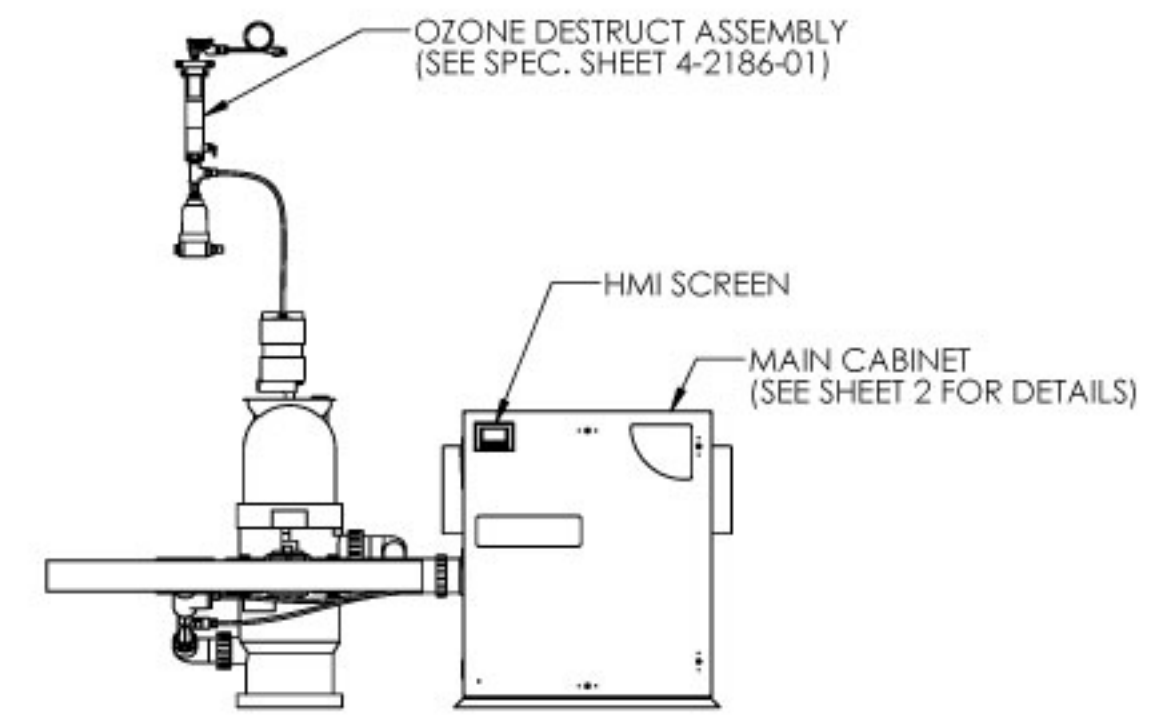
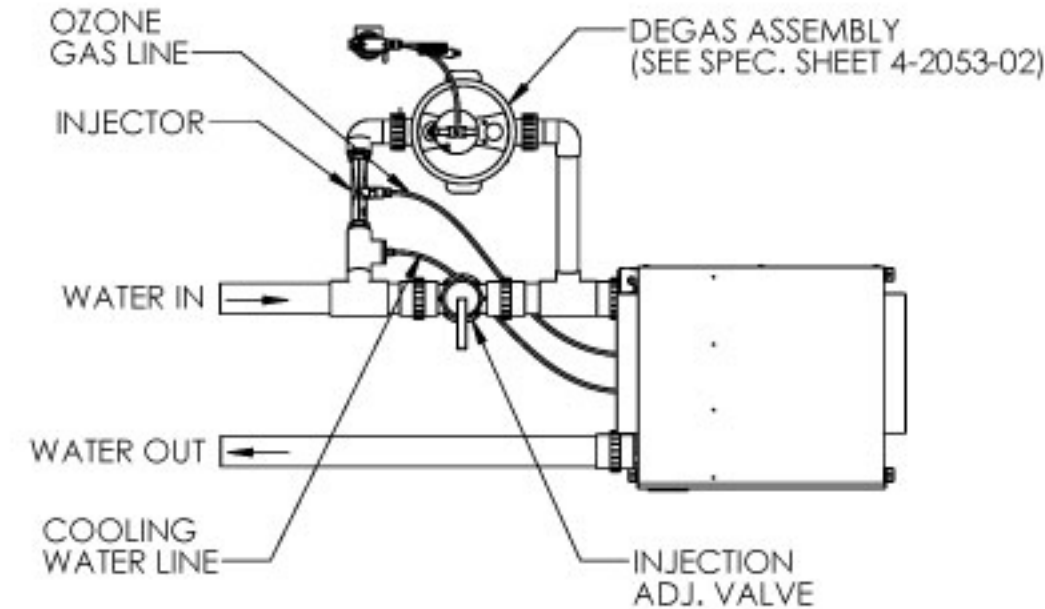

NOTES: UNLESS OTHERWISE SPECIFIED
 1. AOP-PRO-200D-01 MODEL SHOWN.
 2. PVC PIPE NOT INCLUDED.

PROPRIETARY AND CONFIDENTIAL
 THE INFORMATION CONTAINED IN THIS DRAWING IS THE SOLE PROPERTY OF CUSTOM MOLDED PRODUCTS. ANY REPRODUCTION IN PART OR AS A WHOLE WITHOUT THE WRITTEN PERMISSION OF CUSTOM MOLDED PRODUCTS IS PROHIBITED.

UNLESS OTHERWISE SPECIFIED DIMENSIONS ARE IN INCHES (mm) TOLERANCES: X ± .1 XX ± .02 XXX ± .010 ANGLES: ± 1°	DRAWING STATE:		 TITLE: SPECIFICATION, DWG, AOP-PRO-200DXX-XX	
	PROJECT R/ECN #:			
	ENGINEERING DESIGN	DATE		
	T.MOORE	6/9/2021		
ENGINEERING APPROVAL:		PART NO. 4-2658-06	REV A	
MATERIAL NA FINISH NA				
CAD-GENERATED DRAWINGS DO NOT MANUALLY UPDATE		SCALE: 1:22 DO NOT SCALE DRAWING	WEIGHT:	SHEET 1 OF 2