

CN-XL Series - Pool Heat Exchangers

The CN-XL series of heat exchangers was designed specifically for commercial sized swimming pools. They provide a simplified and practical means of indirectly heating both commercial and municipal pools. The vast majority of hotels, YMCAs, municipal arenas, community centers, universities/colleges and condominiums already utilize boilers for makeup air and domestic water heating. Typically these boilers are oversized and are not in operation on a continuous basis even during the winter months. Utilizing this excess capacity also ensures a more continuous operation of the boiler which reduces cycling.

The CN-XL series heat exchangers are available in capacities ranging to 3,000,000 Btu/hr and are therefore suitable for large Olympic size swimming pools. In addition to providing sufficient surface area to facilitate high rates of heat transfer these units are also designed to handle a flow rate of 400 USGPM of pool water with a pressure loss of only 3.2 psi (7.5 feet water).

Please contact us with the design parameters so that we can size a suitable unit and provide a data sheet with the design criteria and flow characteristics - as these are engineered products it is important that they are correctly sized for your application. .



Applications
 Large Scale Pools
 Hot Tubs
 Geothermal Pool Heating
 Solar Pool Heating

* Removable tubestacks for easy cleaning

Features

- High Heat Transfer Capacities
- Rugged Design
- Resistant to Corrosion from Both Chlorinated and Salt Water Pools
- Removable Tubestacks Enables Easy Cleaning
- Quick Delivery from Stock



Standard Material

Tube side (Pool Water): Cupro Nickel
 Shell Side (Boiler Water): Cast Iron Steel

Maximum Pressure

Hot Side: 90 psig
 Cold Side: 90 psig

Maximum Temperature

250 °F

Approvals

CRN



Manufactured under ISO 9001-2008 quality guidelines

Made in England

CN-XL Quick Reference Chart (based on boiler water temperature 180°F)

Part Number	Pool Capacity USG	Pool Water Flow GPM	Boiler Water Flow GPM	Boiler Capacity BTU/Hr	Connections	
					Hot	Cold
CN650	60000	127	31.7	650,000	1 1/2" NPT	3" NPT
CN1000	120000	222	54.5	1,000,000	2" NPT	3" Flange
CN1500	200000	330	84.5	1,500,000	2 1/2" NPT	4" Flange
CN2000	240000	500	126	2,650,000	3" NPT	5" Flange

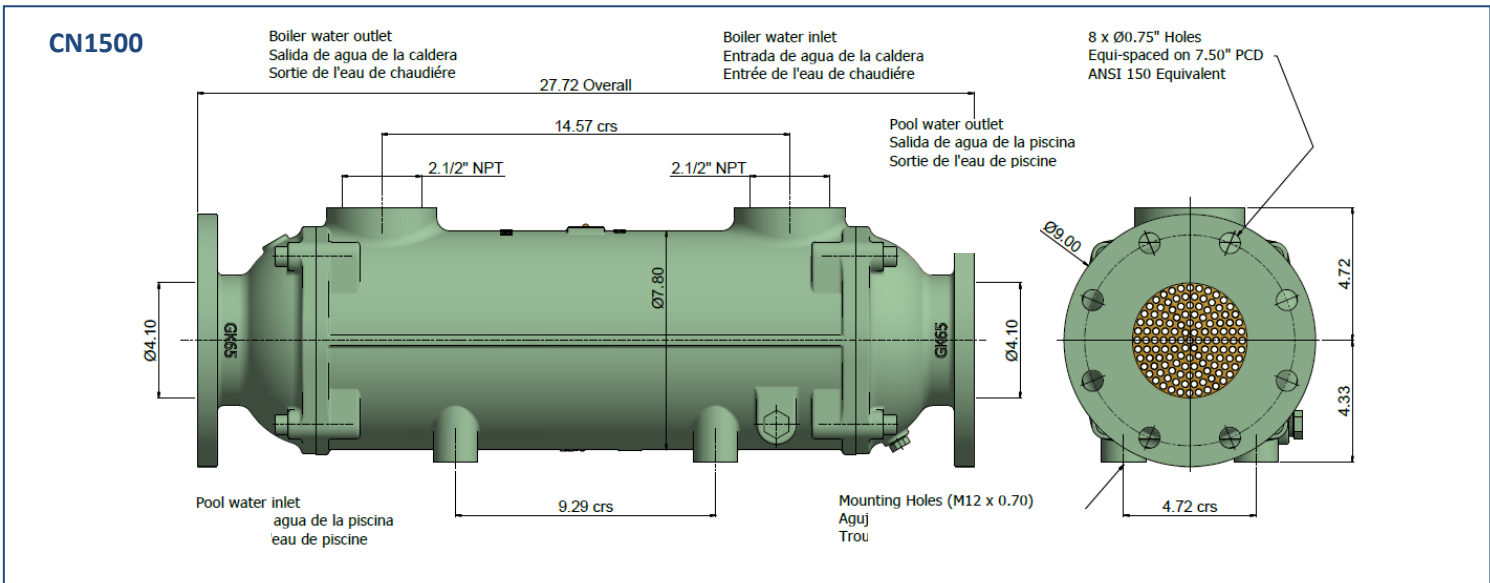
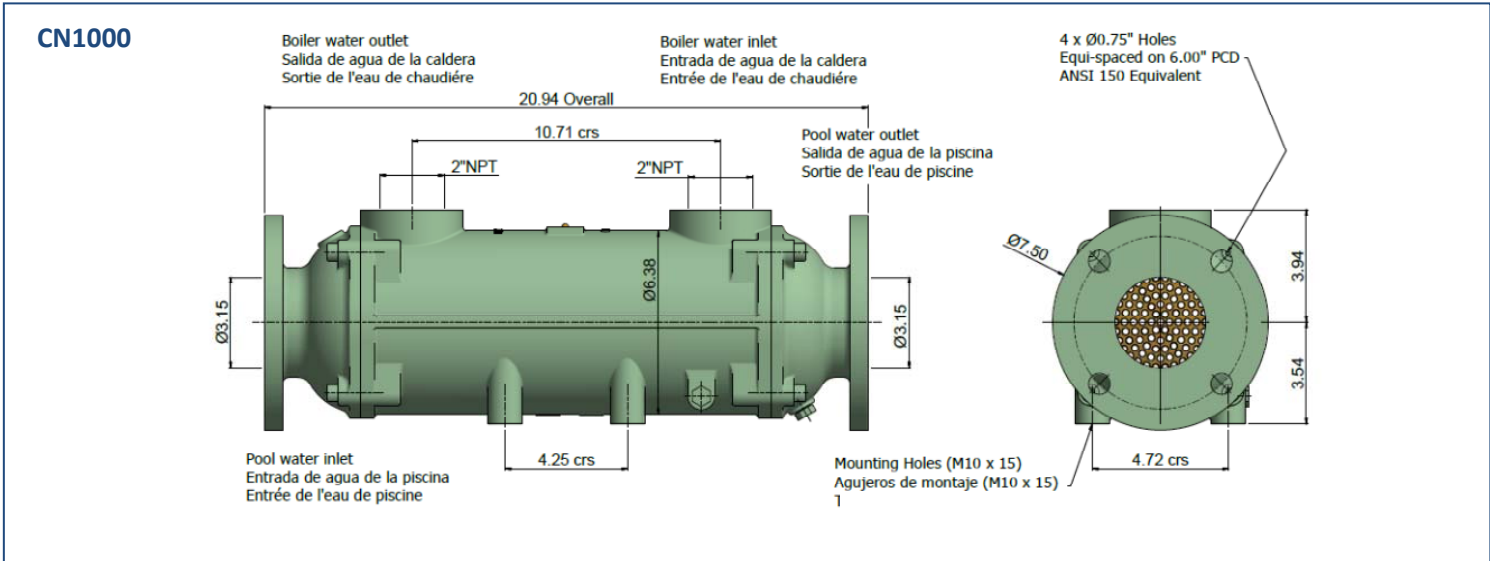
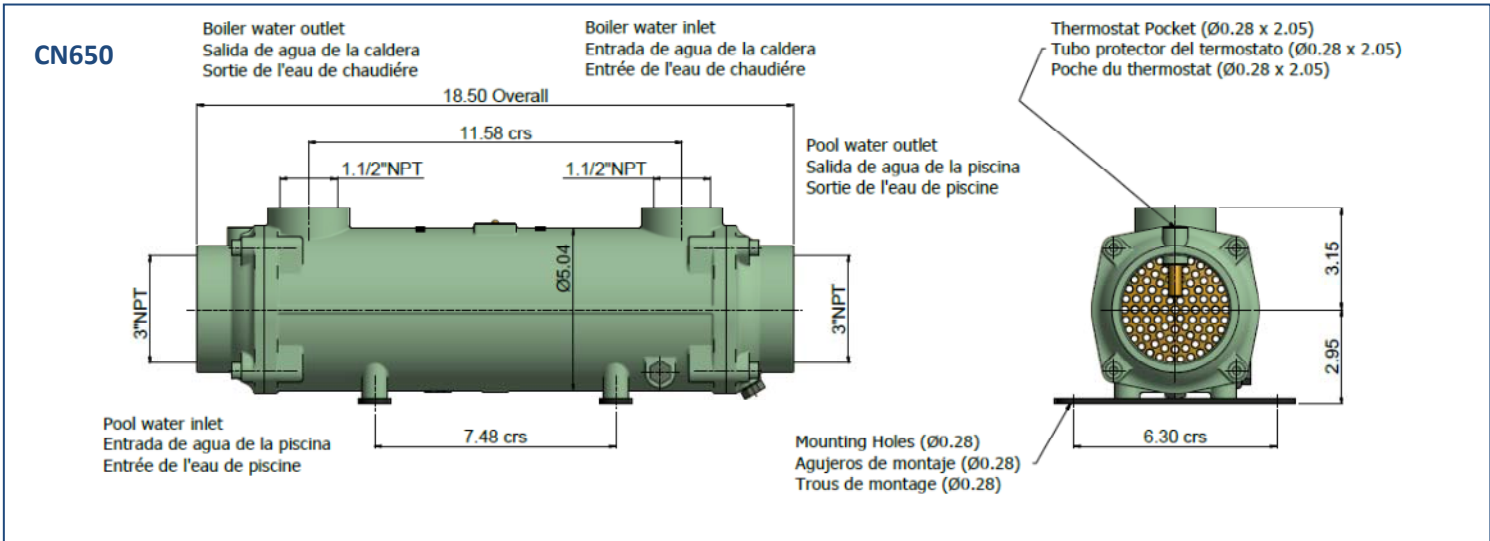

Stocking Distributors for North America



Toll Free: 1-877-751-9414
Web: valutechinc.com
eMail: info@valutechinc.com

Dealer: