

GENERAL NOTES:

1. MEDIA NOT INCLUDED WITH FILTER
2. CONCRETE SLAB TO BE DESIGNED BY OTHERS
3. FILTER MADE FROM HIGH STRENGTH FIBERGLASS AND RESINS
4. FILTERS HAVE UV STABILIZED CLEAR COAT
5. ALL INTERNAL COMPONENTS ARE CONSTRUCTED OF SCHEDULE 80 PVC.
6. MANHOLE CAN BE LOCATED ON EITHER SIDE OF FILTER. PLEASE SPECIFY AT TIME OF ORDER.
7. SAND DRAIN AND WATER DRAIN ARE PLACED ON THE SAME SIDE AS THE MANHOLE.

FILTER DATA

TOTAL SURFACE AREA:	46 SQ. FT.
MAX WORKING PRESSURE:	50 PSI.
MAX FLOW RATE:	20 GPM / SQ. FT.

MEDIA REQUIREMENTS

SAND:	5,400 LBS
GRAVEL:	3,100 LBS

WEIGHTS

FILTER SHIPPING WEIGHT:	1,365 LBS
FILTER OPERATING WEIGHT:	17,480 LBS

ASTRAL POOL



USA

**HORIZONTAL SAND FILTER (20902)
 63"x106" WITH 8" 4 VALVE MANIFOLD**

DRAWN BY:	MM	DWG. NO:	20902-2	REV:	
SCALE: 3/8" = 1'		DATE:	10/30/02	CHECKED:	

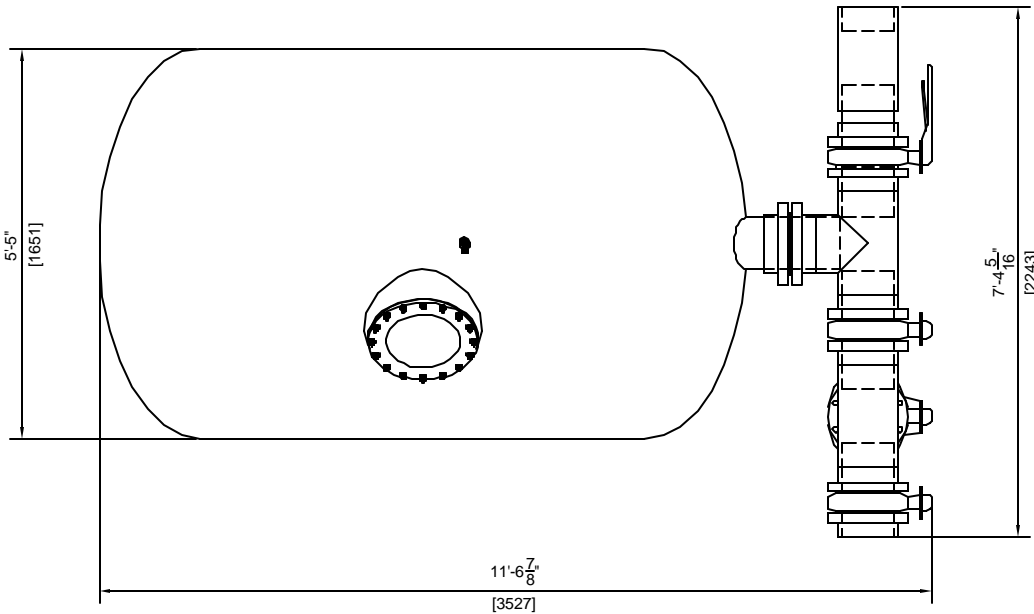
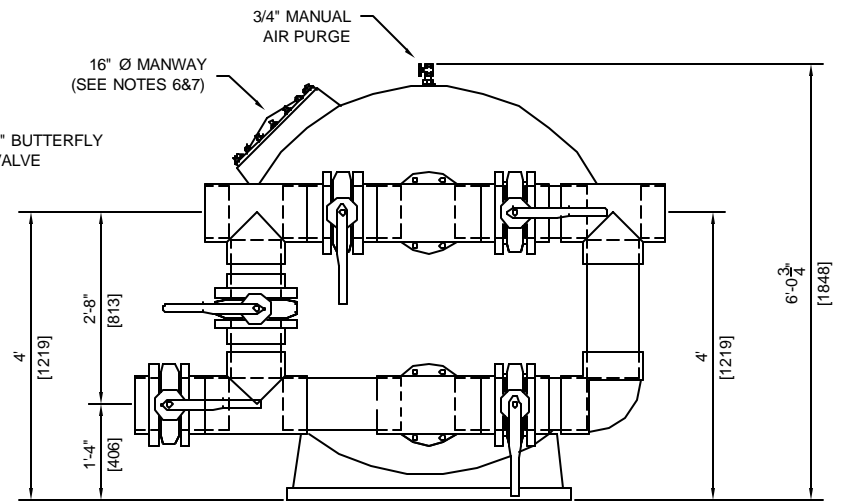
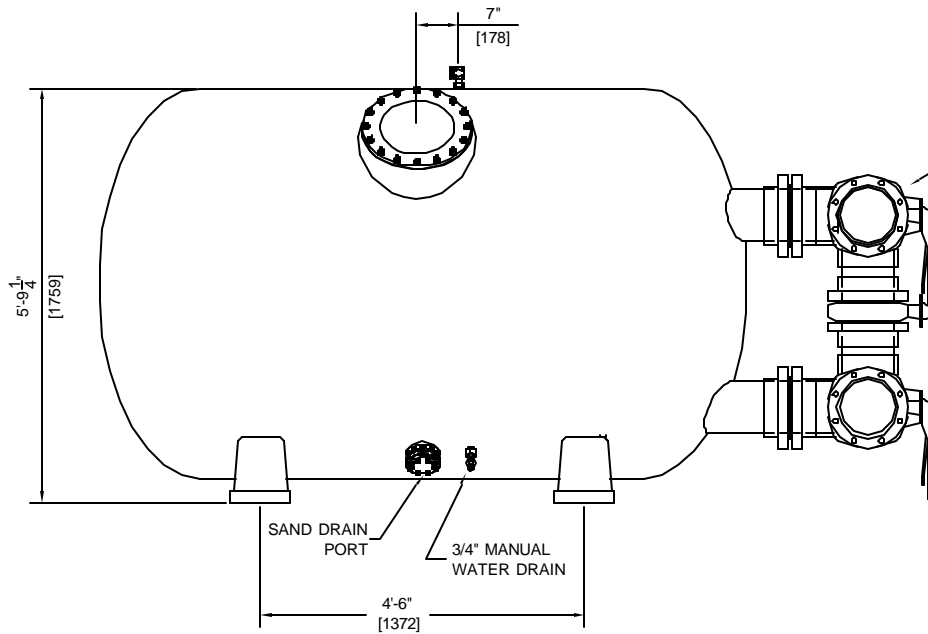

GENERAL NOTES:

1. MEDIA NOT INCLUDED WITH FILTER
2. CONCRETE SLAB TO BE DESIGNED BY OTHERS
3. FILTER MADE FROM HIGH STRENGTH FIBERGLASS AND RESINS
4. FILTERS HAVE UV STABILIZED CLEAR COAT
5. ALL INTERNAL COMPONENTS ARE CONSTRUCTED OF SCHEDULE 80 PVC.
6. MANHOLE CAN BE LOCATED ON EITHER SIDE OF FILTER. PLEASE SPECIFY AT TIME OF ORDER.
7. SAND DRAIN AND WATER DRAIN ARE PLACED ON THE SAME SIDE AS THE MANHOLE.

FILTER DATA

TOTAL SURFACE AREA:	46 SQ. FT.
MAX WORKING PRESSURE:	50 PSI.
MAX FLOW RATE:	20 GPM / SQ. FT.

MEDIA REQUIREMENTS

SAND:	5,400 LBS
GRAVEL:	3,100 LBS

WEIGHTS

FILTER SHIPPING WEIGHT:	1,365 LBS
FILTER OPERATING WEIGHT:	17,530 LBS

ASTRAL POOL



USA

**HORIZONTAL SAND FILTER (20902)
63"x106" WITH 8" 5 VALVE MANIFOLD**

DRAWN BY:	MM	DWG. NO:	20902-3	REV:	
SCALE: 3/8" = 1'		DATE:	10/30/02	CHECKED:	

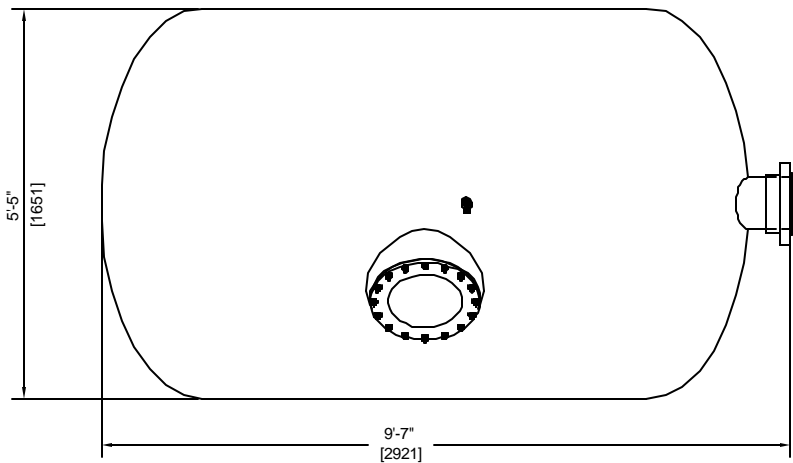
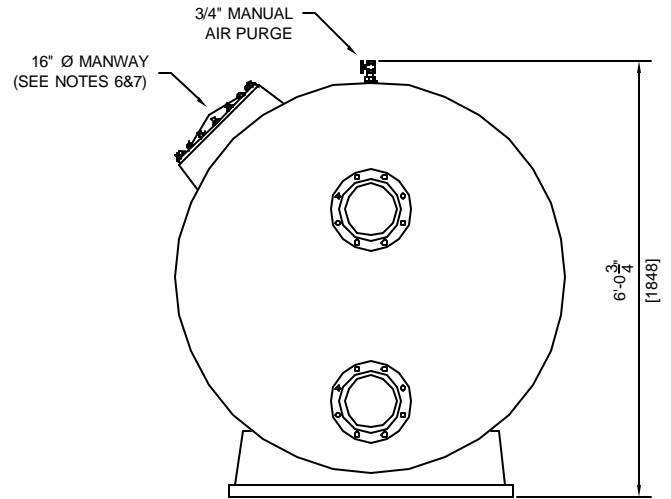
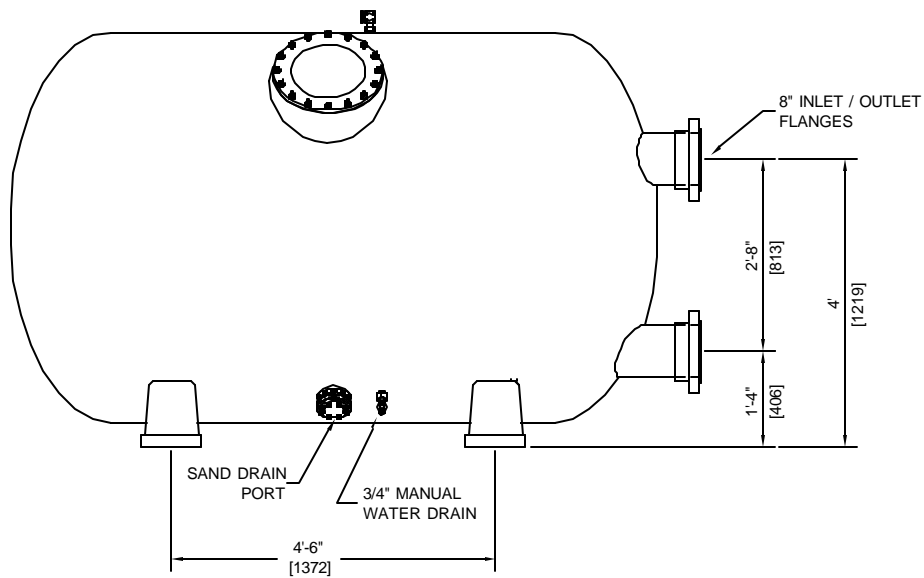

GENERAL NOTES:

1. MEDIA NOT INCLUDED WITH FILTER
2. CONCRETE SLAB TO BE DESIGNED BY OTHERS
3. FILTER MADE FROM HIGH STRENGTH FIBERGLASS AND RESINS
4. FILTERS HAVE UV STABILIZED CLEAR COAT
5. ALL INTERNAL COMPONENTS ARE CONSTRUCTED OF SCHEDULE 80 PVC
6. MANHOLE CAN BE LOCATED ON EITHER SIDE OF FILTER. PLEASE SPECIFY AT TIME OF ORDER.
7. SAND DRAIN AND WATER DRAIN ARE PLACED ON THE SAME SIDE AS THE MANHOLE.

FILTER DATA	
TOTAL SURFACE AREA:	46 SQ. FT.
MAX WORKING PRESSURE:	50 PSI.
MAX FLOW RATE:	20 GPM / SQ. FT.
MEDIA REQUIREMENTS	
SAND:	5,400 LBS
GRAVEL:	3,100 LBS
WEIGHTS	
FILTER SHIPPING WEIGHT:	1,365 LBS
FILTER OPERATING WEIGHT:	17,150 LBS

ASTRAL POOL



USA

HORIZONTAL SAND FILTER (20902)
63"x106" WITH 8" CONNECTIONS

DRAWN BY:	MM	DWG. NO:	20902	REV:
SCALE: 3/8" = 1'	DATE:	10/21/02	CHECKED:	

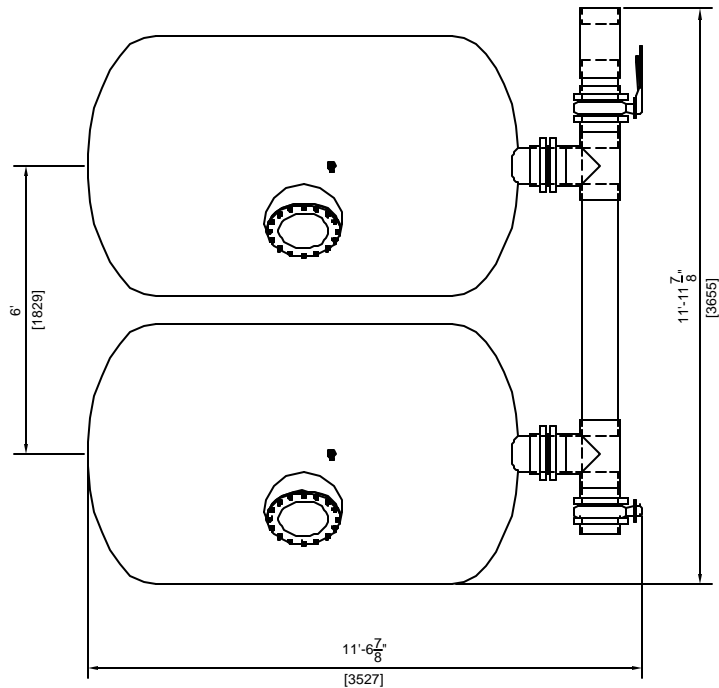
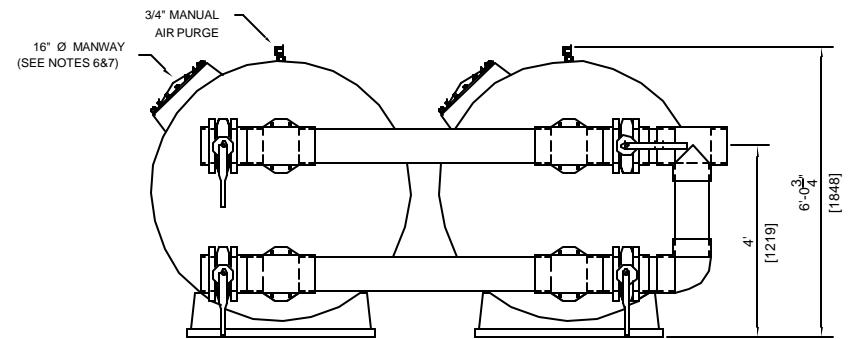
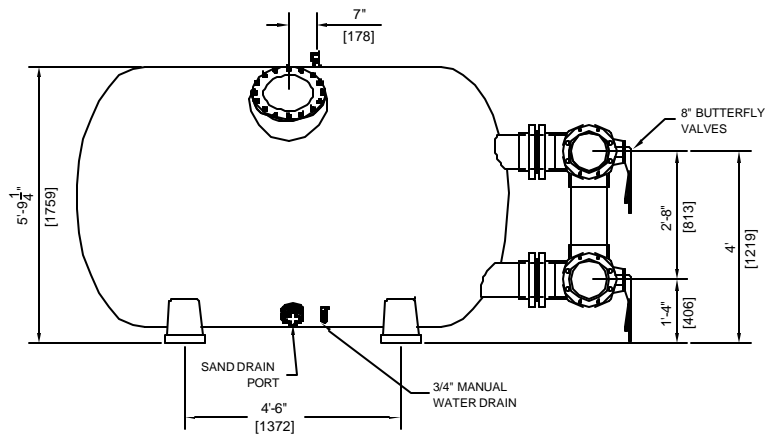

GENERAL NOTES:

1. MEDIA NOT INCLUDED WITH FILTER
2. CONCRETE SLAB TO BE DESIGNED BY OTHERS
3. FILTER MADE FROM HIGH STRENGTH FIBERGLASS AND RESIN
4. FILTERS HAVE UV STABILIZED CLEAR COAT
5. ALL INTERNAL COMPONENTS ARE CONSTRUCTED OF SCHEDULE 80 PVC.
6. MANHOLE CAN BE LOCATED ON EITHER SIDE OF FILTER. PLEASE SPECIFY AT TIME OF ORDER.
7. SAND DRAIN AND WATER DRAIN ARE PLACED ON THE SAME SIDE AS THE MANHOLE.

FILTER DATA

TOTAL SURFACE AREA:	92 SQ. FT.
MAX WORKING PRESSURE:	50 PSI.
MAX FLOW RATE:	20 GPM / SQ. FT.

MEDIA REQUIREMENTS

SAND:	5,400 LBS EA
GRAVEL:	3,100 LBS EA

WEIGHTS

FILTER SHIPPING WEIGHT	1,365 LBS EA
FILTER OPERATING WEIGHT:	34,900 LBS



**DUAL HORIZONTAL FILTER (20902)
63"x106" W/ 8" 4 VALVE MANIFOLD**

DRAWN BY: MM	DWG. NO: 20902-5	REV:
SCALE: 1/4" = 1'	DATE: 10/30/02	CHECKED:

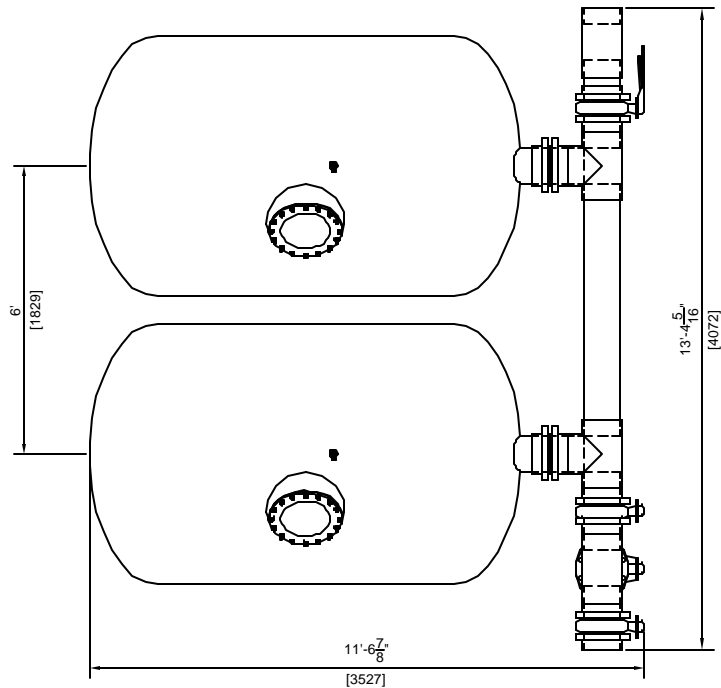
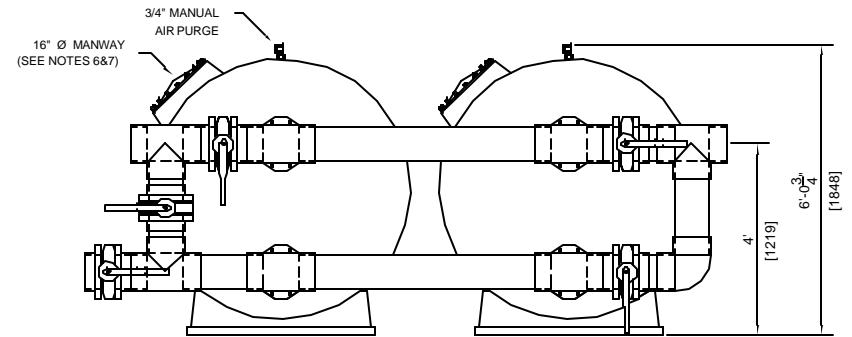
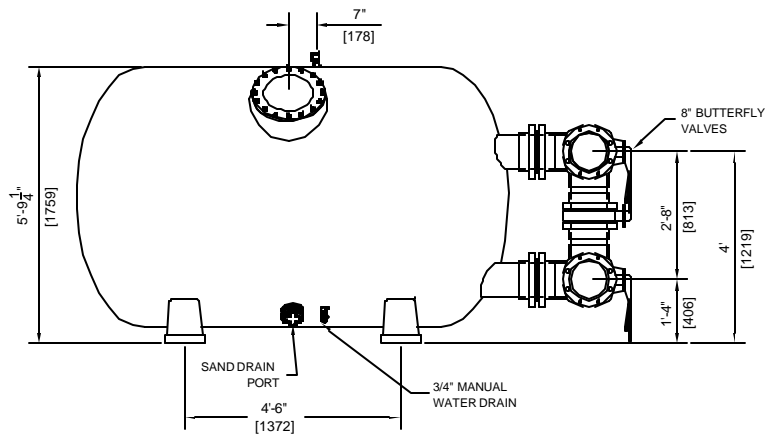

GENERAL NOTES:

1. MEDIA NOT INCLUDED WITH FILTER
2. CONCRETE SLAB TO BE DESIGNED BY OTHERS
3. FILTER MADE FROM HIGH STRENGTH FIBERGLASS AND RESIN
4. FILTERS HAVE UV STABILIZED CLEAR COAT
5. ALL INTERNAL COMPONENTS ARE CONSTRUCTED OF SCHEDULE 80 PVC.
6. MANHOLE CAN BE LOCATED ON EITHER SIDE OF FILTER. PLEASE SPECIFY AT TIME OF ORDER.
7. SAND DRAIN AND WATER DRAIN ARE PLACED ON THE SAME SIDE AS THE MANHOLE.

FILTER DATA

TOTAL SURFACE AREA:	92 SQ. FT.
MAX WORKING PRESSURE:	50 PSI.
MAX FLOW RATE:	20 GPM / SQ. FT.

MEDIA REQUIREMENTS

SAND:	5,400 LBS EA
GRAVEL:	3,100 LBS EA

WEIGHTS

FILTER SHIPPING WEIGHT	1,365 LBS EA
FILTER OPERATING WEIGHT:	34,900 LBS



DUAL HORIZONTAL FILTER (20902)
63"x106" W/ 8" 5 VALVE MANIFOLD

DRAWN BY: MM	DWG. NO: 20902-6	REV:
SCALE: 1/4" = 1'	DATE: 10/30/02	CHECKED: