

Wood Deck Anchor Instructions



PART #: F-40220-AT1

Pro Pool Lift - Weight Capacity (450 LBS) / Max Setback (19")
Pro Pool Lift Ext Base 23"- Weight Capacity (450 LBS) / Max Setback (23")
Pro Pool Lift Ext Base 26"- Weight Capacity (450 LBS) / Max Setback (26")
Pro Pool Lift Deep Draft - Weight Capacity (400 LBS) / Max Setback (17")
Ranger Lift - Weight Capacity (350 LBS) / Max Setback (19")
Pathfinder Lift - Weight Capacity (300 LBS) / Max Setback (16")

MANDATORY – LEAVE THIS MANUAL WITH LIFT OWNER



Read & follow all instructions
Lift safety can only be ensured if the lift is installed
and operated according to these instructions



NEVER permit children to play on or around the lift
Do not allow children to use the lift without adult supervision



NEVER apply direct water pressure to the electronics



NEVER use the lift with a dry pool



For safety reasons, **NEVER** swim alone



ADA-Compliant Instructions

The AT-SERIES WOOD-DECK ANCHOR has been designed to comply with the latest ADA requirements. It has a simple design, and can be retrofitted with a nominal amount of time, tools and expense. To be ADA compliant, the fixed lift must have the required clear-deck space as shown below. The AT-SERIES WOOD-DECK ANCHOR is designed to remain in place if the lift is removed for storage.

Note: the AT-SERIES WOOD-DECK ANCHOR has been designed to comply with the NEC requirements for bonding. By bonding the anchor you are also bonding the installed lift. Bond the lift according to your local requirements (ref NEC).

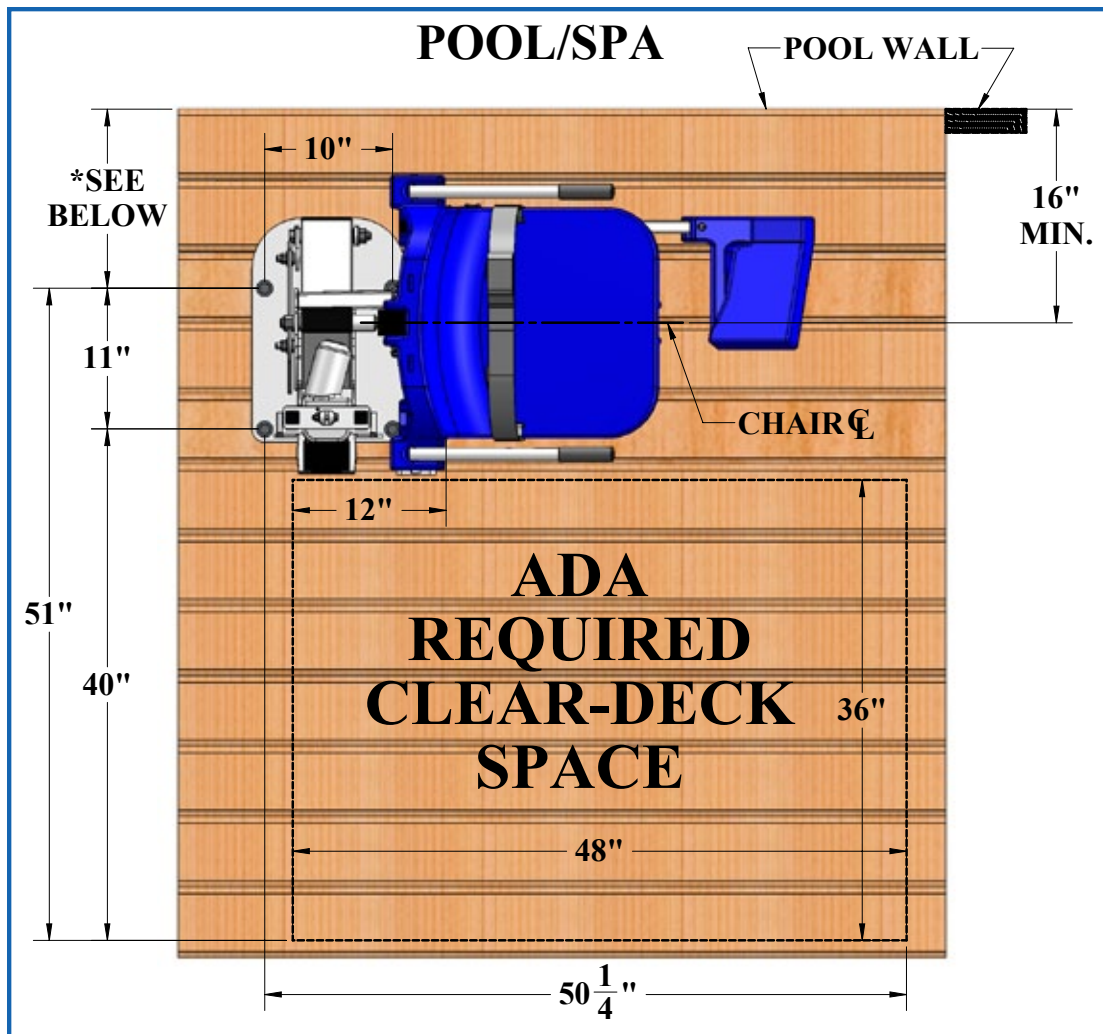

Front Anchor Setback Distance

Pathfinder: 14.5"-16"	Ranger: 14.5"-19"
Pro Pool: 14.5"-19"	Pro Pool 23" Ext Base: 19"-23"
Pro Pool 26" Ext Base: 23"-26"	Pro Pool Deep Draft: 14.5"-17"

Note: All setback distances are based on a straight pool wall. Setback distances will change for curved pool walls. Contact Aqua Creek for curved wall setback distances.

The AT-Series Wood-Deck Anchor

The diagram below shows the AT-SERIES WOOD-DECK ANCHOR with the included bonding-lug and hardware. Note the bonding-lug can be attached to either the front or back of the AT-SERIES WOOD-DECK ANCHOR, and on either the top or bottom for ease of wiring.

NOTE: the AT-SERIES WOOD-DECK ANCHOR should be electrically bonded to the pool/spa bonding grid using minimum 8AWG solid copper wire. Attaching the 8AWG solid copper wire to the copper bonding lug and to the bonding grid will bond the installed lift through the 1/2" mounting bolts.

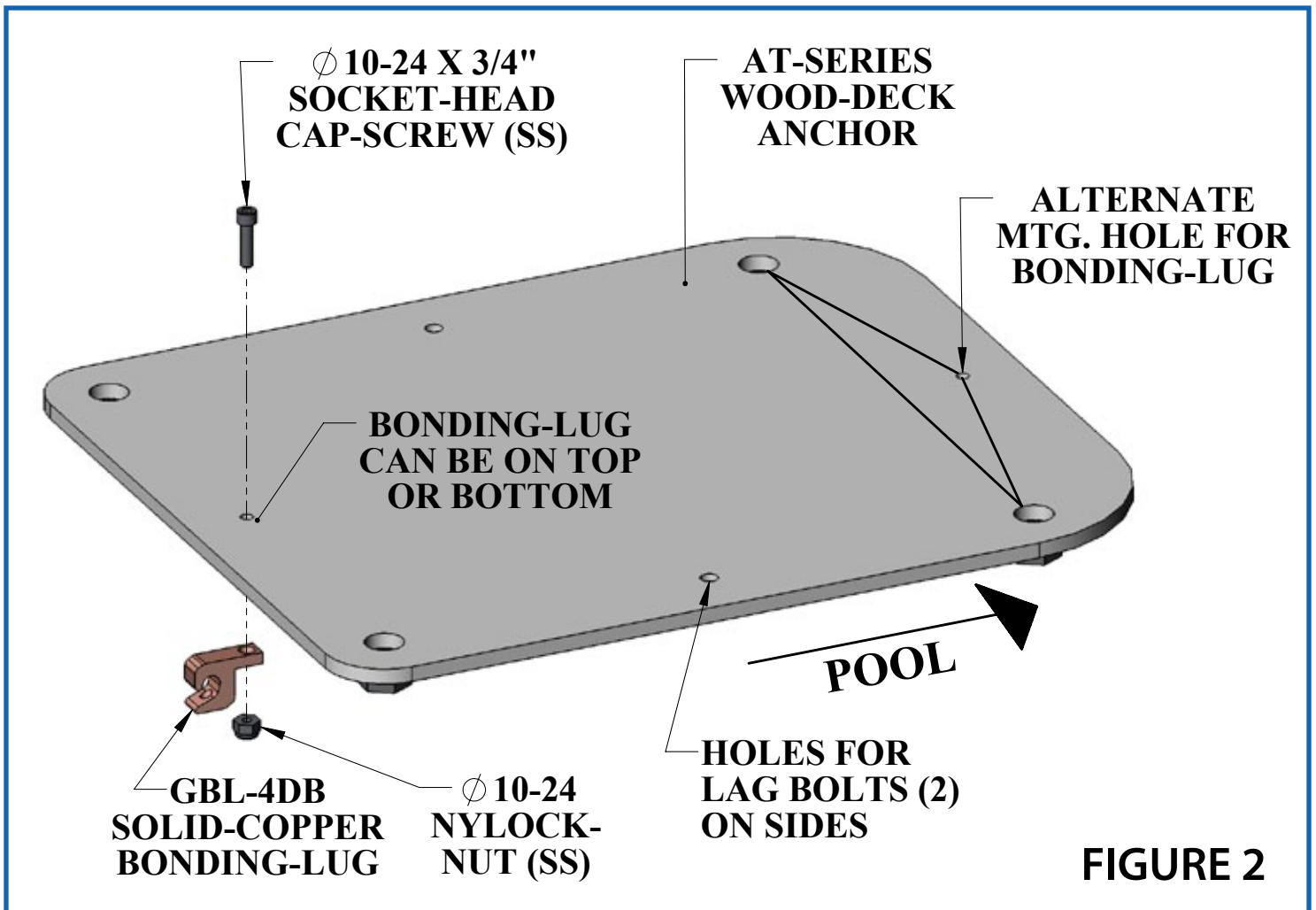

Installation Overview: Components

The following diagram shows the AT-SERIES WOOD-DECK ANCHOR in a typical installation. Note the 2" x 6" x 36" reinforcing boards are installed first, under the decking, to support the entire area around the lift. The following tools and hardware will be required to complete the installation.

TOOLS REQUIRED:

- 1] 5/8" DRILL BIT
- 2] CORDLESS OR ELECTRIC DRILL
- 3] MARKING PEN

STAINLESS HARDWARE REQUIRED:

- 1] 1/4" X 2" LAG BOLTS (2)
- 2] 1/4" FLAT WASHERS (2)
- 3] 1/2"-13 X 4" HEX BOLTS (4)
- 4] 1/2" FLAT WASHERS (4)

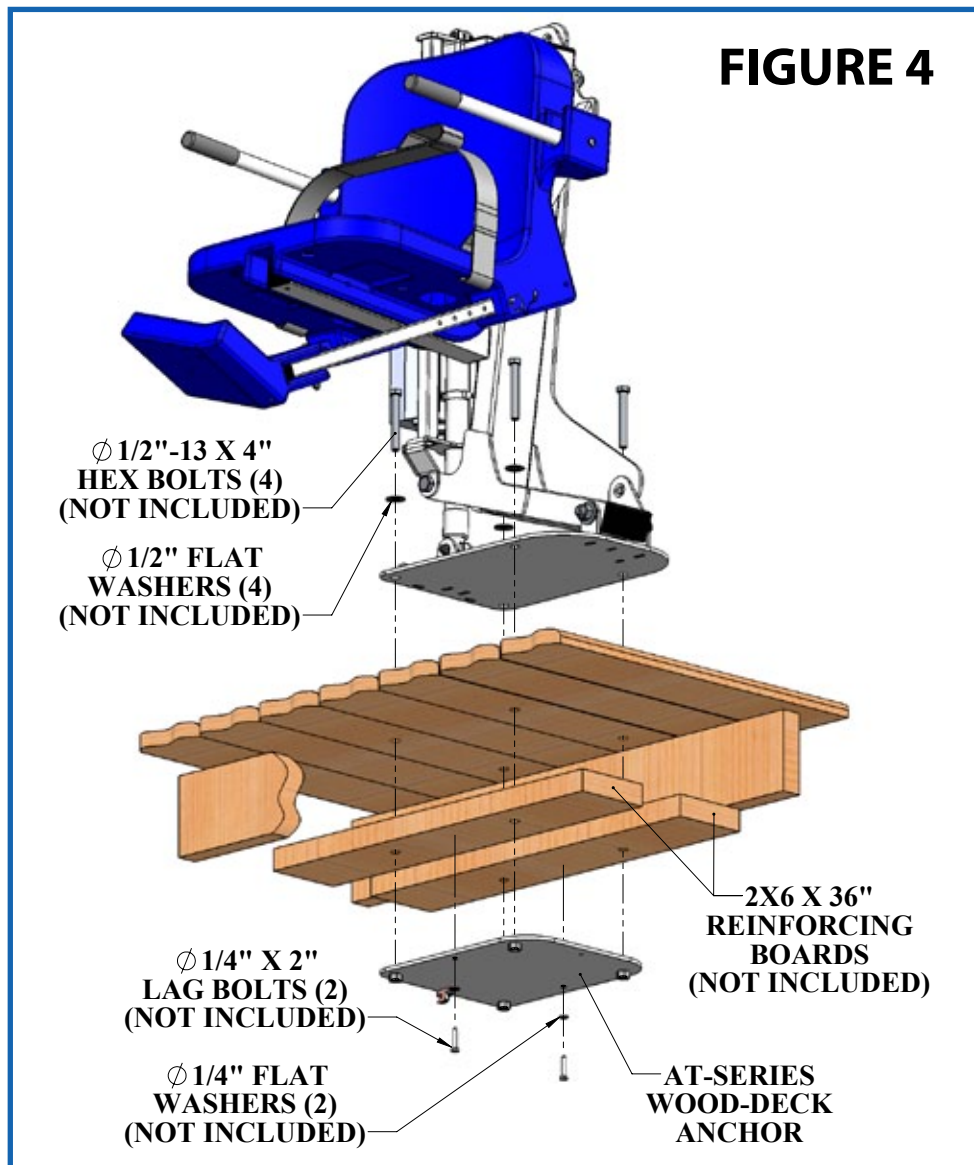

NOTE:

Bolt length shown is for **typical 2"** thick deck boards
Longer bolts may be necessary for your application
We recommend 316 stainless hardware

Step 1: Install 2x6 Reinforcing Boards

Once the location for the lift has been determined it will be necessary to install two (2) 2" x 6" x 36" long reinforcing boards underneath the location of the anchor. The AT-SERIES WOOD-DECK ANCHOR will be mounted between two floor joists, and the joists can run either towards the pool/spa or side-to-side. The following instructions show the joists running towards the pool/spa, for illustration purposes.



REINFORCING BOARDS: INSTALL AGAINST FLOOR JOISTS AND FRONT PLATE
(BOTTOM VIEW)

NOTE:

The reinforcing boards are installed from underneath, flush against the floor joists on either side, and all the way up to the front plate/hanger. Use deck screws to hold the reinforcing boards in place.

Step 2: Mark Location For 5/8" Holes

Using the lift's baseplate as a template, mark the four holes at the desired lift location (Reference chart on page 2). Also, make sure to line the holes between the floor joists so the AT-SERIES WOOD-DECK ANCHOR fits between the joists.



PLACE THE BASEPLATE AT DESIRED LOCATION



MARK THE FOUR MOUNTING HOLES

Step 3: Drill Four (4) 5/8" Diameter Holes

With the hole locations marked, drill the four mounting holes. Using a 5/8" drill bit and an electric or cordless drill, drill straight down at the four marked locations. Use a square or level to make sure you are drilling straight down, and make sure you drill at the exact center of the circles.

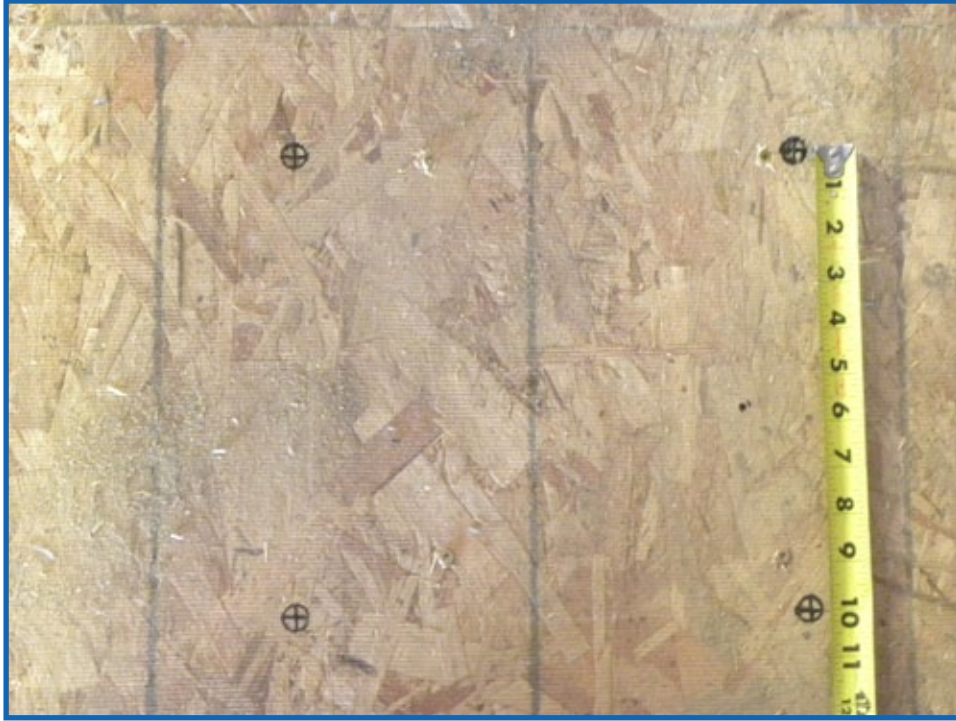

HINT: USE A TAPE-MEASURE TO CHECK THE HOLES ARE 11" x 10" SQUARE



WITH 5/8" BIT: DRILL STRAIGHT-DOWN AT 4 MARKED LOCATIONS

Step 4: Install The Wood-Deck Anchor

With the four mounting holes drilled the AT-SERIES WOOD-DECK ANCHOR can now be installed underneath the deck and onto the reinforcing boards. Use the mounting bolts (1/2" hex) to hold the anchor in place, and install the 1/4" lag bolts as shown below. When the anchor is in place the 1/2" hex bolts can be removed and the lift can be installed. Also, bond the lift using the copper bonding lug per local electrical codes.

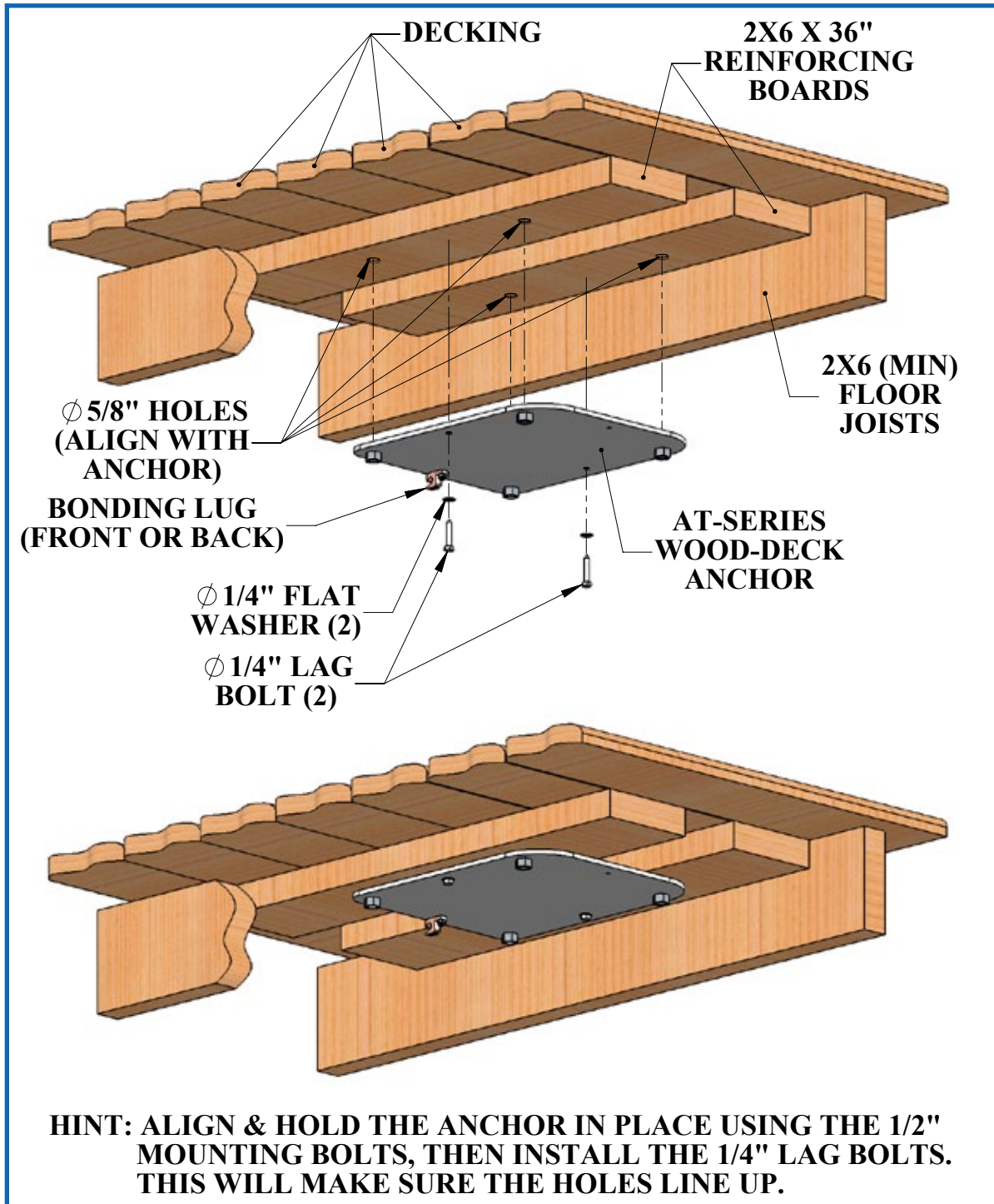

Step 5: Install The AT-Series Lift

Once the AT-SERIES WOOD-DECK ANCHOR has been installed the lift is now ready for installation. Using the 1/2" mounting bolts and flat washers, mount the lift to the deck as shown below. Use a 9/16" wrench or socket and tighten the bolts until snug.

DO NOT OVERTIGHTEN THE MOUNTING BOLTS!

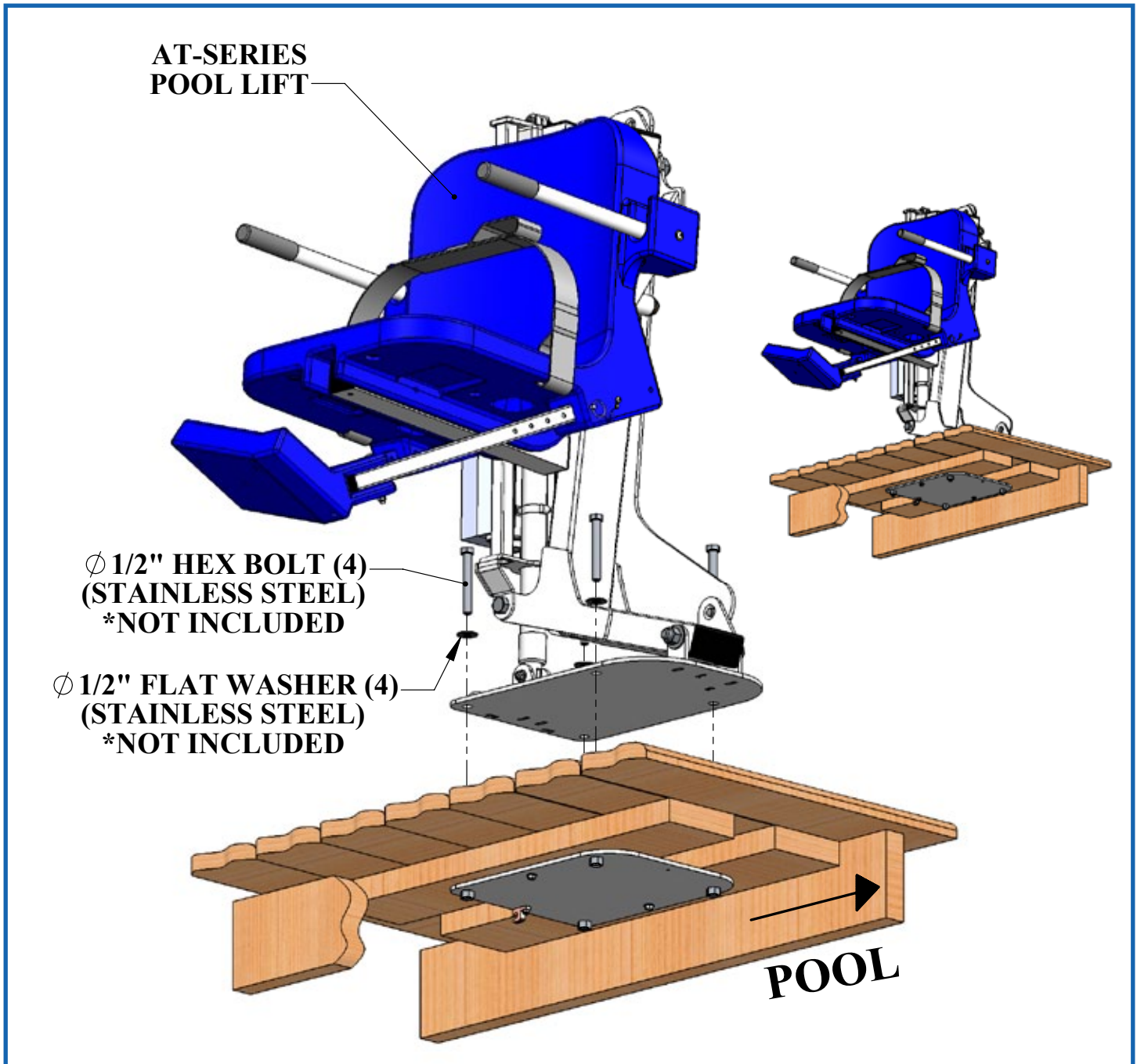

**Length of mounting bolts will depend on thickness of deck you need to go through.*