

# 9" SQUARE WAVE ANTI-ENTRAPMENT SUCTION OUTLET COVER, VENTED RISER RING AND MUD FRAME



**VGB CERTIFIED  
SPECIFICATIONS**

**Floor Flow Rating**  
224 GPM at 1.5 fps

**Wall Flow Rating**  
224 GPM at 1.5 fps

**Sump Depth**  
3" minimum

**Open Area**  
48.4 in<sup>2</sup>

## FEATURES

All components meet or exceed ANSI/APSP 16-2011 and NSF/ANSI 50-2009a national standards and ASTM G154 UV testing exposure

Easily and safely retrofits to 9" square 3/4" deep frames

Manufactured from superior UV-resistant engineered polymers

#316 stainless steel screws

Trademarked VGB compliance button easily identifies VGB 2008 compliant cover from on deck and underwater

Online product support including downloadable CAD files, General Certificate of Conformity, third-party certificate, installation instructions and more

Replace drain cover every five years from the date of installation

See next page for additional product configurations

8 per case

U.S. patents D623727 and D663388

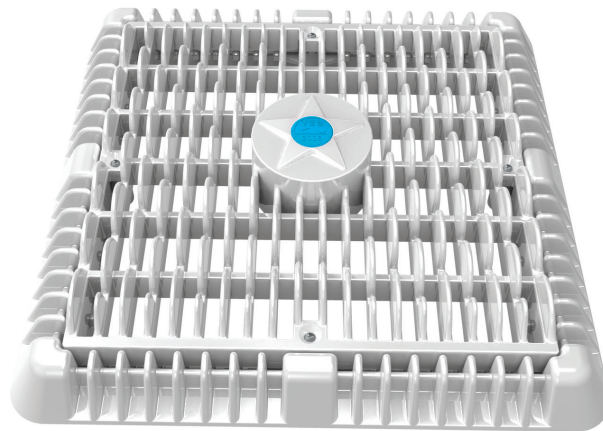

Part # WAV9WRxxx

Fits: AquaStar 9" standard models and American (Pentair) with 3/4" deep existing frames and four screw hole pattern.

## STANDARD COLORS

- WAV9WR101 – White
- WAV9WR102 – Black
- WAV9WR103 – Light Gray
- WAV9WR104 – Blue
- WAV9WR105 – Dark Gray
- WAV9WR108 – Tan

Replaces p/n 9xxx, P9xxx, SRF59xxx, SUN9xxx, SUN9WRxxx, WAV9xxx, 9MFxxx

**VGB 2008 Compliant**

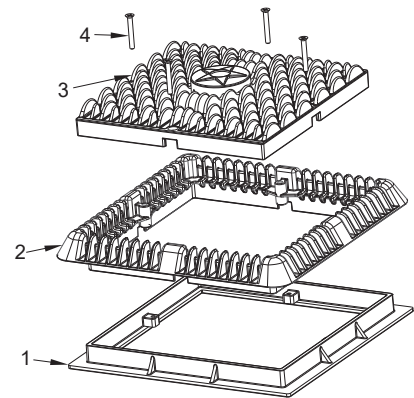
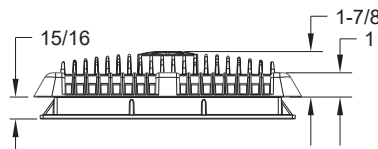
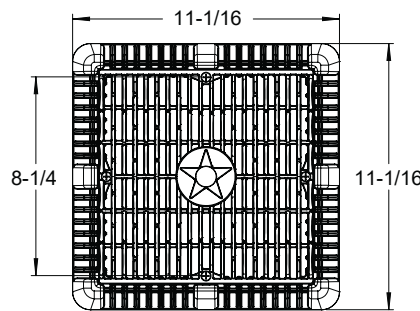

1. 9" Square Mud Frame
2. 9" Square Riser Ring
3. 9" Square "Wave" Suction Outlet Cover
4. 10 x 1-3/4" Flat Head Phillips, 316 SS, Qty 4

P 877-768-2717 F 877-276-POOL Outside the US: P +1-949-336-1940 F +1-949-336-1940

info@aquastarpoolproducts.com www.aquastarpoolproducts.com

# 9" SQUARE WAVE ANTI-ENTRAPMENT SUCTION OUTLET COVER WITH 3" SOCKET SUMP



**VGB CERTIFIED  
SPECIFICATIONS**

**Floor Flow Rating**  
224 GPM at 1.5 fps

**Wall Flow Rating**  
224 GPM at 1.5 fps

**Sump Depth**  
*Use sump included*

**Open Area**  
48.4 in<sup>2</sup>

## FEATURES

All components meet or exceed ANSI/APSP 16-2011 and NSF/ANSI 50-2009a national standards and ASTM G154 UV testing exposure

Sump manufactured from strong PVC sump with 3" socket and 4" spigot side port, and 2" socket 2½" spigot bottom port

Manufactured from superior UV-resistant engineered polymers

Comes with 3" and 2" NPT cap with o-ring for pressure testing and winterizing

#316 stainless steel screws

Trademarked VGB compliance button easily identifies VGB 2008 compliant cover from on deck and underwater

Online product support including downloadable CAD files, General Certificate of Conformity, third-party certificate, installation instructions and more

Replace drain cover every five years from the date of installation

1 per case

**NEW** Hassle-free pressure testing and winterizing



*Optional 2" hydrostatic relief valve available p/n SK43101*

**Hassle-free  
pressure testing and winterizing**  
Comes with a 3" and 2" NPT cap with O-ring. *No knock-outs required.*

Part # WAV9WRxxxSSB

## STANDARD COLORS

- WAV9WR101SSB – White
- WAV9WR102SSB – Black
- WAV9WR103SSB – Light Gray
- WAV9WR104SSB – Blue
- WAV9WR105SSB – Dark Gray
- WAV9WR108SSB – Tan

**VGB 2008 Compliant**

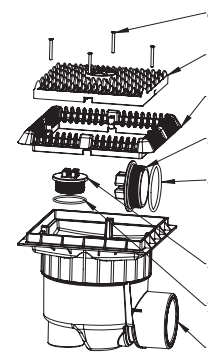
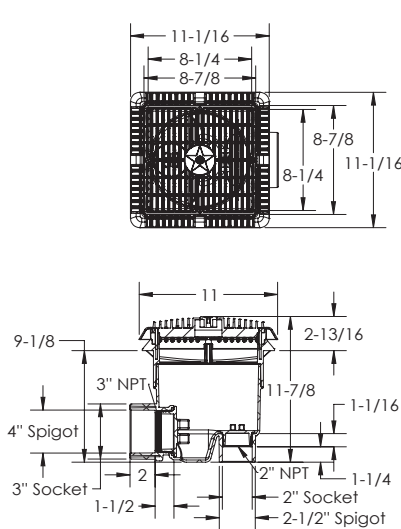

1. Side Port Sump Bucket, 9" Square Frame
2. 2" Plug O-Ring
3. 2" NPT Plug
4. 3" Plug O-Ring
5. 3" NPT Plug
6. 9" Square Riser Ring
7. 9" Square "Wave" Suction Outlet Cover
8. 10 x 13/4" Flat Head Phillips, 316 SS, Qty 4

P 877-768-2717 F 877-276-POOL Outside the US: P +1-949-336-1940 F +1-949-336-1940  
 info@aquastarpoolproducts.com www.aquastarpoolproducts.com

# 9" SQUARE WAVE ANTI-ENTRAPMENT SUCTION OUTLET COVER WITH 6" SOCKET DEEP PVC SUMP



**VGB CERTIFIED  
SPECIFICATIONS**

**Floor Flow Rating**  
224 GPM at 1.5 fps

**Wall Flow Rating**  
224 GPM at 1.5 fps

**Sump Depth**  
3" minimum

**Open Area**  
48.4 in<sup>2</sup>

## FEATURES

All components meet or exceed ANSI/APSP 16-2011 and NSF/ANSI 50-2009a national standards and ASTM G154 UV testing exposure

Manufactured from superior UV-resistant engineered polymers

No transitional glue required

Comes with 6" tapered threaded pipe plug for easy pressure testing and winterization

#316 stainless steel screws

Online product support including downloadable CAD files, General Certificate of Conformity, third-party certificate, installation instructions and more

Replace drain cover every five years from the date of installation  
1 per case



Part # WAV9WRxxxF

## STANDARD COLORS

- WAV9WR101F – White
- WAV9WR102F – Black
- WAV9WR103F – Light Gray
- WAV9WR104F – Blue
- WAV9WR105F – Dark Gray
- WAV9WR108F – Tan

VGB 2008 Compliant

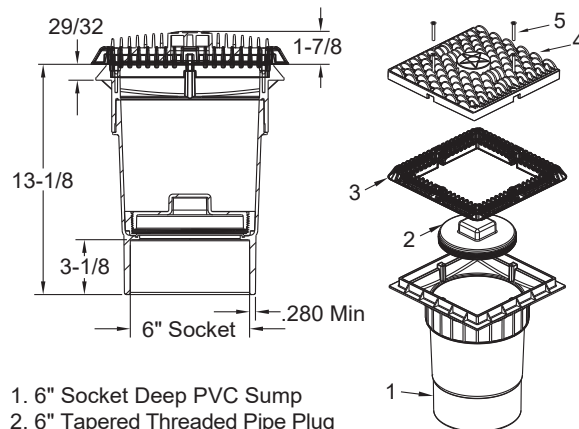

1. 6" Socket Deep PVC Sump
2. 6" Tapered Threaded Pipe Plug
3. 9" Square Vented Riser Ring
4. 9" Square "Wave" Suction Outlet Cover
5. 10 x 1-3/4" Flat Head Phillips, 316 SS, Qty 4

P 877-768-2717 F 877-276-POOL Outside the US: P +1-949-336-1940 F +1-949-336-1940  
info@aquastarpoolproducts.com www.aquastarpoolproducts.com