

# 9" SQUARE WAVE ANTI-ENTRAPMENT SUCTION OUTLET COVER WITH 6" SOCKET DEEP PVC SUMP



**VGB CERTIFIED  
SPECIFICATIONS**

**Floor Flow Rating**  
224 GPM at 1.5 fps

**Wall Flow Rating**  
224 GPM at 1.5 fps

**Sump Depth**  
3" minimum

**Open Area**  
48.4 in<sup>2</sup>

## FEATURES

All components meet or exceed ANSI/APSP 16-2011 and NSF/ANSI 50-2009a national standards and ASTM G154 UV testing exposure

Manufactured from superior UV-resistant engineered polymers

No transitional glue required

Comes with 6" tapered threaded pipe plug for easy pressure testing and winterization

#316 stainless steel screws

Online product support including downloadable CAD files, General Certificate of Conformity, third-party certificate, installation instructions and more

Replace drain cover every five years from the date of installation  
1 per case



Part # WAV9WRxxxF

## STANDARD COLORS

- WAV9WR101F – White
- WAV9WR102F – Black
- WAV9WR103F – Light Gray
- WAV9WR104F – Blue
- WAV9WR105F – Dark Gray
- WAV9WR108F – Tan

VGB 2008 Compliant

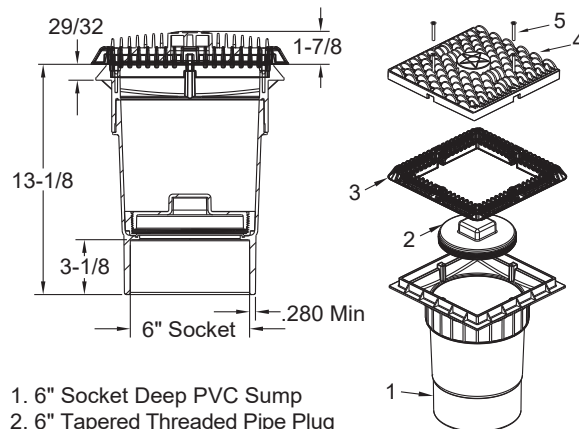

1. 6" Socket Deep PVC Sump
2. 6" Tapered Threaded Pipe Plug
3. 9" Square Vented Riser Ring
4. 9" Square "Wave" Suction Outlet Cover
5. 10 x 1-3/4" Flat Head Phillips, 316 SS, Qty 4

P 877-768-2717 F 877-276-POOL Outside the US: P +1-949-336-1940 F +1-949-336-1940  
info@aquastarpoolproducts.com www.aquastarpoolproducts.com